

PRODUCT SPECIFICATION DRAWING

HOLDRITE® Rapid Clamp™ #251

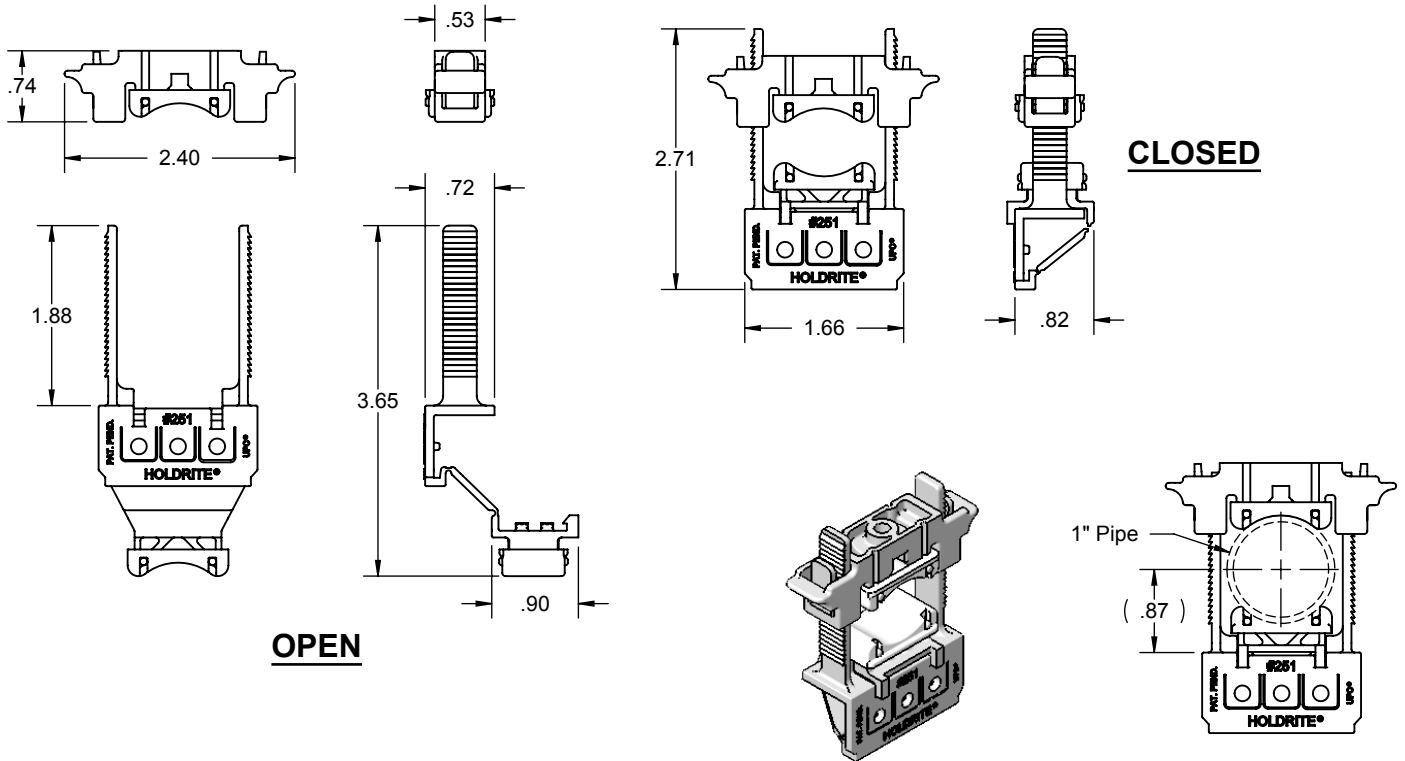

The HOLDRITE® Rapid Clamp™ #251 is a variable closure tube clamp designed to attach securely to the HOLDRITE #170 Bracket without the use of screws. Clamp supports up to 1"CTS tube size and is compatible with any tubing including Copper, PEX, CPVC tubing, and conduit. The #251 Rapid Clamp is UPC listed.

Product Information:

- Material:
 Top & Bottom Clamp: Polypropylene, FR UL94-HB, Gray
 Pads: TPR, natural (off-white), 50 shore A
- Temperature range: -10 °F to +140 °F (suspension)
 -10 °F to +180 °F (top mount)
- Load rating: 25 lbs in suspended mode, 200 lbs maximum in top mount
- IAPMO listed, per standard PS42-96
- Patent Pending



THIS INFORMATION IS PROPRIETARY TO HUBBARD ENTERPRISES AND IS SUBJECT TO CHANGE WITHOUT NOTICE. ANY REPRODUCTION IN PART OR WHOLE WITHOUT THE WRITTEN PERMISSION OF HUBBARD ENTERPRISES IS PROHIBITED.



Product Submittal	
Job Name:	
Date:	
Part Number:	Qty:
Architect / Owner:	
Contractor:	
Notes:	