

PRODUCT SPECIFICATION DRAWING

LOCKRITE™ #609-N-6 Bracket

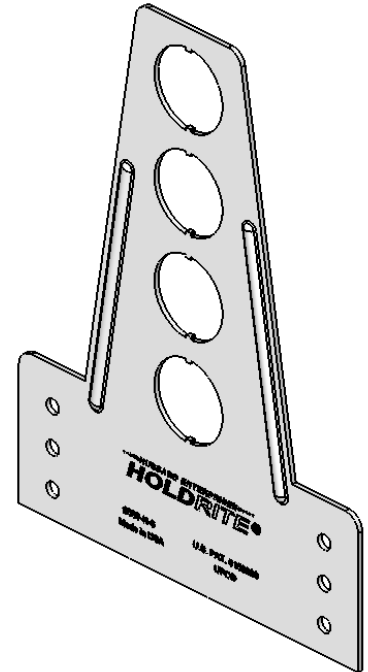
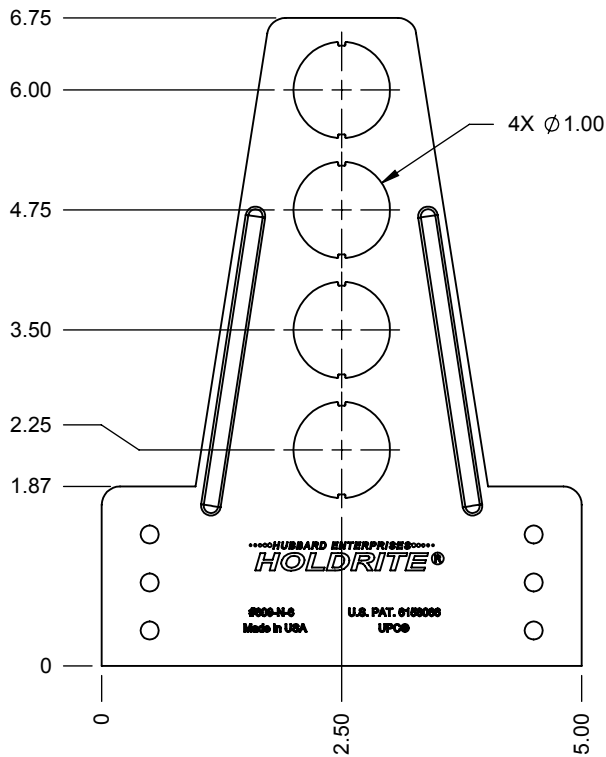

ALL DIMENSIONS IN INCHES

The LOCKRITE™ #609-N-6 is a 16 gage galvanized steel bracket with 1" hole on 1-1/4" centers. Ideal for toilets or hose bib stub-outs. Also serves as a nail plate. This bracket is designed to work exclusively with our glueable HOLDRITE® #604 (1/2") or #605 (3/4") inserts when installing CPVC tubing. Inserts snaps into bracket.

Product Information:

- Material: 16 gage CRS, galvanized
- Load rating: 25 pounds
- UPC / IPC / IAPMO listed

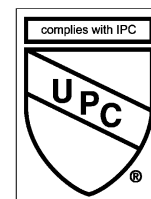

THIS INFORMATION IS PROPRIETARY TO HUBBARD ENTERPRISES AND IS SUBJECT TO CHANGE WITHOUT NOTICE. ANY REPRODUCTION IN PART OR WHOLE WITHOUT THE WRITTEN PERMISSION OF HUBBARD ENTERPRISES IS PROHIBITED.

.....HUBBARD ENTERPRISES.....
HOLDRITE®
 "Converting Makeshift Methods into Engineered Solutions"

Product Submittal	
Job Name:	
Date:	
Part Number:	Qty:
Architect / Owner:	
Contractor:	
Notes:	