

PRODUCT SPECIFICATION DRAWING

QUICKSTAND™ 21-1/2" X 21-1/2" (Water Heater & Equipment Support)

#40-S-22-A (assembled) and #40-S-22-U (unassembled)

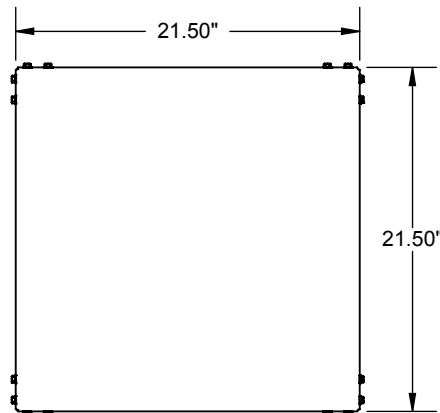
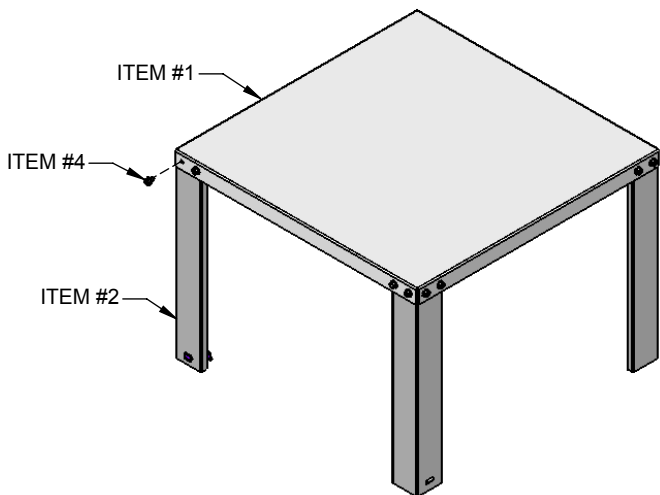

ALL DIMENSIONS IN INCHES

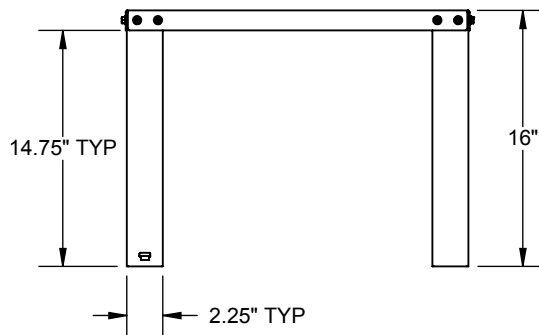

The QUICKSTAND™ #40-S-22- (A or U) stands safely elevates water heaters and other equipment above the floor (900 lbs rating).

Product Information:

- Material:
 - Item #1: Top, 14 gage CRS, galvanized
 - Item #2: Leg, 16 gage CRS, galvanized, 4 places
 - Item #3: Safety Clip, 14 gage CRS, galvanized, 2 places
 - Item #4: Screw, PH, Sems, #1/4 X 1/2"L (w / external starwasher), 16 places
 - Item #5: Lag Bolt, #1/4 X 2-1/2"L, self-drilling, 2 places (items #3 and #5 included with product)
- Engineered and lab tested to meet Uniform Plumbing Code (UPC) and International Plumbing Code (IPC) requirements, including elevation of water heater's ignition source 18" above the floor
- Holds up to 900 pounds capacity (up to 65 gallon tank)
- QUICKSTAND™ weight 17-1/2 pounds without packaging
- Available in assembled and unassembled configurations



THIS INFORMATION IS PROPRIETARY TO HUBBARD ENTERPRISES AND IS SUBJECT TO CHANGE WITHOUT NOTICE. ANY REPRODUCTION IN PART OR WHOLE WITHOUT THE WRITTEN PERMISSION OF HUBBARD ENTERPRISES IS PROHIBITED.

.....HUBBARD ENTERPRISES.....
HOLDRITE®
 "Converting Makeshift Methods into Engineered Solutions"

Product Submittal	
Job Name:	
Date:	
Part Number:	Qty:
Architect / Owner:	
Contractor:	
Notes:	