

PRODUCT SPECIFICATION DRAWING

HOLDRITE® #Strut Clamp™ #257-P

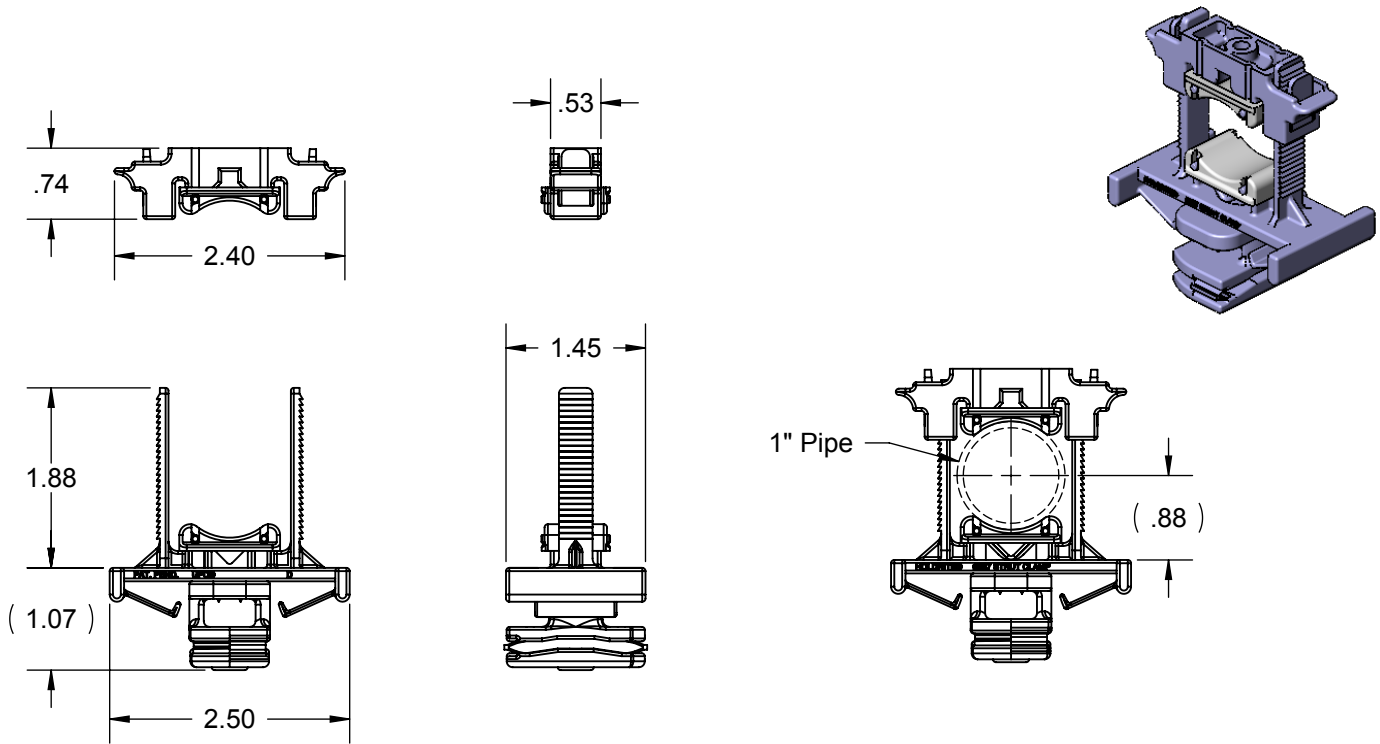

ALL DIMENSIONS IN INCHES

The HOLDRITE® Acoustical Strut Clamp™ #257-P is a strong, sound rated variable closure clamp. Two acoustical inserts isolate the pipe from the support structure, reducing piping noise and vibration, while allowing normal pipe expansion and contraction. Clamp supports up to 1" CTS tubing sizes. Supports Copper, PEX, CPVC tubing, conduit, etc. Framework complies with UL94V-2 fire rating.

Product Information:

- Material:
Top & Bottom Clamp: Nylon, medium blue, FR UL94V-2
Pads: TPR, natural (off-white), 50 shore A
- Temperature range: -10°F to +180°F
- Load rating: 25 lbs in suspended mode, 200 lbs maximum in top mount
- UPC / IPC / IAPMO listed

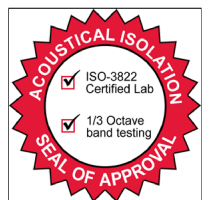
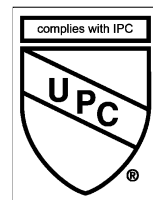

THIS INFORMATION IS PROPRIETARY TO HUBBARD ENTERPRISES AND IS SUBJECT TO CHANGE WITHOUT NOTICE. ANY REPRODUCTION IN PART OR WHOLE WITHOUT THE WRITTEN PERMISSION OF HUBBARD ENTERPRISES IS PROHIBITED.

.....HUBBARD ENTERPRISES.....
HOLDRITE®
 "Converting Makeshift Methods into Engineered Solutions"

Product Submittal	
Job Name:	
Date:	
Part Number:	Qty:
Architect / Owner:	
Contractor:	
Notes:	