

# PRODUCT SPECIFICATION DRAWING

## QUICK BELT™ #QB-50-F

### Seismic support for water heaters

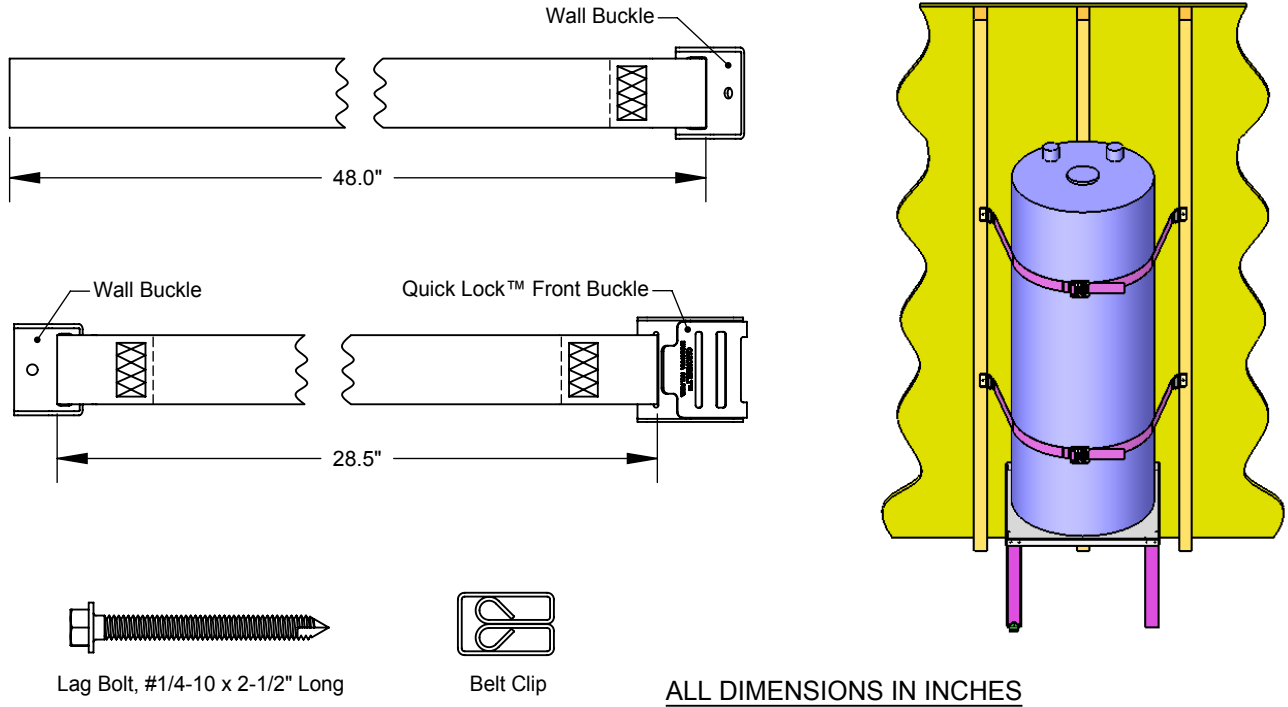

The QUICK BELT™ #QB-50-F is a seismic/earthquake support system for water heaters up to 80 gallons in size. The system includes: (4) Straps, (4) Lag Bolts and (2) Belt Clips. The Quick Lock™ system allows for secure locking of the strap from the front side of the water heater.

#### Product Information:

- Material:  
 Wall Buckles: 12 gage CRS, galvanized  
 Front Buckle: 14 gage CRS, galvanized  
 Strap: Polyester, medium gray
- Approval: DSA #002-04
- UPC / IPC / IAPMO listed

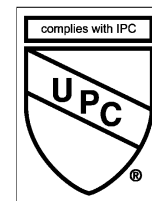
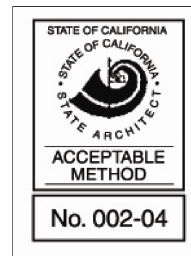

Product Submittal	
Job Name:	
Date:	
Part Number:	Qty:
Architect / Owner:	
Contractor:	
Notes:	

THIS INFORMATION IS PROPRIETARY TO HUBBARD ENTERPRISES AND IS SUBJECT TO CHANGE WITHOUT NOTICE. ANY REPRODUCTION IN PART OR WHOLE WITHOUT THE WRITTEN PERMISSION OF HUBBARD ENTERPRISES IS PROHIBITED.

HUBBARD ENTERPRISES

HOLDRITE®

"Converting Makeshift Methods into Engineered Solutions"