

# PRODUCT SPECIFICATION DRAWING

## HOLDRITE® Stout Clamp™ #280

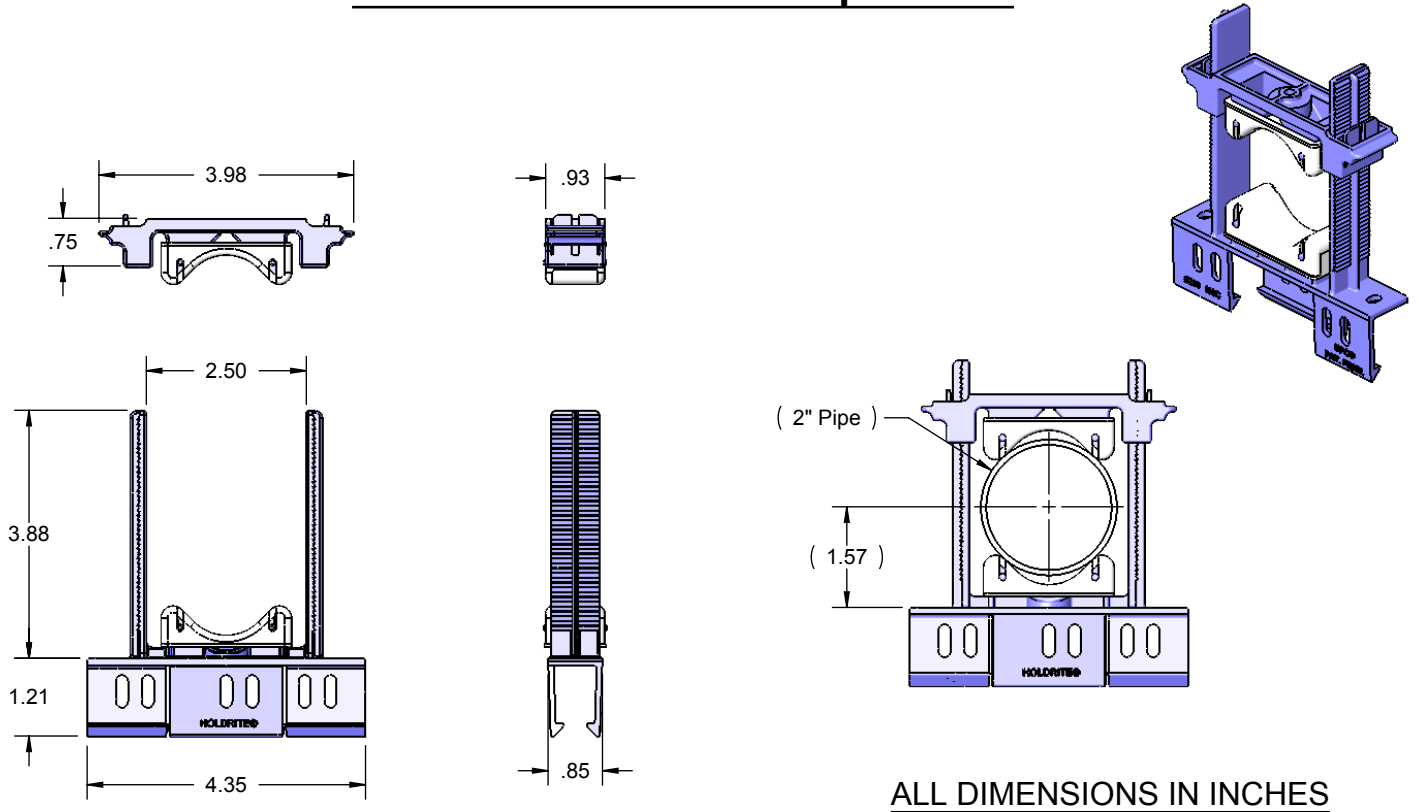

**Sound rated variable closure clamp that may be installed to HOLDRITE® EZ-Strut™ or Stout Brackets™ with only one to three screws (for maximum load in suspension mode). Two acoustical inserts isolate the pipe from the supporting structure, reducing waterline noise and vibration, while allowing normal pipe expansion and contraction. Variable closure clamp supports 1" - 2" CTS and IPS pipe sizes. Supports Copper, PEX, CPVC tubing, conduit, etc. Frame complies with UL94V-2 frame rating.**

### Product Information:

- Material:  
Top & Bottom Clamp: Nylon, medium blue, FR UL94V-2  
Pads: TPR, natural (off-white), 50 shore A
- Temperature range: -10 °F to +180 °F
- Load rating: 75 lbs in suspended mode, 300 lbs maximum in top mount
- Patent Pending
- UPC / IPC / IAPMO listed



THIS INFORMATION IS PROPRIETARY TO HUBBARD ENTERPRISES AND IS SUBJECT TO CHANGE WITHOUT NOTICE. ANY REPRODUCTION IN PART OR WHOLE WITHOUT THE WRITTEN PERMISSION OF HUBBARD ENTERPRISES IS PROHIBITED.

**••••HUBBARD ENTERPRISES••••**  
**HOLDRITE®**  
*"Converting Makeshift Methods into Engineered Solutions"*

Product Submittal	
Job Name:	
Date:	
Part Number:	Qty:
Architect / Owner:	
Contractor:	
Notes:	