

PRODUCT SPECIFICATION DRAWING

QUICK STAND™ #50-SWHP-W

Wall Mounted Equipment Platform

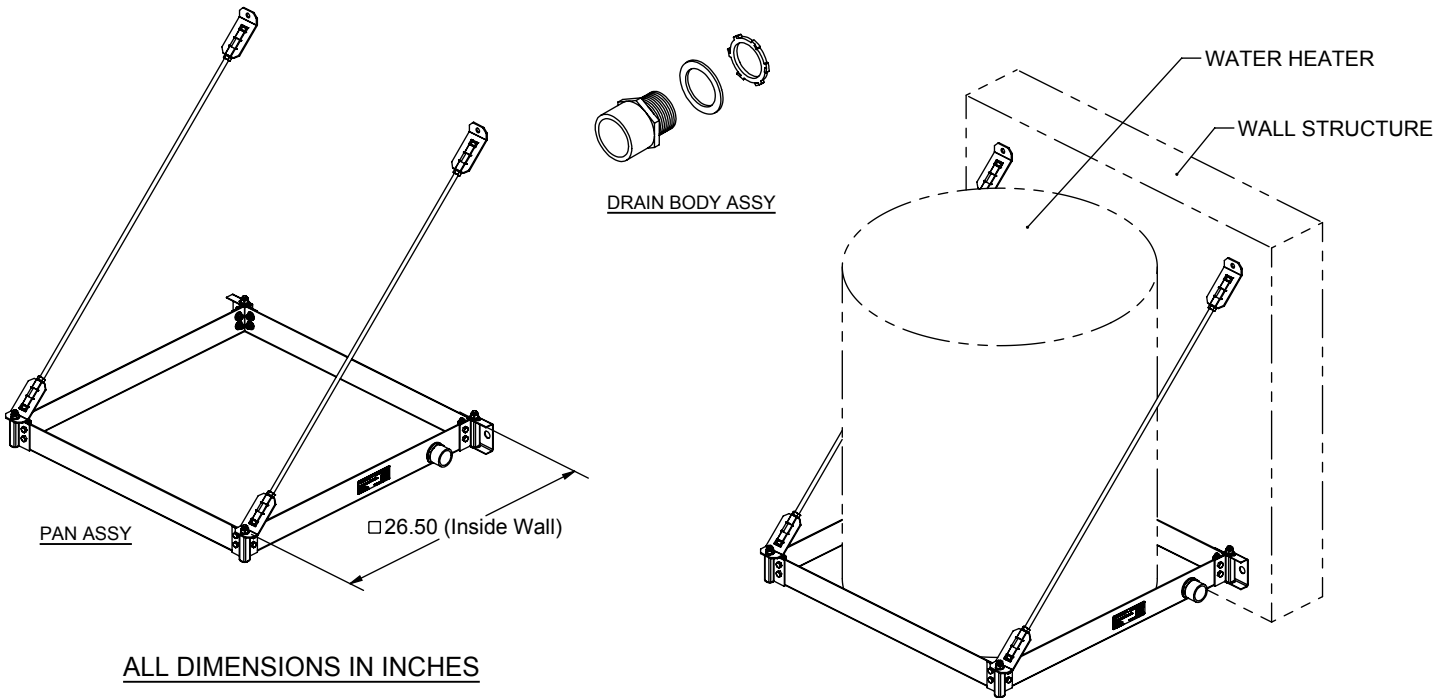

ALL DIMENSIONS IN INCHES

The Wall Mounted Equipment Platform is engineered to support water heaters up to 50 gallons (or other equipment up to 600 pounds total weight) mounted to a wall. This item also serves as a drain pan.

Product Information:

- Material:
 - Pan: 12 gage CRS, galvanized
 - Corner Brackets (4): 14 gage CRS, galvanized
 - C-Brackets (2): 16 gage CRS, galvanized
 - 45° Brackets (4): 12 gage, CRS, galvanized
 - Threaded Rod (2): Low carbon steel, zinc plated, 3/8" x 37.10" long
- Wide platform allows water heaters up to 26-1/2" diameter
- Watertight corners and drain fittings eliminate need for additional drain pan
- Static load rating 600 pounds with 2X safety factor (depending on structural anchorage)
- Professional Engineer stamped documentation available
- Includes PVC drain body 1" MIPT x 1" FS
- Galvanized steel construction
- Suspends with user supplied 3/8" hardware to mount to wall, 4 places
- Installation instructions for mounting to concrete or framed wall structure available
- Patent Pending

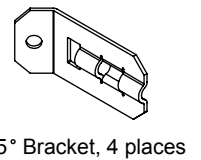
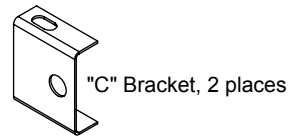

THIS INFORMATION IS PROPRIETARY TO HUBBARD ENTERPRISES AND IS SUBJECT TO CHANGE WITHOUT NOTICE. ANY REPRODUCTION IN PART OR WHOLE WITHOUT THE WRITTEN PERMISSION OF HUBBARD ENTERPRISES IS PROHIBITED.

.....HUBBARD ENTERPRISES.....
HOLDRITE®
 "Converting Makeshift Methods into Engineered Solutions"

Product Submittal	
Job Name:	
Date:	
Part Number:	Qty:
Architect / Owner:	
Contractor:	
Notes:	