

PRODUCT SPECIFICATION DRAWING

HOLDRITE® Silencer™ #265 Acoustical Shower Head/Tub Spout Clamp

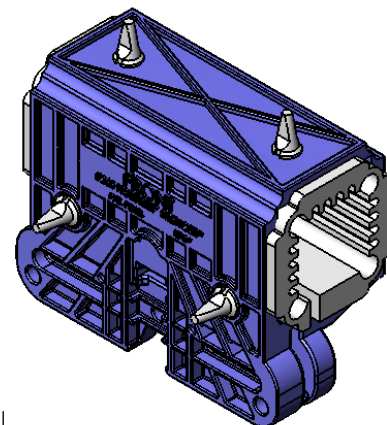
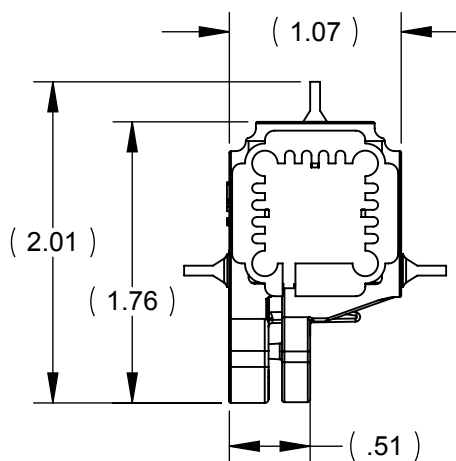
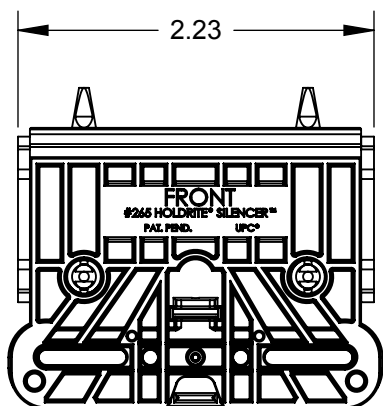
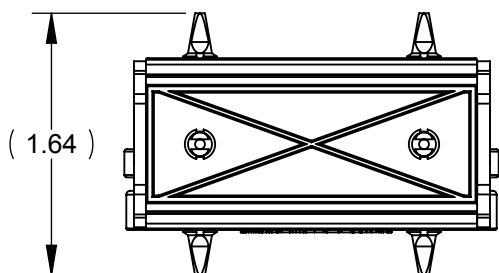

ALL DIMENSIONS IN INCHES

The **HOLDRITE Silencer #265 Acoustical Shower Head/Tub Spout Clamp** is a strong and effective clamp for minimizing the noise generated at the shower or similar application. This clamp is designed for attachment to the Holdrite Stout Bracket® and accepts a drop eared 90° ell or similar fitting.

Product Information:

- **Materials:**
 Shell: Polypropylene, medium blue, UL94V-2
 Isolator: Santoprene, 40 to 45 shore A, natural (off-white)
 Screw Plate: 16 gage CRS, zinc plated
- Patent Pending
- UPC / IPC / IAPMO listed

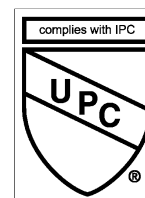

THIS INFORMATION IS PROPRIETARY TO HUBBARD ENTERPRISES AND IS SUBJECT TO CHANGE WITHOUT NOTICE. ANY REPRODUCTION IN PART OR WHOLE WITHOUT THE WRITTEN PERMISSION OF HUBBARD ENTERPRISES IS PROHIBITED.

.....HUBBARD ENTERPRISES.....
HOLDRITE®
 "Converting Makeshift Methods into Engineered Solutions"

Product Submittal	
Job Name:	
Date:	
Part Number:	Qty:
Architect / Owner:	
Contractor:	
Notes:	