

PRODUCT SPECIFICATION DRAWING

HOLDRITE® Stout Clamp™ #285

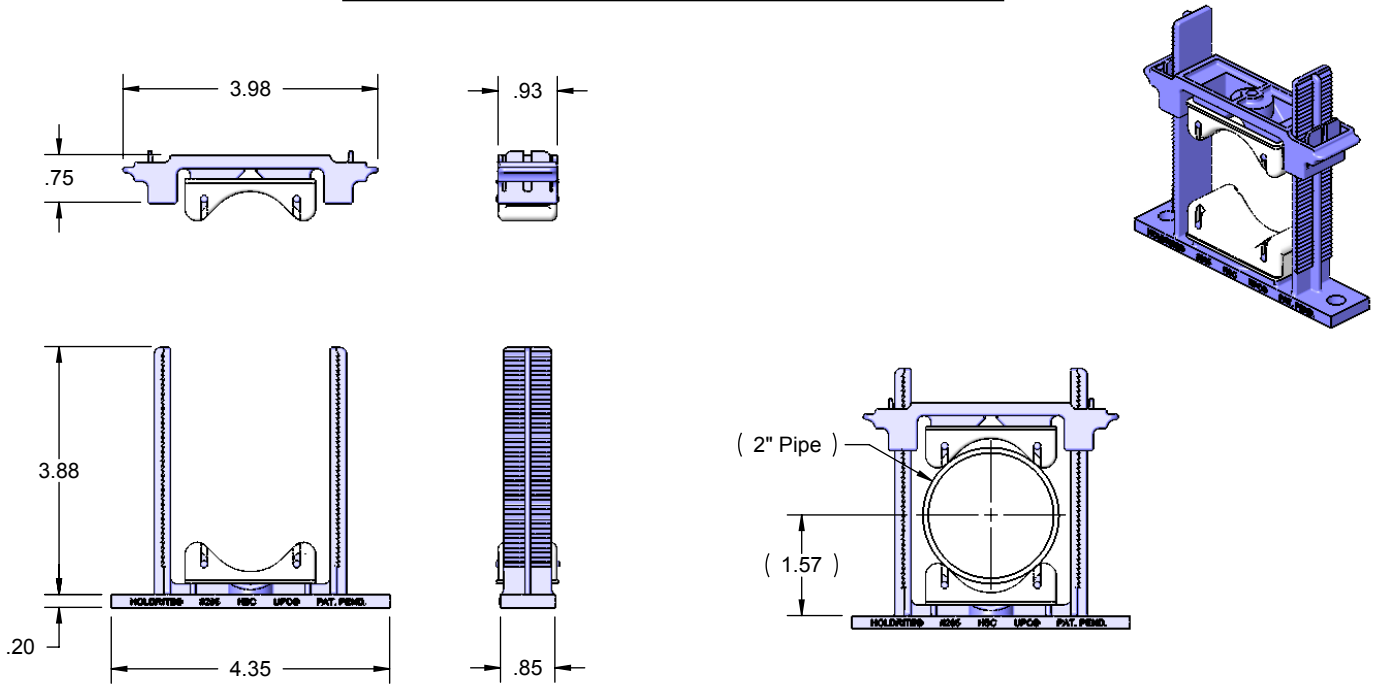

ALL DIMENSIONS IN INCHES

Sound rated variable closure clamp that may be installed as a standard "two-hole" pipe clamp to flat surfaces, to HOLDRITE® EZ-Strut™ or Stout Brackets™ with one or two screws (for maximum load), or to flat surfaces by using 2 @ 1/4" hammer-set or other anchors. Two acoustical inserts isolate the pipe from the supporting structure, reducing waterline noise and vibration, while allowing normal pipe expansion and contraction. Variable closure clamp supports 1" - 2" CTS and IPS pipe sizes. Supports Copper, PEX, CPVC tubing, conduit, etc. Frame complies with UL94V-2 fire rating.

Product Information:

- Material:
 - Top & Bottom Clamp: Nylon, medium blue, FR UL94V-2
 - Pads: TPR, natural (off-white), 50 shore A
- Temperature range: -10°F to +180°F
- Load rating: 75 lbs in suspended mode, 300 lbs maximum in top mount
- Patent Pending
- UPC / IPC / IAPMO listed



THIS INFORMATION IS PROPRIETARY TO HUBBARD ENTERPRISES AND IS SUBJECT TO CHANGE WITHOUT NOTICE. ANY REPRODUCTION IN PART OR WHOLE WITHOUT THE WRITTEN PERMISSION OF HUBBARD ENTERPRISES IS PROHIBITED.

.....HUBBARD ENTERPRISES.....
HOLDRITE®
 "Converting Makeshift Methods into Engineered Solutions"

Product Submittal	
Job Name:	
Date:	
Part Number:	Qty:
Architect / Owner:	
Contractor:	
Notes:	