

# PRODUCT SPECIFICATION DRAWING HOLDRITE® HANGOVER™ #125 & #125-L

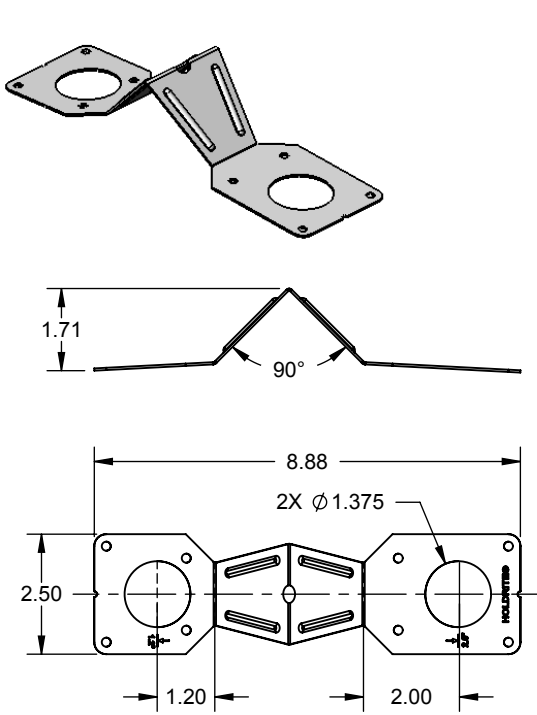

**#125**

ALL DIMENSIONS IN INCHES

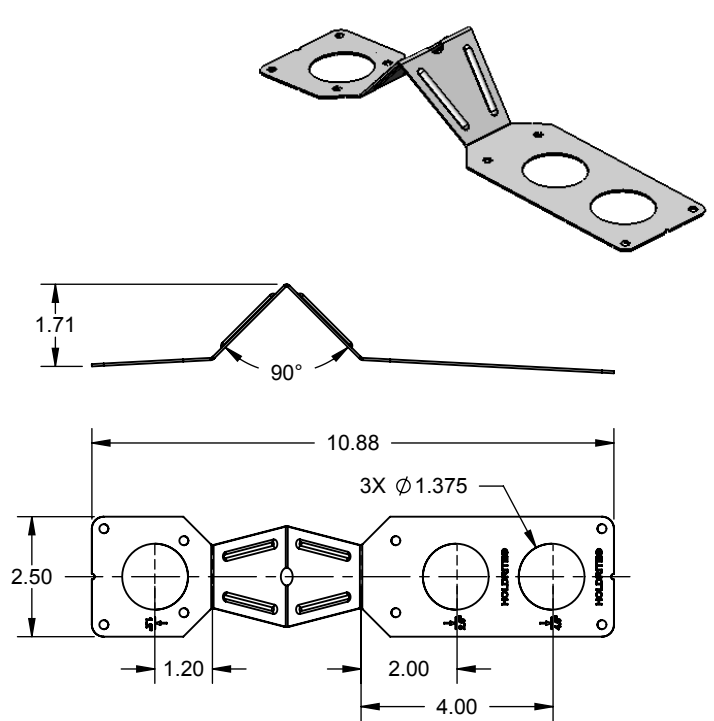

**#125-L**

The **HOLDRITE® HANGOVER™** concrete insert brackets are installed on wood forms for use with cast-in-place concrete slabs. When the wood forms are stripped away, the **HOLDRITE® HANGOVER™** bracket is ready to support up to 1" CTS for horizontal pipe runs.

## Product Information:

- Material: 18 gage CRS, galvanized per ASTM-A653, G90
- Load rating: 150 pound load rating in 3000 psi concrete, safety factor = 3
- Complies with load requirements of MSS SP-58
- Supports 1/2", 3/4" and 1" tubing with available inserts
- Patent Pending

THIS INFORMATION IS PROPRIETARY TO HUBBARD ENTERPRISES AND IS SUBJECT TO CHANGE WITHOUT NOTICE. ANY REPRODUCTION IN PART OR WHOLE WITHOUT THE WRITTEN PERMISSION OF HUBBARD ENTERPRISES IS PROHIBITED.

.....HUBBARD ENTERPRISES.....  
**HOLDRITE®**  
 "Converting Makeshift Methods into Engineered Solutions"

Product Submittal	
Job Name:	
Date:	
Part Number:	Qty:
Architect / Owner:	
Contractor:	
Notes:	