

PRODUCT SPECIFICATION DRAWING

HOLDRITE® #121-DS

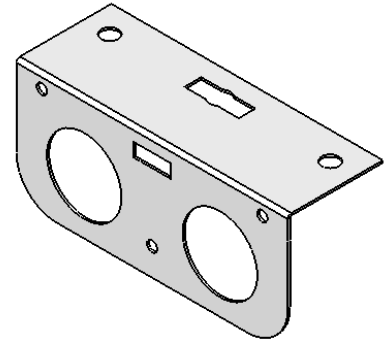
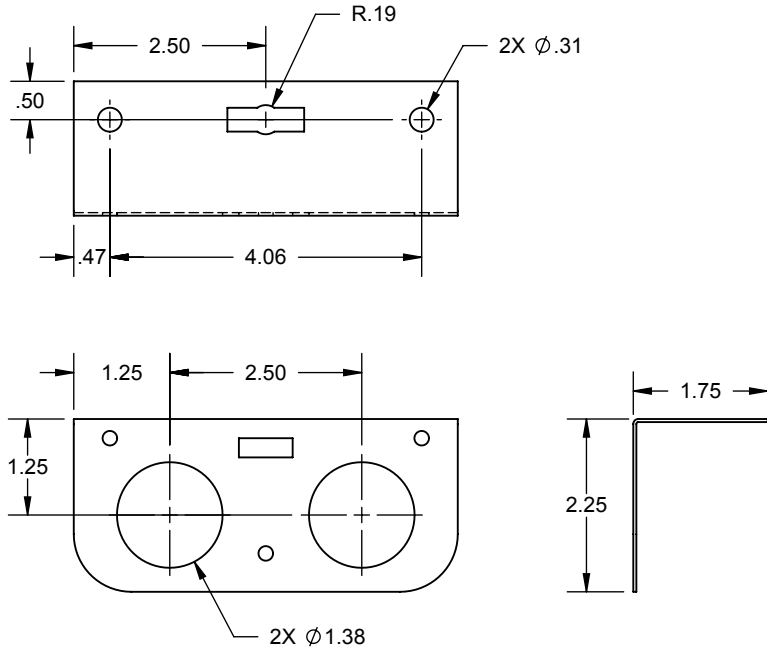

ALL DIMENSIONS IN INCHES

The **HOLDRITE® #121-DS** is a 20 gage galvanized steel bracket that supports dual lines of 1/2", 3/4" or 1" Copper, PEX or CPVC tubing at 1-1/4" center line height. The hole pattern on the 90° base allows for attachment to any flat surface. The bracket can also be suspended by 3/8" threaded rod.

Product Information:

- Material: 20 gage CRS, galvanized
- Load rating: 25 pounds
- Supports 1/2", 3/4" and 1" tubing with available inserts
- UPC / IPC / IAPMO listed

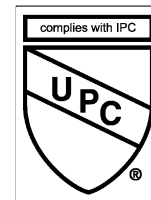

Product Submittal	
Job Name:	
Date:	
Part Number:	Qty:
Architect / Owner:	
Contractor:	
Notes:	

THIS INFORMATION IS PROPRIETARY TO HUBBARD ENTERPRISES AND IS SUBJECT TO CHANGE WITHOUT NOTICE. ANY REPRODUCTION IN PART OR WHOLE WITHOUT THE WRITTEN PERMISSION OF HUBBARD ENTERPRISES IS PROHIBITED.

••••HUBBARD ENTERPRISES••••
HOLDRITE®
"Converting Makeshift Methods into Engineered Solutions"