

PRODUCT SPECIFICATION DRAWING HOLDRITE® #109-N-6 BRACKET

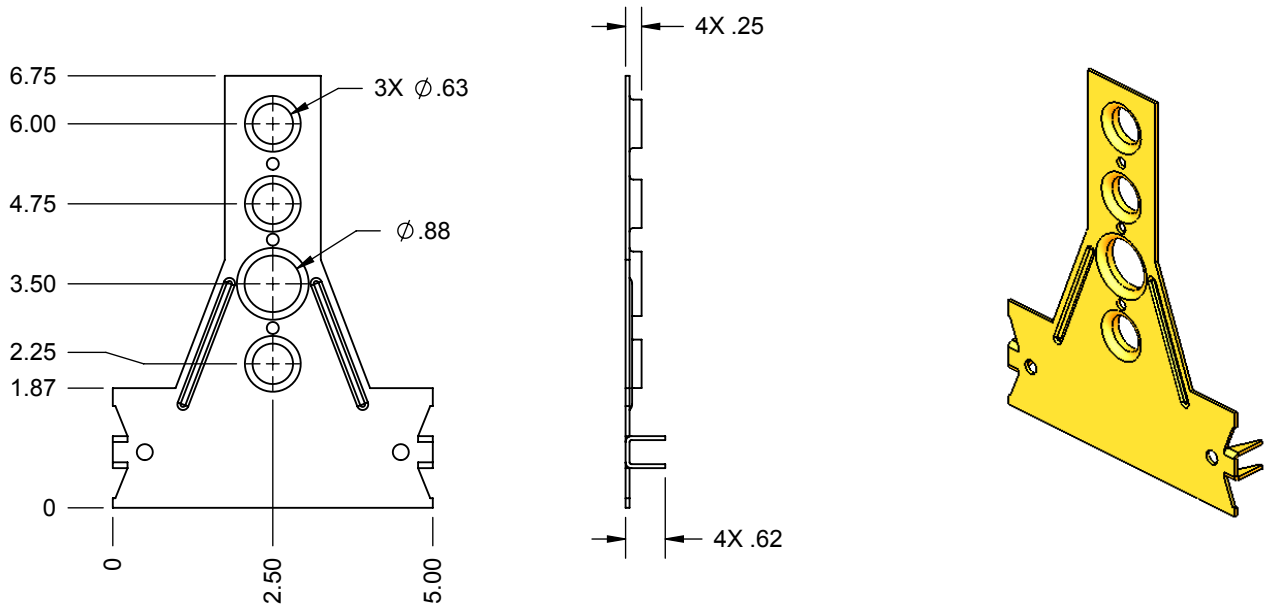

ALL DIMENSIONS IN INCHES

The HOLDRITE #109-N-6 is a Copper-Bonded™ steel bracket made to position 1/2" or 3/4" copper tube. Specifically designed to mount 1/2" stub-outs exactly 6" from the floor, with additional 5/8" holes at 2-1/4" and 4-3/4". There is a single 7/8" hole at the height of 3-1/2" for a hose bib, etc. This bracket also functions as a nail plate.

Product Information:

- Material: 16 gage CRS, Copper-Bonded™
- Patent pending
- UPC / IPC / IAPMO listed

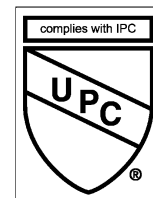

THIS INFORMATION IS PROPRIETARY TO HUBBARD ENTERPRISES AND IS SUBJECT TO CHANGE WITHOUT NOTICE. ANY REPRODUCTION IN PART OR WHOLE WITHOUT THE WRITTEN PERMISSION OF HUBBARD ENTERPRISES IS PROHIBITED.

.....HUBBARD ENTERPRISES.....
HOLDRITE®
 "Converting Makeshift Methods into Engineered Solutions"

| Product Submittal | |
|--------------------|------|
| Job Name: | |
| Date: | |
| Part Number: | Qty: |
| | |
| Architect / Owner: | |
| Contractor: | |
| Notes: | |
| | |
| | |