

PRODUCT SPECIFICATION DRAWING

QUICK STRAP® #QS-120

Seismic support for water heaters

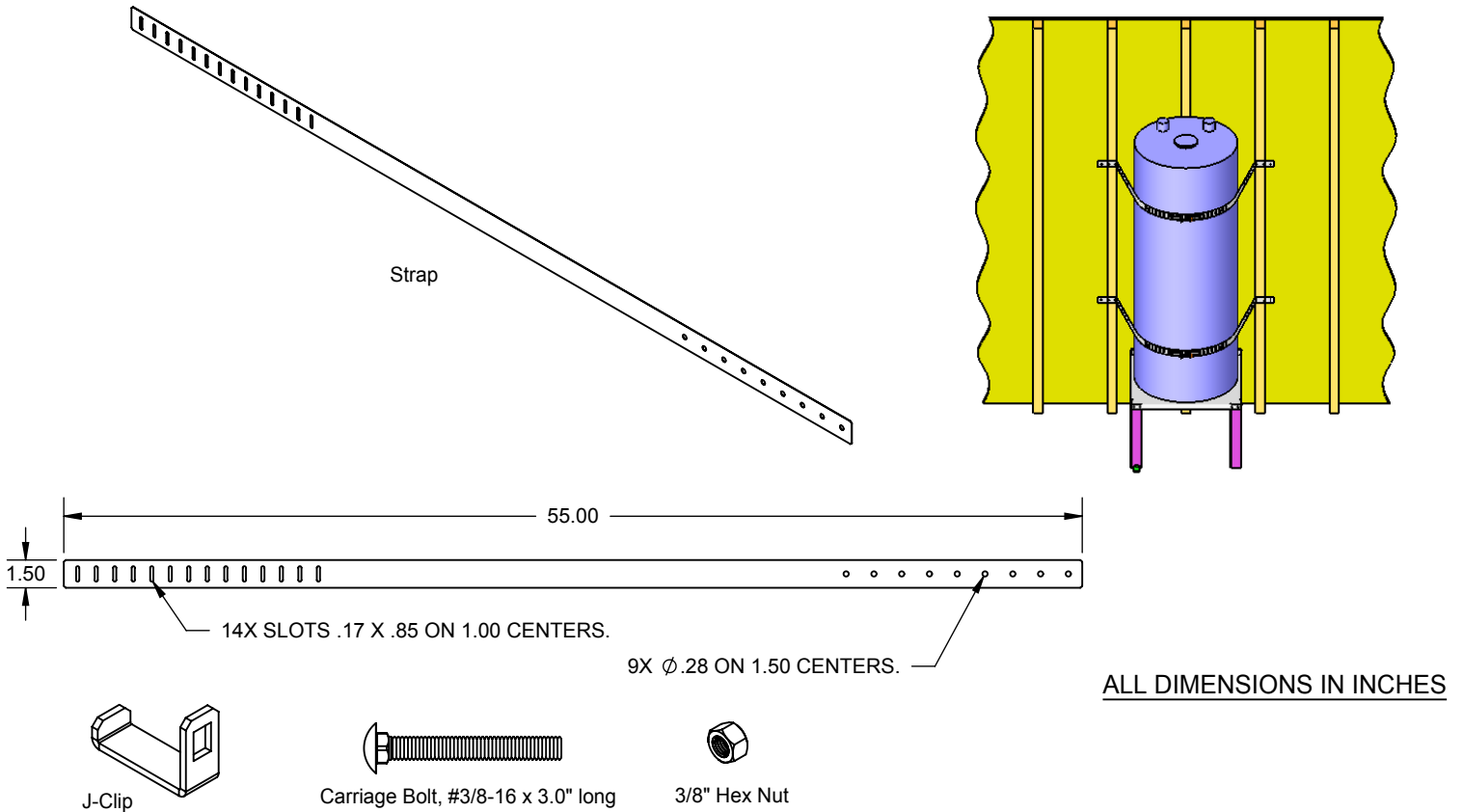

The **QUICK STRAP® #QS-120** is a seismic/earthquake support system for water heaters up to 120 gallons in size. The system includes: (4) Straps, (2) J-Clips, (2) 3/8" Carriage Bolts and (2) 3/8" Hex Nuts. The Quick Link® system allows for full adjustment from the front side of the water heater.

Product Information:

- Material: Strap, 24 gage CRS, galvanized
- California Division State Architect (DSA) approval #98-018
- UPC / IPC / IAPMO listed

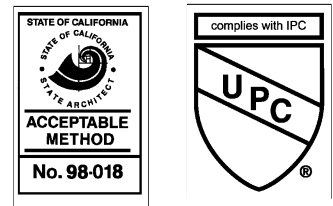

THIS INFORMATION IS PROPRIETARY TO HUBBARD ENTERPRISES AND IS SUBJECT TO CHANGE WITHOUT NOTICE. ANY REPRODUCTION IN PART OR WHOLE WITHOUT THE WRITTEN PERMISSION OF HUBBARD ENTERPRISES IS PROHIBITED.

.....HUBBARD ENTERPRISES.....
HOLDRITE®
"Converting Makeshift Methods into Engineered Solutions"

Product Submittal	
Job Name:	
Date:	
Part Number:	Qty:
Architect / Owner:	
Contractor:	
Notes:	