

NEW!



VST-36/40/47/52-I

Articulated/Telescopic Aerial Lift

DEMAND BETTER

Up to 1000 lbs. of Jib Capacity

Up to 600 lbs. of Platform Capacity w/out Jib

180° Hydraulic Platform Rotation

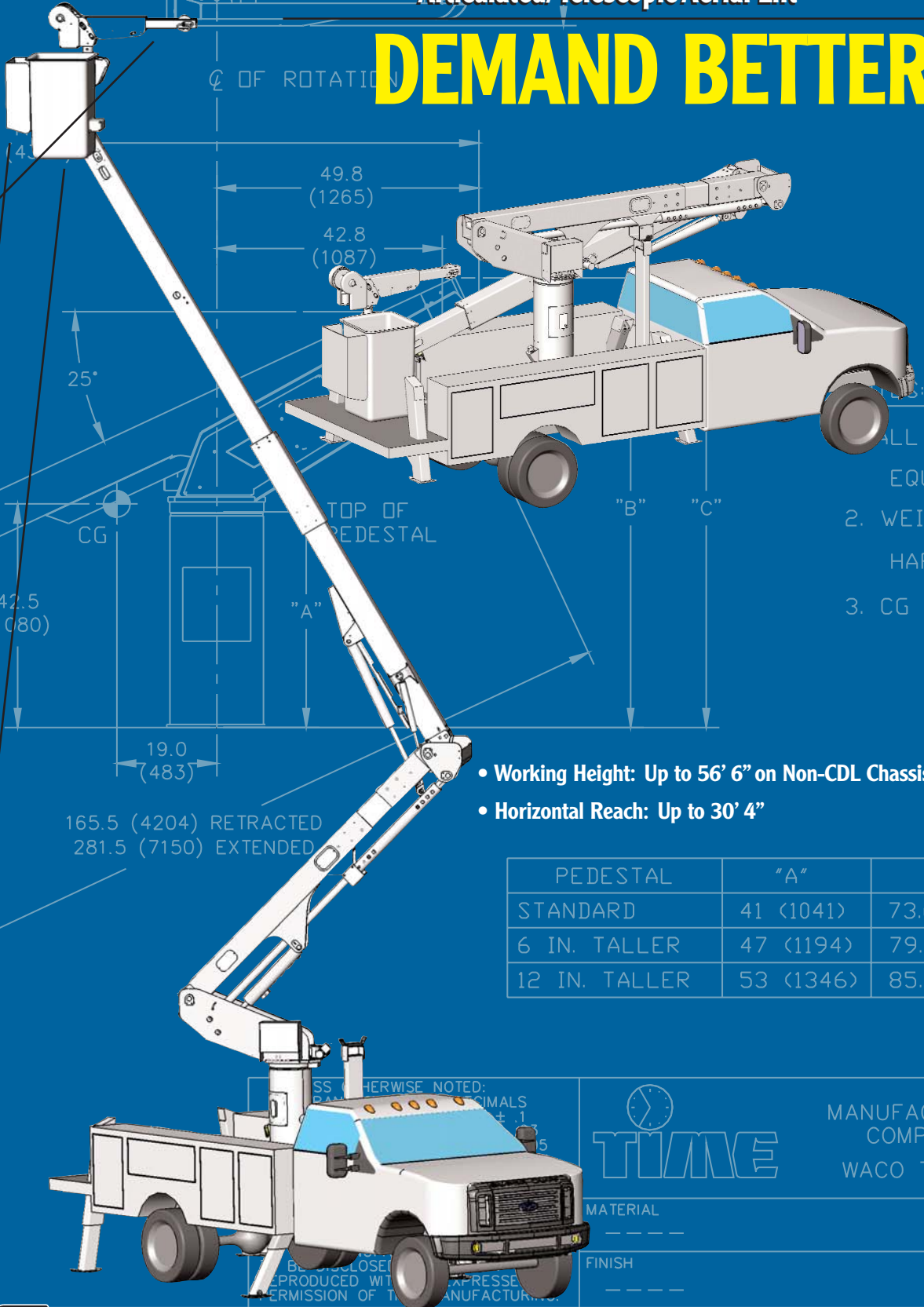

- Working Height: Up to 56' 6" on Non-CDL Chassis
- Horizontal Reach: Up to 30' 4"

PEDESTAL	"A"	"B"
STANDARD	41 (1041)	73.6 (2257)
6 IN. TALLER	47 (1194)	79.6 (2428)
12 IN. TALLER	53 (1346)	85.6 (2609)



For more information about the All-New VST-I series or any of the other outstanding VERSALIFT machines, contact your authorized VERSALIFT Distributor or call 1.800.825.1085



VST-36/40/47/52-I

Articulated/Telescopic Aerial Lift

GENERAL SPECIFICATIONS

(Based on 40" frame)

	VST-36-I	VST-40-I	VST-47-I	VST-52-I
Horizontal reach	26'-2"	30'-2"	30'-9"	30'-4"
Max platform capacity	600 lbs.	600 lbs.	500 lbs.	500 lbs.
Platform rotation	180°	180°	180°	180°
Max jib capacity	1000 lbs.	1000 lbs.	1000 lbs.	1000 lbs.
Bottom of platform height	36'-4"	40'-4"	46'-10"	51'-6"
Working height	41'-4"	45'-4"	51'-10"	56'-6"
Stowed travel height	10'-6"	10'-6"	11'-0"	11'-6"

BOOM ACTION

Outer/Inner boom articulation	-25 to +85°	-25 to +85°	-25 to +85°	-25 to +85°
Inner boom extension	79"	103"	103"	53"
Lower boom articulation	0 to 87°	0 to 87°	0 to 84°	0 to 84°
Rotation	360°	360°	360°	360°

INSULATION (where applicable)

Upper boom insulation gap	46"	46"	64"	64"
Lower boom insulation gap	12"	12"	12"	12"

VEHICLE REQUIREMENTS

Cab to axle (minimum)	60"	84"	84"	102"
GVWR	17,500 lbs.	17,500 lbs.	17,500 lbs.	24,000 lbs.

NOTE:

- Specifications may vary without prior notification.
- Required GVWR can vary significantly with chassis, lift mounting location, service body, accessories, and desired payload.

OPTIONS

- Auxiliary Outriggers
- Second Set of Tool Power Ports
- Lifting Eye
- Emergency Power
- Two-Speed Manual Throttle Control
- Hydraulic or Manual Jib and Winch Available
- Various Pedestal Heights

