



Environmental Products

*Modules combine efficient drum storage, positive spill control, and safe liquid dispensing.*

The **GATOR® Drum Management System** meets safety and environmental protection requirements while organizing drum storage for maximum efficiency, productivity, and cost savings. The design accommodates either 30- or 55-gallon (110L & 200L) steel drums of Class 1B or 1C flammables and combustibles. Space-saving design is also ideal for storage of non-hazardous liquids. Gator-Tuff, UV-protected polyethylene construction provides maximum chemical compatibility and resistance – preventing corrosion and deterioration, assuring a long lifetime of service. Molded-in drum lock channels hold drums in place. The system consists of three modules: base, stack and dispensing shelf.

**The Base Module** is the key component of the system. It is designed to accommodate two drums with a load capacity of 3,000 lbs. (1361kgs) in total. The dispensing well conveniently holds either five-gallon safety cans or five-gallon pails. Forklift channels facilitate relocation within the plant. The system's generous 66-gallon (250L) "open-view" spill containment sump is located in the module. Spills, even drips of hazardous chemicals, are easy to spot and quickly cleaned up with this wide open design.

**The Stack Module** doubles system capacity holding two additional drums. Load capacity is 1500 lbs. (680kgs). It is forkliftable to aid in lifting drums on top of base module. When storing both 30- and 55-gallon (110L & 200L) drums, the smaller drums should be placed on top in this stack module. Do not mix lower drum sizes when double-stacking. Stack module includes a safety strap to use when stacking on base module to secure four-drum load.

**The Dispensing Shelf** has a load capacity of 60 lbs. (27kgs), and mounts securely to the stack module for convenient dispensing from the upper level.

# GATOR®



AK28902 Base  
AK28903 Stacker with strap  
AK28904 Shelf

Suitable for steel drums!



AK28904  
Dispensing Shelf  
reduces the risk of spills.

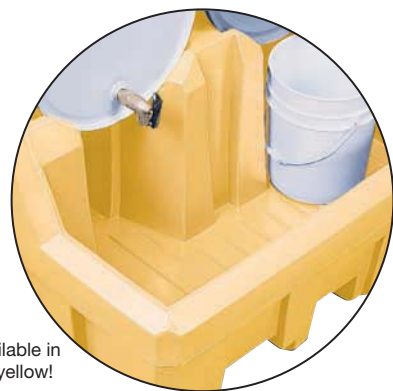

Open-view Sump makes  
spill detection and clean-up easy!

**EPA  
COMPLIANT**



Leading the  
Advancement of Safety

**"OPEN-VIEW" SUMP**

For safe, effective cleanup of spills, only Gator® offers a unique "open-view" sump design. Whereas others hide dangerous spills within the walls of the unit itself, Gator® makes spill detection as easy as a simple glance! No need to remove drums to clean-up as in other "cradle" units.

**Gator® Drum Management System**

Product Description	Sump Cap. Gallons	Load Bearing Capacity Lbs (kgs.)	Outside Dim. W x D x H (mm)	Compliance	Gray Model No.	Yellow Model No.
Base module	66/250L	3000 (1361)	49" x 59" x 26"(1245 x 1499 x 660)	EPA,U	AK28902	AK28902Y
Stack module	-	1500 (680)	49" x 46" x 12"(1245 x 1168 x 305)	-	AK28903	AK28903Y
Dispensing shelf	-	60 (27)	19 1/2" x 18 3/4" x 16 1/2"(495 x 476 x 419)	-	AK28904	AK28904Y

\*See page 8 for Regulation Key.

