

Chain-O-Flex Overhead Conveyors

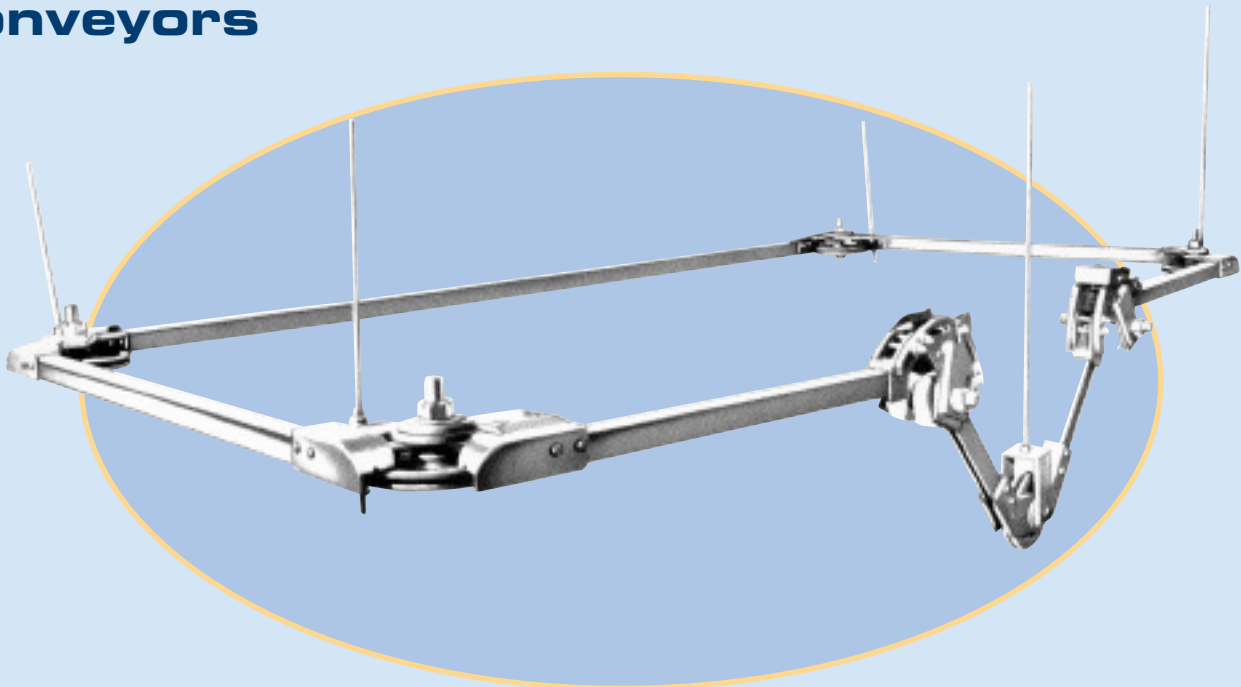

Modular • Bolted Construction • Do-It-Yourself • Floor Or Ceiling Mounted

The modular construction of the COF Series is a must for any progressive company. This unique construction allows for easy modification due to growth or product change, etc. This overhead conveyor is offered in standard lengths of 10 feet, but can be modified to any other size. These units can be suspended from the ceiling or are self-standing.

The fact that it has fewer moving parts lends itself to long life and virtually maintenance-free operation. This design works well in high heat conditions, such as powder or other paint applications. In excessive heat special bearings are available.

We also offer a multi-level installation. Other features include vertical dip hardware which allows for assembly, cleaning, and painting at various elevations. It has unlimited applications. If you have a particular requirement that does not lend itself to our standard system, consult factory for engineering assistance.

