

Ball Transfer Table

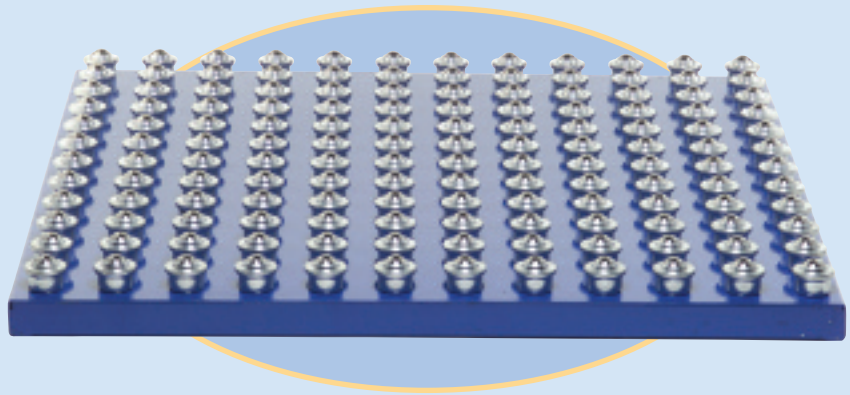



The ball transfer table is ideal for products which must be rotated or positioned from one work station to another. Steel balls are friction-free and easily glide boxes, packages, etc. in any direction. Can be floor mounted or placed on adjustable H-stands for work-height jobs. Three separate ball styles available. Custom sizes optional: stainless steel tables, stainless or nylon ball, etc.



► BTT SERIES STANDARD TABLE TOP

Size In	2" SPACING		3" SPACING		4" SPACING		6" SPACING	
	Model No	Weight Lbs	Model No	Weight Lbs	Model No	Weight Lbs	Model No	Weight Lbs
24 x 24	BTT-2424-2	67	BTT-2424-3	54	BTT-2424-4	48	BTT-2424-6	35
24 x 36	BTT-2436-2	98	BTT-2436-3	73	BTT-2436-4	56	BTT-2436-6	49
24 x 48	BTT-2448-2	131	BTT-2448-3	100	BTT-2448-4	81	BTT-2448-6	67
36 x 36	BTT-3636-2	143	BTT-3636-3	110	BTT-3636-4	95	BTT-3636-6	69
36 x 48	BTT-3648-2	192	BTT-3648-3	145	BTT-3648-4	115	BTT-3648-6	91
48 x 48	BTT-4848-2	250	BTT-4848-3	189	BTT-4848-4	150	BTT-4848-6	123

Ball Options

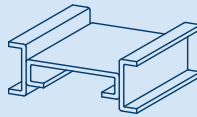
					
<p>Model 1001 (Standard) 1" ball has cap. of 65 lbs; Stem mount 1/4-20 thread; 1-9/16" high.</p>	<p>Model 101 (Optional) 1" ball has cap. of 75 lbs; 1-3/16" high.</p>	<p>Model 201 (Optional) 1-1/2" ball has cap. of 250 lbs; 1-13/16" high.</p>	<p>Pan Mount (Standard) Mounted with choice of 2, 3, 4 or 6" centers; Material is 12 ga. 1-3/4" high.</p>	<p>Conveyor Mount (Optional) Mounted with choice of 2, 3, 4 or 6" centers; Material is 12 ga.</p>	<p>Conveyor Channel Mount (Optional) Centers generally mounted 3, 4, or 6". Steel thickness is 12 ga.</p>

Ball Transfer Rails

These single-frame rails are custom designed for transfer systems. The ball transfers allow for fast change-of-load direction. Available in 5' or 10' lengths with 1" or 1-1/2" ball transfers.



► BTR SERIES

Ball Center Spacing In	Capacity Per Ball	5 FT		10 FT	
		Model No.	Weight Lbs	Model No.	Weight Lbs
MODEL 1001 • LIGHT DUTY BALL • 2-1/2 X 1-12 GAUGE GALVANIZED CHANNEL					
3	65	BTRL-3-5	16	BTRL-3-10	31
4	65	BTRL-4-5	14	BTRL-4-10	27
6	65	BTRL-6-5	12	BTRL-6-10	23
MODEL 101 • MEDIUM DUTY BALL • 2-1/2 X 1-12 GAUGE GALVANIZED CHANNEL					
3	75	BTRM-3-5	16	BTRM-3-10	31
4	75	BTRM-4-5	14	BTRM-4-10	27
6	75	BTRM-6-5	12	BTRM-6-10	23
MODEL 201 • HEAVY DUTY BALL • 3-1/2 X 1-10 GAUGE PAINTED CHANNEL					
6	250	BTRH-6-5	25	BTRH-6-10	50
12	250	BTRH-12-5	18	BTRH-12-10	36