

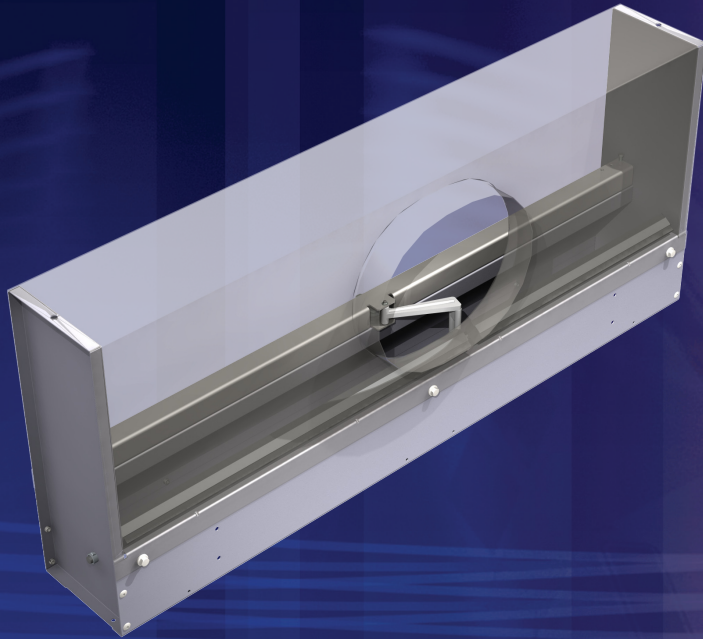

# DynaFuser™

solving the perimeter challenge.



## Another First from Titus

Introducing the revolutionary DynaFuser, the newest diffuser in a long history of innovative products from Titus.

This patent-pending linear slot diffuser solves the problem of overhead heating and cooling in perimeter applications. Powered by the supply air temperature, the DynaFuser automatically changes directional pattern controllers to the correct position for heating or cooling to provide optimal comfort.

The DynaFuser is an energy efficient and cost effective solution that puts the air where it needs to be.



- Intelligent Air Management
- Innovative Technology
- Cost Effective
- Energy Savings
- Enhanced Comfort
- Helps achieve LEED credits

Save energy and  
improve comfort with  
DynaFuser.



**Titus**  
The Leader in Air Management  
[www.titus-hvac.com](http://www.titus-hvac.com)

# DynaFuser Saves Energy During Heating Cycle

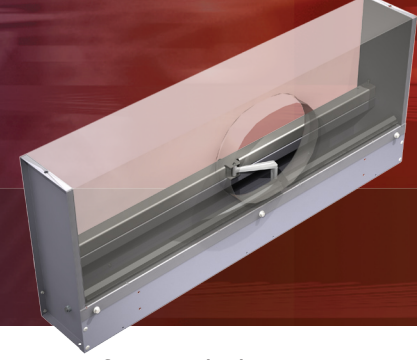

Most perimeter areas of commercial buildings require both heating and cooling. Typically a split overhead system uses two slot diffusers mounted end to end or one diffuser with multiple slots. In the two diffuser system, one diffuser is set for horizontal discharge and the other for vertical. With a multiple slot diffuser, half of the slots are set to discharge horizontally and half discharge vertically.

Even though these methods work, they are not the optimum solution. In both the heating and cooling modes, half the supply air is being discharged in the wrong direction. During heating, half the air is discharged horizontally which causes stratification along the ceiling. In cooling, half the air is discharged vertically causing unwanted drafts along the floor.

The Titus DynaFuser was designed to solve the perimeter challenge. The DynaFuser automatically changes the air discharge pattern to the correct position for heating and cooling applications. This allows 100% of the supply air to be utilized in either application to achieve optimum comfort in the occupied zone.

The DynaFuser not only increases the comfort level by correctly discharging supply air in both heating and cooling modes, it does so without the use of an internal or external power source which translates to energy savings for the building owner. When 100% of the supply air is utilized, the room temperature reaches the set-point faster requiring the HVAC

system to run for a shorter duration of time, which saves energy. Lab tests indicate energy savings from 10-40% during heating, which can help achieve the LEED-NC 2.2, Optimize Energy Performance credit.

The graph below shows the average room temperature as a function of time for the DynaFuser compared to a TBD-30 set in the split flow position. The test was setup in a 12ft x 19 ft room with a cold chamber with a 0.5 U value set at 29°F. Supply airflow is 170 cfm and 92°F.

During the 1 hour test, the TBD-30 in the split position never achieved an average room temperature over 71°F while the DynaFuser achieved 72°F in 13 minutes. If the room setpoint was 72°F, the thermostat would have been satisfied within 13 minutes with the DynaFuser, while the TBD-30 in the split flow position would run for over an hour. This longer running time is wasted energy.

Return temperature was also measured during this test. With the TBD-30 in the split flow position, the return temperature was 3.25°F higher than during the DynaFuser test. This equates to a loss of 26.5% of energy directly to the return because half of the airflow in the TBD-30 in the split flow position is directed to the ceiling and never reaches the occupied zone.

