



Bell & Gossett® DB - Differential Bypass



For hydronic systems utilizing zone valves.

- Controls excess flow in the system when there is reduction in demand
- Available in 3/4" connection
- All brass body with non-ferrous internals



DB – Differential Bypass Valve

Operating Data

Maximum working pressure: 150 PSIG (1,034 kPa)
 Maximum operating temperature: 230° F (110 °C)
 Adjustment range: 2 to 10 PSI

Materials of Construction

Valve bodyBrass
 Seals EPDM
 Spring..... Stainless Steel
 KnobABS

Description

The differential bypass valve is used in systems where heating loads may be excluded from the circuit as zone valves close. It controls the excess flow in the system by acting as a bypass while ensuring adequate flow to the remaining open circuits. The differential bypass valve helps reduce velocity noise caused by excess flow through the circuits while maintaining the pump head at a constant value.

Installation

The differential by-pass valve should be installed after the pump between the supply and return piping. It can be installed either in the horizontal or vertical position provided it is in accordance with the direction of flow as indicated by the arrow on the valve body.

Flow Rates

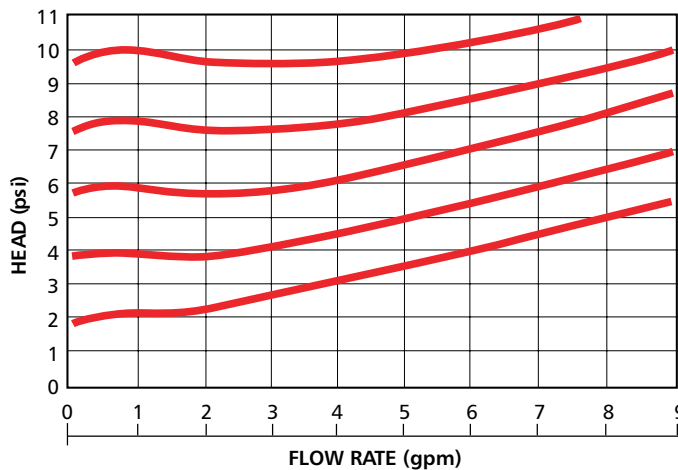

Dimensions

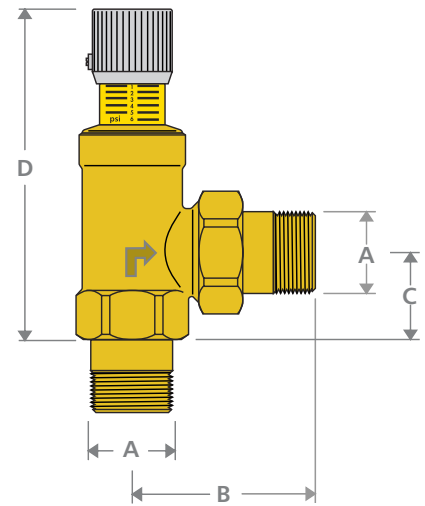

Recommended Installation

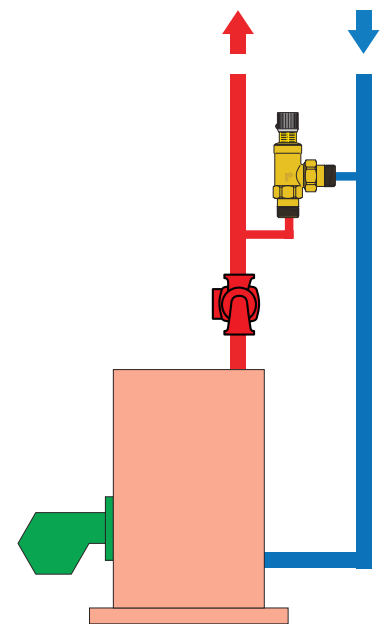

Dimensions and Weights

Model Number	Part Number	A (mm)	B (mm)	C (mm)	D (mm)	Connection Type	Weight (LB)
DB-3/4	113247	3/4" (19)	2-5/16" (59)	1" (26)	4" (104)	M NPT	1



ITT Corporation
 8200 N. Austin Avenue
 Morton Grove, Illinois 60053
 Phone: (847) 966-3700
 Fax: (847) 966-9052
 www.bellgossett.com

