



maintenance FREE

Bell & Gossett®
Series 60 In-Line Mounted *Centrifugal Pump*



The New Maintenance-Free Series 60 In-Line Mounted Pump

1. Maintenance-Free Pump and Motor Design

Bell & Gossett's time-proven three-piece design provides you with worry-free, install-and-forget operation and reliability.

2. Improved Hydraulic Performance

The use of sophisticated hydraulic design software results in expanded flow coverage, expanded pump sizes and operating efficiency improvements.

3. Smooth, Quiet Operation

The patented Bell & Gossett XL-11® Precision-Crafted Bearing System and application of advanced hydraulic design software provide an overall quieter level of operation.

4. Parts Interchangeability

Maintaining the overall flange-to-flange dimension is critical to providing quick replacement and turnaround times. The new Series 60 pump is capable of slipping into the same dimension as its predecessor.

5. Quality Product

The new Series 60 pump is produced at an ISO 9001-certified factory and is backed by a full, three-year flange-to-flange warranty.*

The New Maintenance-Free Series 60 In

Back to the future.

The new Series 60 is a blend of both past and future, incorporating Bell & Gossett's time-proven three-piece reliability with an all-new 21st century design. These technological advancements deliver a pump with a superior design, increased hydraulic performance and higher operating efficiencies for today's demanding applications.

Maintenance free.

The revolutionary XL-11® Precision-Crafted Bearing System is permanently lubricated... completely maintenance free... precisely positioned for long life and designed for smooth, quiet operation.



Quality and reliability.

The New Series 60 is made to the high B&G standards of quality and reliability that only a world-class ISO 9001-certified facility can deliver.

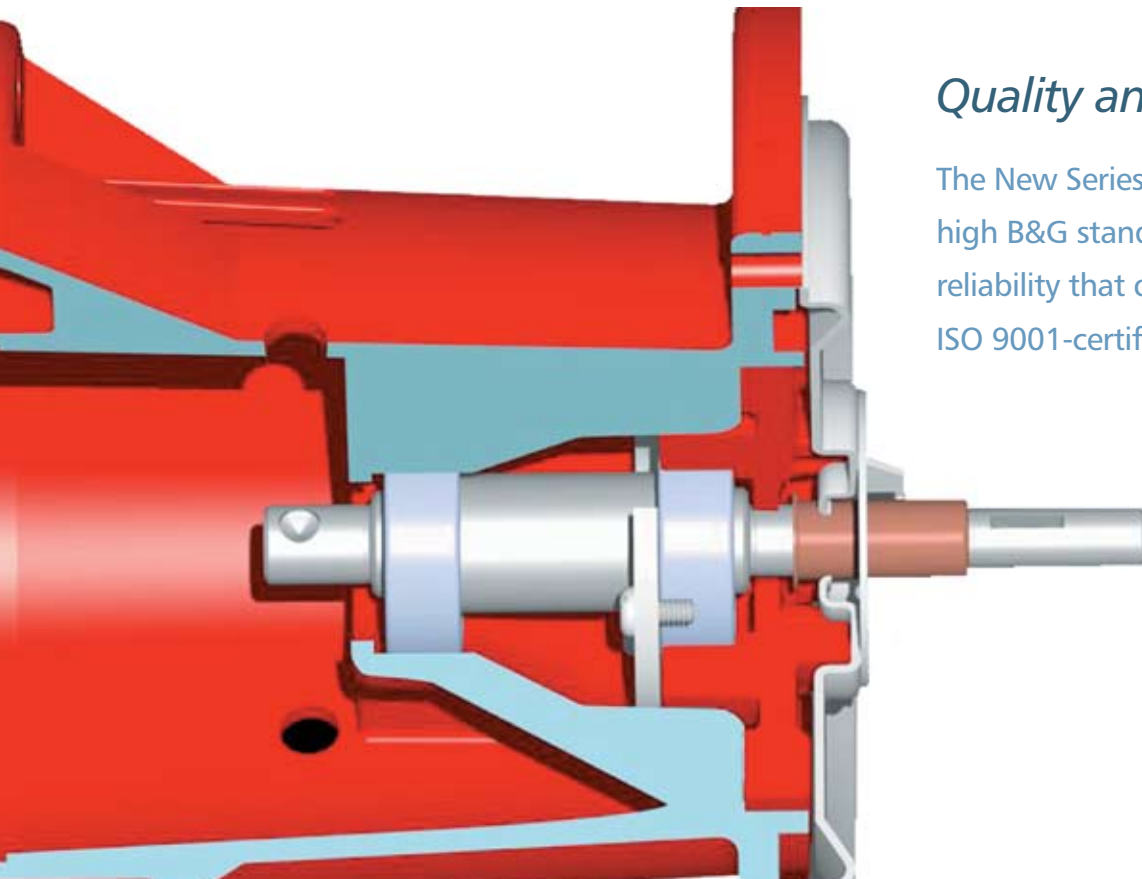

Quiet operation.

The XL-11® Precision-Crafted Bearing System, advanced fluid passage design and B&G permanently lubricated motor come together to deliver smooth, quiet, maintenance-free performance.

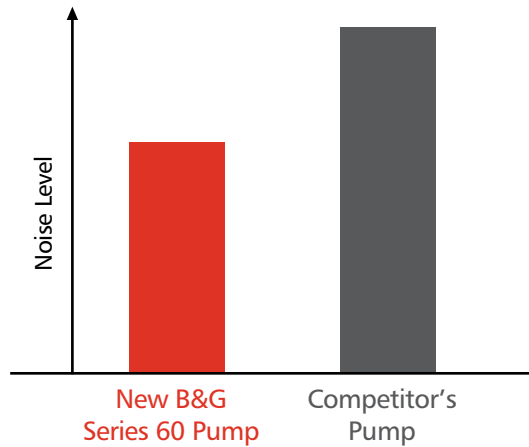

Internally self-flushing seal.

Bell & Gossett's open-seal chamber design provides superior flow circulation around the seal faces, resulting in reduced heat buildup, increased particle removal and superior seal-face flushing. It all adds up to long, trouble-free seal performance.

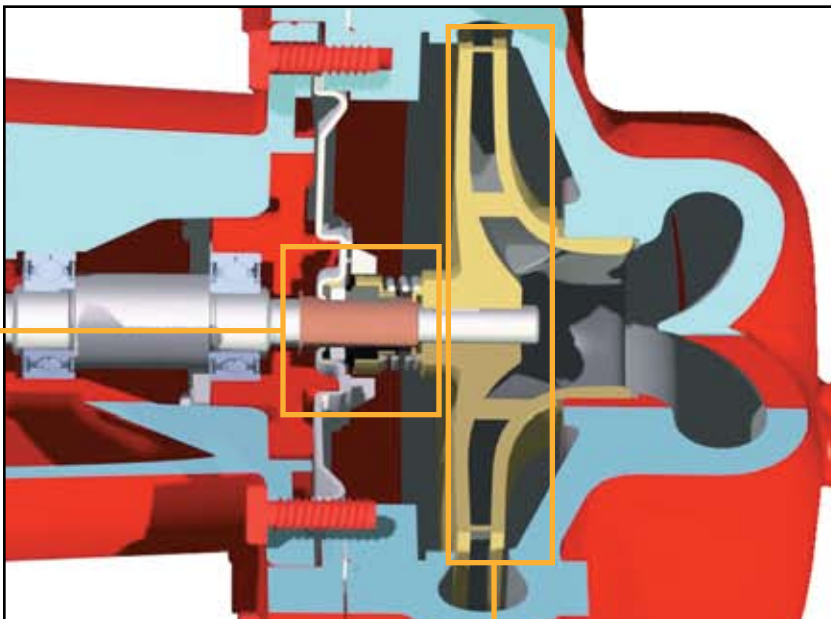

Impeller

State-of-the-art hydraulically balanced impellers and resilient-mounted motors provide smooth, quiet operation.

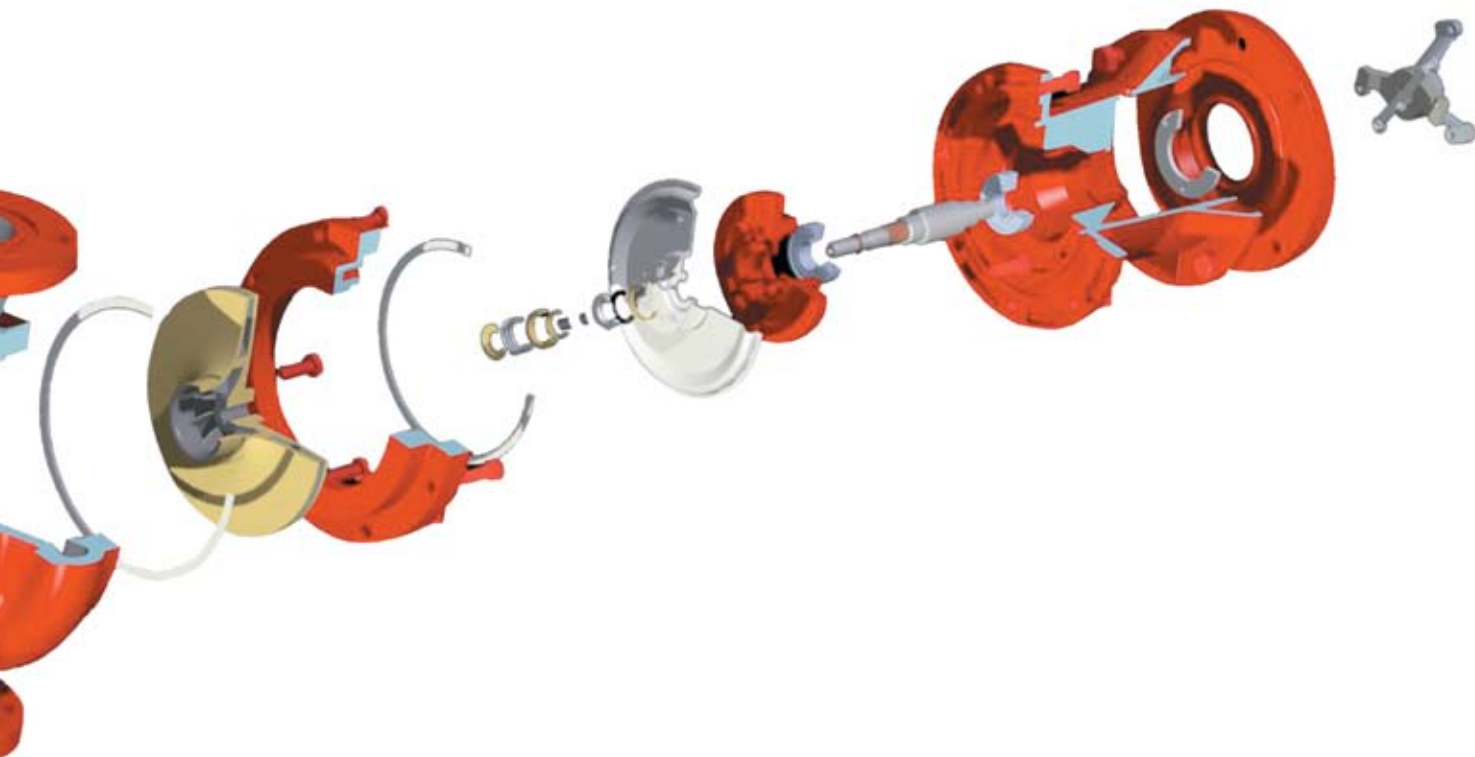

Materials of Construction

DESCRIPTION	BRONE-FITTED PUMP	ALL-BRONZE PUMP
Volute	Cast Iron ASTM #A159	Cast Bronze ASTM #B584
Face Plate	304 Stainless Steel	304 Stainless Steel
Impeller	Cast Bronze ASTM #B584	Cast Bronze ASTM #B584
Impeller Key	Carbon Steel	Carbon Steel
Impeller Lock Washer	Carbon Steel	Brass
Impeller Lock Nut	Plated Steel	Brass
Pump Shaft	Steel SAE 1144	Steel SAE 1144
Shaft Sleeve	Copper Alloy 110	Copper Alloy 110
Seal Assembly		
A. Housing	Brass ASTM #B36	Brass ASTM #B36
B. Bellow	Buna "N" (EPT Optional)	Buna "N" (EPT Optional)
C. Rotating Ring	Carbon	Carbon
D. Spring	#304 Stainless Steel	#304 Stainless Steel
E. Seat	Ceramic	Ceramic
F. Seat Gasket	Buna "N" (EPT Optional)	Buna "N" (EPT Optional)
Volute Gasket	Cellulose Fiber	Cellulose Fiber
Cover Plate (7" Impeller size only)	Cast Iron ASTM #A159	Cast Bronze ASTM #B584
Companion Flanges	1", 1-1/4" & 1-1/2" Formed Steel 2" Cast Iron ASTM #A159	1" & 1-1/4" Formed Brass 1-1/2" & 2" Cast Brass ASTM #B584

MECHANICAL SEAL SPECIFICATIONS:

Buna - pH Limitations 7-9; Temperature Range -20 to +225°F.

EPT - pH Limitations 7-11; Temperature Range -20 to +250°F.



Designed for a variety of applications.

- Hydronic heating & cooling systems
- Domestic water
- Fluid transfer

The advantages you want.

The pump you need.

- Compact design
- Easy installation
- Wide range of standard sizes
- Backed by B&G three-year warranty*

Pump Specifications

A. Manufacturer

Contractor shall furnish and install new, long coupled in-line pumps for chilled water and hot water heating systems as indicated on the drawings. Pumps shall be Series 60 as manufactured by Bell & Gossett under base bid. Alternatives may be submitted as deduct alternates. Pumps shall meet types, sizes, capacities and characteristics as scheduled on the Equipment Schedule drawings.

B. Long Coupled In-line Pump

1. The pumps shall be horizontal, permanently lubricated, specifically designed and guaranteed for quiet operation. Suitable for 225°F operation at 175 psig working pressure. The pump shall be single stage, vertical split-case design, in cast iron bronze fitted (or all bronze) construction. The pump internals shall be capable of being serviced without disturbing piping connections.
2. The pump shall be composed of three separable components: a motor, bearing assembly and pump end (wet end). The motor shaft shall be connected to the pump shaft via a replaceable flexible coupler.
3. The pumps shall have a solid SAE 1144 steel shaft supported by two sealed ball bearings. A non-ferrous shaft sleeve shall be employed to completely cover the wetted area under the seal.
4. Pump shall be equipped with an internally flushed mechanical seal assembly. Seal assembly shall have a brass housing, Buna bellows and seat gasket, stainless steel spring, and be of a carbon ceramic design with the carbon face rotating against a stationary ceramic face.
5. Bearing assembly shaft shall connect to a cast bronze impeller. Impeller shall be both hydraulically and dynamically balanced, keyed to the shaft and secured by a locking cap screw or nut.
6. A flexible-type coupling shall be employed between the pump and motor.
7. Pump should be designed to allow for true back pull-out access to the pump's working components for ease of maintenance.
8. Pump volute shall be of cast iron design for heating systems or cast bronze for domestic water systems. The connection style on cast iron and bronze pumps shall be flanged. Volute shall include gauge ports at nozzles, and vent and drain ports.
9. To ensure alignment, the motor shall be mounted to the bearing assembly via a bolted motor bracket assembly, and a rubber motor mount will be used to assist in aligning the motor shaft with the pump shaft.
10. Motors shall meet scheduled horsepower, speed, voltage and enclosure design. Motors through 1 HP shall be resilient mounted, motors over 1.5 HP shall be rigid mounted. Motors shall have permanently lubricated ball bearings and must be completely maintenance free. Motors shall be non-overloading at any point on the pump curve and shall meet NEMA specifications.
11. Pump shall be of a maintainable design and for ease of maintenance should use machine fit parts, not press fit components.
12. Pump manufacturer shall be ISO-9001 certified. Pump shall be of U.S. manufacturer.
13. Each pump shall be factory tested and name-plated before shipment.
14. Pump shall have a three (3) year warranty from date of installation.*

C. Accessories

Where noted on schedule, an EPT high pH (7-11) seal should be used in lieu of the Buna standard pH (7-9) seal. EPT seals are applicable on systems with up to 250°F maximum water temperatures.

** Warranty coverage is for a period of 36 months from date of manufacture. Consult your local Bell & Gossett representative for warranty details.*

ITT Corporation
8200 N. Austin Avenue
Morton Grove, Illinois 60053
Phone: (847) 966-3700
Fax: (847) 966-9052
www.bellgossett.com



Engineered for life