

# REGULATORS

## 175/153 Series

### Self-Operating Temperature Regulating Valves

Watson McDaniel reserves the right to change the designs and/or materials of its products without notice.  
©2006 Watson McDaniel Company

175 – HEATING  
153 – COOLING



175 / 153  
Screwed  
Connection



175T / 153T\*  
Screwed Connection with  
Temperature-Indicating Dial



175 / 153  
Flanged  
Connection



175 / 153  
Union-end  
Connections

\* "T" – Temperature-Indicating Dial (Must be field set and calibrated to an actual thermometer)

#### TYPICAL APPLICATIONS

The 175 and 153 Series Self-Operating Temperature Regulating Valves require no external power source making them easy to install and maintain. Properly installed, the regulator is capable of maintaining temperatures to within  $\pm 3^{\circ}\text{F}$ .

#### FEATURES

- Hermetically-sealed Bellows, Capillary Tube & Bulb Assembly for extended service life
- Easily adjusted to any point within its temperature range by simply rotating the adjustment control device
- Optional temperature dial on 175T & 153T models indicates temperature of process being controlled
- For both heating and cooling applications
- Reverse-Acting or Direct-Acting Applications
- Large Range of Sizes & Valve Body Types

#### HOW IT WORKS

175/153 Self-Operating Temperature Regulators are actuated by a hermetically-sealed bellows, capillary tube and bulb assembly. The bulb is inserted in the fluid at the point where temperature control is needed. As temperature rises around the bulb, the volatile liquid gas inside the bulb, capillary and bellows expands and transmits a force moving the valve stem downward. Conversely, when the temperature at the bulb decreases, the liquid (or gas) contracts, allowing the regulating spring to compress the bellows and move the valve stem upwards. The regulator can easily be adjusted to any point within its temperature range by simply rotating the adjustment control device.

#### HEATING APPLICATIONS – 175/175T

The direct-acting 175 /175T self-operating temperature regulators should be used in applications that require a rise in temperature to close the valve. These regulators will increase the temperature of a medium (liquid or gas) by remotely sensing the medium's temperature and throttling steam flow to it, bringing it to the desired temperature. Use in:

- Plating or Finishing Tanks
- Hot Water Generators & Storage Tanks
- Heat Exchangers
- Fuel Oil Storage Tanks & Heaters
- Circulating Dryers & Ovens
- Steam Tables
- Open Tank or Kettle Control
- Heating Ducts

#### COOLING APPLICATIONS – 153/153T

The reverse-acting 153/153T self-operating temperature regulators should be used in applications that require a rise in temperature to open the valve. These regulators will reduce the temperature of a medium (liquid or gas) by remotely sensing the medium's temperature and throttling a cooling liquid (normally water) to flow to it, bringing it to the desired temperature. Use in:

- Cooling Ducts
- Engine Jacket Cooling
- Oil Coolers
- Open Cooling Tanks
- Dehumidification

## 175/153 Series

### Self-Operating Temperature Regulating Valves

#### Typical Applications for Temperature Regulators

175T Heating Fuel Oil To Proper Temperature

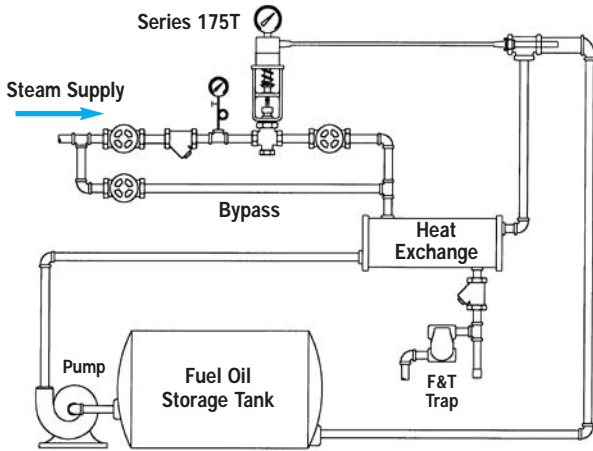

175T Elevating Temperature Of A Plating Or Finishing Tank

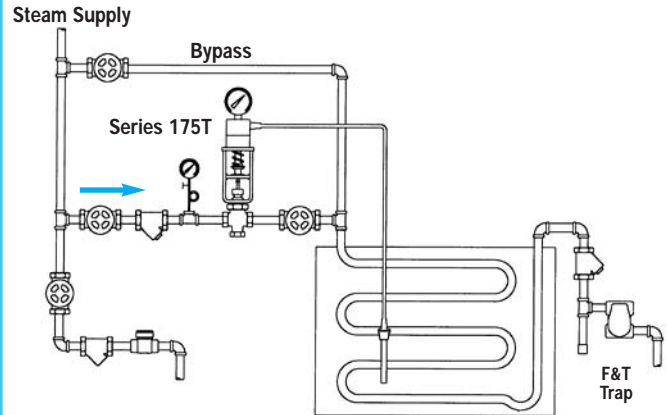

175 Used for Regulating Steam Flow In An Autoclave/Sterilizer

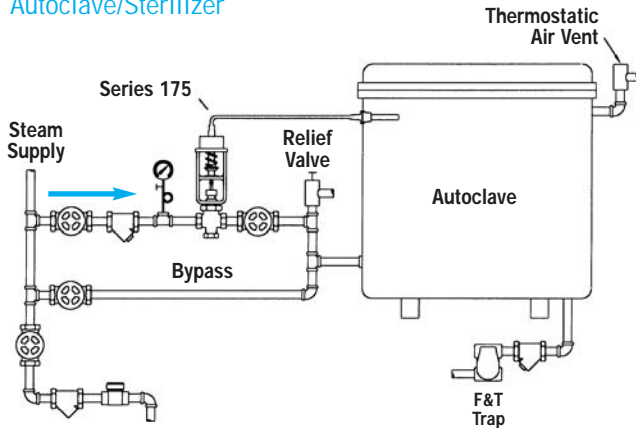

175T Used In A Drying Oven Application

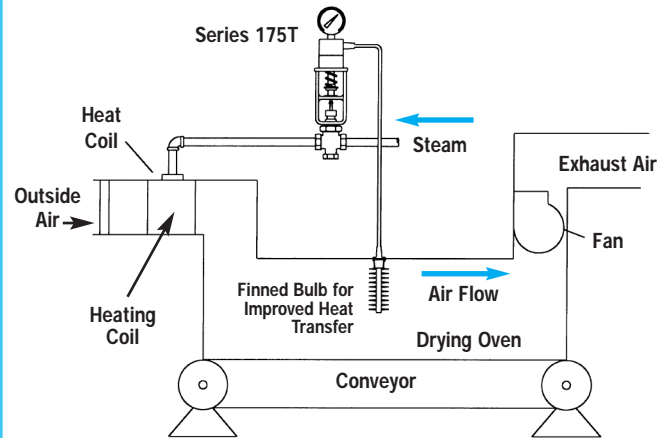

153 Used to Reduce Oil Temperature In A Heat Exchanger

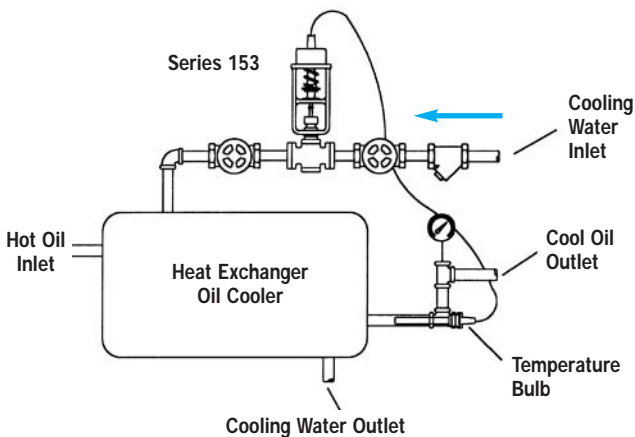

153 Used To Control Water Flow In A Grinding Mill For Temperature Reduction

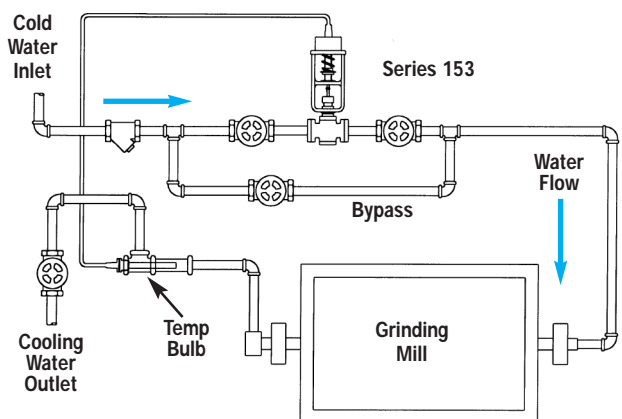

# REGULATORS

## 175/153 Series

### Self-Operating Temperature Regulating Valves

Watson McDaniel reserves the right to change the designs and/or materials of its products without notice.  
©2006 Watson McDaniel Company

#### DIMENSIONS for Thermal Head – inches/pounds

Valve Size	Standard Bulb Range	Bulb Length D	Bulb Diameter E	Bushing Thread F	Capillary Length (ft)	Dry Well or Separable Socket		
						G	H	J
1/2" to 2"	*20-80°	17 <sup>1</sup> / <sub>2</sub>	7/8	1	10	1	18 <sup>1</sup> / <sub>2</sub>	1
	*40-100°	17 <sup>1</sup> / <sub>2</sub>	7/8	1	10	1	18 <sup>1</sup> / <sub>2</sub>	1
	*60-120°	17 <sup>1</sup> / <sub>2</sub>	7/8	1	10	1	18 <sup>1</sup> / <sub>2</sub>	1
	*80-140°	17 <sup>1</sup> / <sub>2</sub>	7/8	1	10	1	18 <sup>1</sup> / <sub>2</sub>	1
	*100-160°	17 <sup>1</sup> / <sub>2</sub>	7/8	1	10	1	18 <sup>1</sup> / <sub>2</sub>	1
	110-170°	10 <sup>1</sup> / <sub>2</sub>	5/8	1	10	1	11 <sup>1</sup> / <sub>2</sub>	3/4
	130-190°	10 <sup>1</sup> / <sub>2</sub>	5/8	1	10	1	11 <sup>1</sup> / <sub>2</sub>	3/4
	150-210°	10 <sup>1</sup> / <sub>2</sub>	5/8	1	10	1	11 <sup>1</sup> / <sub>2</sub>	3/4
2-1/2" to 4"	170-230°	10 <sup>1</sup> / <sub>2</sub>	5/8	1	10	1	11 <sup>1</sup> / <sub>2</sub>	3/4
	190-250°	10 <sup>1</sup> / <sub>2</sub>	5/8	1	10	1	11 <sup>1</sup> / <sub>2</sub>	3/4
	*60-100°	29 <sup>3</sup> / <sub>4</sub>	1 <sup>1</sup> / <sub>8</sub>	1 <sup>1</sup> / <sub>4</sub>	10	1 <sup>1</sup> / <sub>4</sub>	30 <sup>1</sup> / <sub>2</sub>	1 <sup>1</sup> / <sub>4</sub>
	*80-120°	29 <sup>3</sup> / <sub>4</sub>	1 <sup>1</sup> / <sub>8</sub>	1 <sup>1</sup> / <sub>4</sub>	10	1 <sup>1</sup> / <sub>4</sub>	30 <sup>1</sup> / <sub>2</sub>	1 <sup>1</sup> / <sub>4</sub>
	*100-140°	29 <sup>3</sup> / <sub>4</sub>	1 <sup>1</sup> / <sub>8</sub>	1 <sup>1</sup> / <sub>4</sub>	10	1 <sup>1</sup> / <sub>4</sub>	30 <sup>1</sup> / <sub>2</sub>	1 <sup>1</sup> / <sub>4</sub>
	120-160°	17 <sup>1</sup> / <sub>2</sub>	7/8	1	10	1	18 <sup>1</sup> / <sub>2</sub>	1
	140-180°	17 <sup>1</sup> / <sub>2</sub>	7/8	1	10	1	18 <sup>1</sup> / <sub>2</sub>	1
	160-200°	17 <sup>1</sup> / <sub>2</sub>	7/8	1	10	1	18 <sup>1</sup> / <sub>2</sub>	1
4"	180-220°	17 <sup>1</sup> / <sub>2</sub>	7/8	1	10	1	18 <sup>1</sup> / <sub>2</sub>	1
	200-240°	17 <sup>1</sup> / <sub>2</sub>	7/8	1	10	1	18 <sup>1</sup> / <sub>2</sub>	1
	220-260°	17 <sup>1</sup> / <sub>2</sub>	7/8	1	10	1	18 <sup>1</sup> / <sub>2</sub>	1

\*Cross-ambient filled thermal systems: these units are standard on 100° F or less minimum temperature ranges. If the surrounding air temperature (ambient air temperature) is within 20° F of the minimum temperature that the unit will be used at, a special cross-ambient temperature unit is required. Cross-ambient filled bulb lengths are 17<sup>1</sup>/<sub>2</sub>" for 1/2"-2" valves, and a 29<sup>3</sup>/<sub>4</sub>" for 2<sup>1</sup>/<sub>2</sub>"-4" valves.

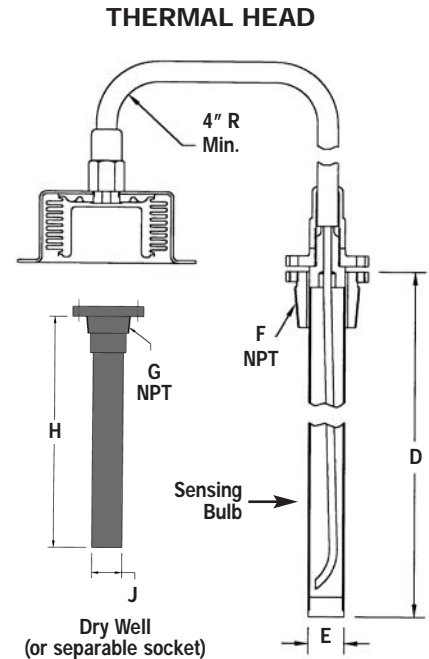

NOTE: Dry well must be filled by installer with oil or grease to help in heat transfer.

#### OPTIONS

Thermal Head Assembly Kits	1/2" - 2"	Model THA THA with Dial Indicator
Special Bulbs, Bushings & Capillary	1/2" - 2"	316L SST Bulb & Bushing with 316 SST Capillary & Armor
		316L SST Bulb (no bushing) with 10-ft. of Plain 316L Capillary (over the rim)
		Finned Copper Bulb for Duct Mount Wall Bracket for Finned Bulb
Additional Capillary in 5-ft. lengths	All Sizes	Standard Capillary - Copper with 316L S Armor
		Stainless Steel Capillary - 316L SST w/316L SST Armor
Separable Wells	All Sizes	Copper Well
		316 SST Well

NOTE: Consult factory for availability of coated bulb, capillary, coated wells or special lengths.

#### FEATURES

- Dial Indicator: The 175T and 153T have a dial indicator on top of the thermal system.
- Capillary Length: Standard capillary length is 10-ft. Additional lengths available in 5-ft. increments. Maximum capillary length is 25-ft.

#### MATERIALS

Head Assembly	Bulb and capillary	Copper
	All other parts	Brass
Dry well (or separable socket)	Bulb	Copper
	All other parts	Brass
Dry well (or separable socket)	Bulb	316 SST
	All other parts	316 SST

#### HOW TO ORDER

Specify: Model THA or  
THA with Dial Indicator

- Temperature Range  
Note: If ambient room temperature is within 20°F of the minimum temperature in any selected bulb range, a special cross-ambient fill must be specified on your order.
- Special Options for Bulbs, Bushings, Capillary and Wells, see Options chart

## 175/153 Series

### Self-Operating Temperature Regulating Valves

Steam flow required through a temperature regulator (lbs/hr) to heat a specified number of gallons of water per hour (gal/hr)

TABLE 1 - Steam Flow Required in Pounds Per Hour (lbs/hr)

Temp Increase (°F)	Gallons of Water per Hour To Be Heated												Temp Increase (°F)
	25	50	100	200	300	500	700	1000	2000	4000	10,000	20,000	
5°	1	2	4	8	12	21	29	41	83	166	415	830	5°
10°	2	4	8	16	25	41	58	83	166	332	830	1660	10°
15°	3	6	12	25	37	62	87	124	249	498	1245	2490	15°
20°	4	8	17	33	50	83	116	166	332	664	1660	3320	20°
25°	5	10	20	42	62	104	145	207	415	830	2075	4150	25°
30°	6	12	25	50	75	124	174	249	498	996	2490	4980	30°
40°	8	16	33	66	100	166	232	332	664	1328	3320	6640	40°
50°	10	21	42	83	124	207	290	415	830	1660	4150	8300	50°
60°	12	25	50	100	149	249	348	498	996	1992	4980	9960	60°
70°	15	29	58	116	174	290	407	581	1162	2324	5810	11,620	70°
80°	17	33	67	133	199	332	465	664	1328	2656	6640	13,280	80°
90°	19	38	75	149	224	373	523	747	1494	2988	7470	14,940	90°
100°	21	42	83	166	249	415	581	830	1660	3320	8300	16,600	100°
115°	24	48	95	191	286	477	668	955	1909	3818	9544	19,088	115°
130°	27	54	108	216	324	539	755	1079	2158	4316	10,790	21,580	130°
145°	30	60	120	241	361	601	842	1200	2400	4812	12,030	24,060	145°
160°	33	66	133	266	398	664	929	1328	2656	5312	13,280	26,560	160°
175°	36	72	145	290	436	726	1017	1452	2900	5810	14,524	29,048	175°
200°	41	83	166	332	498	830	1162	1660	3320	6640	16,600	33,200	200°
225°	47	94	187	374	560	934	1307	1867	3735	7470	18,680	37,360	225°
250°	52	104	207	415	622	1037	1452	2075	4150	8300	20,750	41,500	250°

REGULATORS

**HEATING WATER:** The amount of steam required to heat water can be found using chart above.

*Example:* To heat 1000 gallons per hour of water from 40°F to 140°F (Temp. increase 100°F) requires 830 lbs/hr of steam.

**HEATING FUEL OIL:** The amount of steam required to heat fuel oil is half of that to heat water. Use half the value found in chart above.

*Example:* To heat 1000 gallons per hour of fuel oil from 40°F to 140°F (Temp. increase 100°F) requires 415 lbs/hr of steam.

### CAPACITY CALCULATIONS FOR STEAM LOADS

When BTU Load is Known	Capacity of steam required (lbs/hr)	= $\frac{\text{BTU}}{1000}$
When Square Feet Equivalent Direct Radiation (EDR) is Known	Capacity of steam required (lbs/hr)	= $\frac{\text{Sq ft. of EDR}}{4}$
When Heating Water with Steam	Capacity of steam required (lbs/hr)	= $\frac{\text{GPM} \times \text{Temp Rise } ^\circ\text{F}}{2}$
When Heating Fuel Oil with Steam	Capacity of steam required (lbs/hr)	= $\frac{\text{GPM} \times \text{Temp Rise } ^\circ\text{F}}{4}$
When Heating Air with Steam Coils	Capacity of steam required (lbs/hr)	= $\frac{\text{CFM} \times \text{Temp Rise } ^\circ\text{F}}{900}$

# REGULATORS

## 175 Series

### Self-Operating Temperature Regulating Valves

Watson McDaniel reserves the right to change the designs and/or materials of its products without notice.  
©2006 Watson McDaniel Company

Model	175/175T - HEATING
Service	Water, Steam, Other Liquids
Sizes	1/2", 3/4", 1", 1 1/4", 1 1/2", 2", 2 1/2", 3", 4"
Connections	NPT, 125 Flanged 250 Flanged
Body Material	1/2" - 1 1/2" Bronze 2" - 4" Cast Iron
Seat Material	Stainless Steel
Max. Inlet Pressure	250 PSIG

#### DESIGN PRESSURE/TEMPERATURE RATING - PMA/TMA

NPT	250 PSIG @ 450° F
125# FLG	125 PSIG @ 450° F
250# FLG	250 PSIG @ 450° F

#### FEATURES

- 10-ft. copper capillary with 316 SST armor
- Heavy duty exterior construction
- Bulb and capillary options include 316 stainless steel and Kynar
- Dial thermometer optional for visual temperature readings on model 175T

#### HOW TO ORDER

Specify: • Model - Series 175 (non-indicating)  
Series 175T (dial indicator)

- Size
- Type of connection - NPT, Union or Flanged
- Temperature Range
- Options - See Options chart
- Specify if for Water Service

#### DIMENSIONS - inches/pounds

Size	Max Operating Pressure	A			AA Union Connection	B	C**	Weight (lbs)	Cv
		Threaded NPT	125 Flanged	250 Flanged					
1/2" A*	250	3 1/4			N/A	1 1/2	14 1/4	12	0.9
1/2" B*	200	3 1/4			N/A	1 1/2	14 1/4	12	1.5
1/2"	250	4 1/8			6 1/2	2 3/8	13 1/2	14	3.3
3/4"	250	4 1/8			6 1/2	2 3/8	13 1/2	14	6.5
1"	200	4 1/8			7	2 3/8	13 1/2	14	11.1
1 1/4"	200	4 13/16			7 1/2	3 1/4	14	17	16.5
1 1/2"	200	5 3/16			8	3 1/2	14 1/2	18	23.1
2" NPT	150	9 1/2			N/A	5 3/4	15 1/4	50	34.2
2" FLG	150		10 3/8	10 7/8		5 3/4	15 1/4	80	34.2
2 1/2"	150		10 5/8	11 1/4		7	24	96	49.0
3"	150		10 7/8	11 5/8		8	25	110	70.2
4"	150		12 1/2	13 1/8		8 3/4	26	160	113.0

\* 1/2" A - 1/4" Diameter Internal Port

\* 1/2" B - 3/8" Diameter Internal Port

\*\* Add 6" for Indicating Dial

#### 175 Series Heating Applications

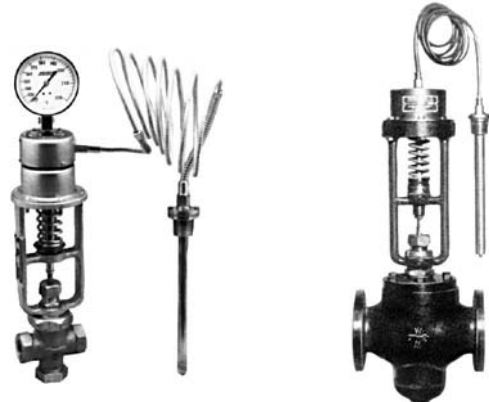

175T  
Screwed with  
Dial Indicator

175  
Flanged,  
Non-Indicating

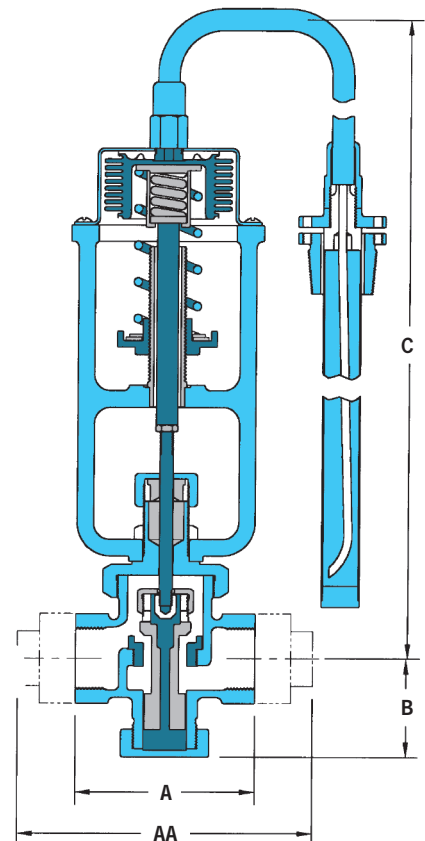

# REGULATORS

## 175 Series

### Self-Operating Temperature Regulating Valves

CAPACITIES – Steam (lbs/hr)											
Pressure (PSIG)	1/2" A	1/2" B	1/2"	3/4"	1"	Size 1 1/4"	1 1/2"	2"	2 1/2"	3"	4"
1	24	43	81	160	275	400	570	840	1,200	1,740	2,800
3	27	48	91	180	310	450	640	950	1,360	1,960	3,150
5	30	54	102	200	345	500	710	1,050	1,520	2,180	3,500
10	37	67	127	250	430	630	900	1,320	1,900	2,720	4,370
15	45	81	153	300	515	760	1,070	1,580	2,280	3,270	5,250
20	52	84	178	350	600	890	1,250	1,850	2,660	3,810	6,120
25	60	108	204	400	692	1,010	1,430	2,120	3,040	4,360	7,000
30	67	121	229	450	775	1,140	1,600	2,380	3,420	4,900	7,870
40	82	150	280	550	950	1,400	1,970	2,900	4,180	5,990	9,620
50	97	177	331	650	1,120	1,650	2,330	3,440	4,940	7,080	11,370
60	112	204	382	750	1,290	1,900	2,700	3,970	5,700	8,170	13,120
70	127	230	433	850	1,470	2,160	3,050	4,500	6,460	9,260	14,870
80	142	258	484	950	1,640	2,410	3,400	5,000	7,220	10,350	16,620
90	157	285	535	1,050	1,810	2,670	3,770	5,560	7,980	11,440	18,370
100	172	312	586	1,150	1,980	2,930	4,130	6,090	8,740	12,530	20,120
125	210	378	714	1,400	2,420	3,560	5,030	7,410	10,640	15,260	24,500
150	245	445	841	1,650	2,850	4,200	5,930	8,740	12,540	18,000	28,800
175	285	513	969	1,900	3,280	4,850	6,830				
200	322	580	1,096	2,150	3,710	5,470	7,730				
250	395	711	1,350	2,650							

CAPACITIES – Water (gpm)									
Differential Pressure	1/2"	3/4"	1"	1 1/4"	Size 1 1/2"	2"	2 1/2"	3"	4"
1	3	5	10	14	20	29	42	60	96
3	4	9	16	23	34	49	71	102	163
5	6	12	21	32	46	66	96	138	220
10	9	17	30	44	64	92	134	192	307
15	11	21	37	54	78	113	163	234	374
20	12	24	42	63	90	130	189	270	432
25	14	27	47	70	100	145	210	300	480
30	15	30	52	77	111	160	231	330	528
40	17	34	59	88	127	182	264	378	604
50	19	39	67	99	143	206	298	426	681
60	21	43	74	109	157	229	327	468	748
70	23	46	79	117	169	243	352	504	806
80	25	49	84	124	180	258	373	534	854
90	26	52	90	133	192	275	399	570	912
100	28	55	95	140	202	290	420	600	960
125	31	61	106	156	226	324	470	672	1070
150	34	67	116	170	246	353	512	732	1170
175	37	72	125	184	266				
200	40	78	135	200	288				

Note: To determine the differential pressure across the Series 175 subtract the down stream pressure from the supply pressure.

REGULATORS

# REGULATORS

## 153 Series

### Self-Operating Temperature Regulating Valves

Watson McDaniel reserves the right to change the designs and/or materials of its products without notice.  
©2006 Watson McDaniel Company

Model	153/153T - COOLING
Service	Water, Other Liquids
Sizes	1/2", 3/4", 1", 1 1/4", 1 1/2", 2", 3", 4"
Connections	NPT, 125 # & 250# Flanged
Body Material	1/2" - 1 1/2" Bronze 2" - 4" Cast Iron
Seat Material	Stainless Steel
Max. Inlet Pressure	250 PSIG

#### DESIGN PRESSURE/TEMPERATURE RATING - PMA/TMA

NPT	250 PSIG @ 450° F
125# FLG	125 PSIG @ 450° F
250# FLG	250 PSIG @ 450° F

#### FEATURES

- 10 ft. copper capillary with 316 SST armor
- Heavy duty exterior construction
- Bulb and capillary options include 316 stainless steel and Kynar
- Dial thermometer optional for visual temperature readings on Model 153T

#### DIMENSIONS & WEIGHTS - inches/pounds

Size	Max Operating Pressure	A			AA Union Connection	B	C**	Weight (lbs)	Cv Flow Factor
		Threaded NPT	125 Flanged	250 Flanged					
1/2"	125	4 1/8			6 1/2	2 3/8	14	12	2.4
3/4"	125	4 1/8			6 1/2	2 3/8	14	12	2.8
1"	100	4 1/8			7	2 3/8	14	13	5.5
1 1/4"	70	5			7 1/2	3 1/8	14 1/2	15	9.5
1 1/2"	70	5 1/4			8	3 3/8	14 1/2	16	14.0
*2" NPT	150	7 3/8			N/A	3 3/4	16 1/2	40	30.0
*2" FLG	150		7 1/8	7 3/4		3	15 1/2	46	30.0
3"	150		9	9 3/4		5 1/2	32 1/2	125	62.0
4"	150		10 1/8	10 3/4		6 1/2	34 1/2	185	105.0

\* 2" NPT - 4" Flanged are double-seated

\*\* 1/2" - 2" Add 6" for Indicating Dial

#### HOW TO ORDER

Specify:

- Model - Series 153 (non-indicating)  
Series 153T (dial indicator)
- Size
- Type of connection - NPT, Union or Flanged
- Temperature Range
- Options - See Options chart

#### 153 Series Cooling Applications



153 Flanged Connection



153 Union-end Connections

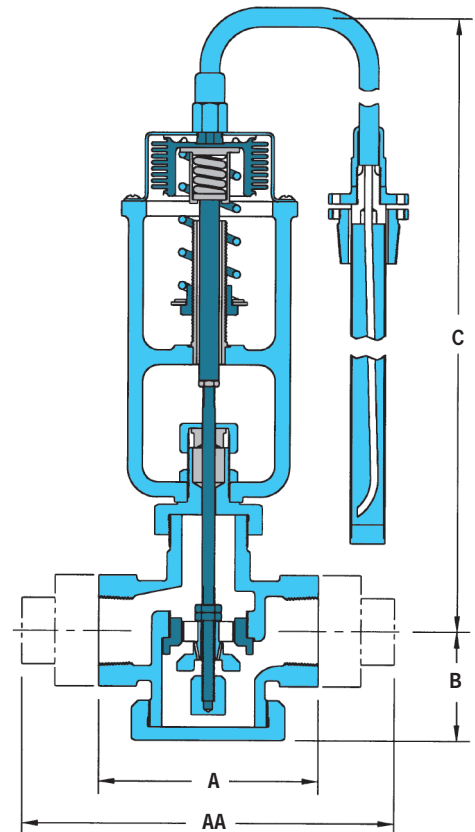

# REGULATORS

## 153 Series

### Self-Operating Temperature Regulating Valves

#### CAPACITIES – Water (gpm)

Differential Pressure	Size							
	1/2"	3/4"	1"	1 1/4"	1 1/2"	2"	3"	4"
1	2	3	6	10	14	30	62	105
3	4	5	9	16	23	50	105	178
5	5	6	12	21	32	69	142	241
10	7	9	17	30	44	96	198	336
15	9	11	21	37	54	110	241	409
20	10	12	24	42	63	135	279	472
25	12	14	27	47	70	150	310	525
30	13	15	30	52	77	165	341	577
40	15	17	34	59	87	189	390	661
50	17	19	39	67	99	213	440	743
60	18	21	43	74	109	234	483	819
70	20	23	45	78	114	252	520	882
80	21	25	50			267	551	930
90	23	26	51			285	589	997
100	24	28	55			300	620	1,050
125	27	31				336	694	1,176

Note: To determine the differential pressure across the Series 153 subtract the down stream pressure from the supply pressure.