

LIQUID DRAINERS

WLD1703S

Thermodynamic Drain Trap

Watson McDaniel reserves the right to change the designs and/or materials of its products without notice.
©2006 Watson McDaniel Company

Model	WLD1703S
Sizes	1/2"
Connections	NPT
Body Material	Stainless Steel
Options	Blowdown Valve
PMO Max. Operating Pressure	250 PSIG
TMO Max. Operating Temperature	750°F
PMA Max. Allowable Pressure	915 PSIG up to 250°F
TMA Max. Allowable Temperature	610°F @ 750 PSIG



1703SB
with Strainer &
Blowdown

1703S
with Strainer
1703SB
with Strainer
& Blowdown

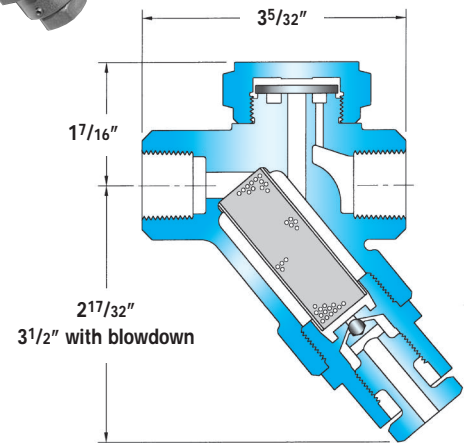

TYPICAL APPLICATION

The WLD1703S is used on air and gas applications as drip traps on system mains and other piping runs. These drain traps are ideal for outdoor applications where units are subject to freezing.

HOW IT WORKS

The thermodynamic liquid drain trap has a cyclic on/off operation with a disc that is pushed open when condensate is present and pulled closed when the gas tries to escape.

FEATURES

- Rugged, stainless steel body and hardened seat
- Handles a wide range of pressures up to 250 PSIG
- Works in any position (horizontal preferable)
- Integral strainer with blowdown option
- Three-holed balanced discharge
- Freeze proof in vertical orientation flow down position

SAMPLE SPECIFICATION

Drain Trap shall be thermodynamic disc type with an all stainless steel construction. Body shall have a built-in strainer with optional blowdown valve. Integral seat design and disc to be hardened for long service life. Unit shall be capable of installation in any orientation and self-draining when mounted vertically with flow down.

INSTALLATION

Drain Trap can be installed in any position, however, horizontal is preferred. Installation should include isolation valves for maintenance purposes.

MAINTENANCE

Dirt is the most common cause of premature failure. The strainer should be periodically cleaned. For full maintenance details see Installation and Maintenance Manual.

OPTIONS

Blowdown valve for easy maintenance.

MATERIALS

Body	Stainless Steel, AISI 420F
Disc	Stainless Steel, AISI 420
Cap	Stainless Steel, AISI 416
Strainer Screen	Stainless Steel, AISI 304
Blowdown Valve*	Stainless Steel, AISI 303

*WLD1703SB model only.

COLD WATER CAPACITIES – (lbs/hr)

Model	Size	Differential Pressure (PSI)											
		2	5	10	25	50	80	100	125	150	180	200	250
WLD1703S	1/2"	90	130	190	300	425	530	600	670	715	790	835	955
WLD1703SB	1/2"	90	130	190	300	425	530	600	670	715	790	835	955

Note: Maximum back pressure not to exceed 80% of inlet pressure.

To determine gallons per minute of flow divide values in chart by 500.

Example: 600 lbs/hr = 600 ÷ 500 = 1.2 gpm