

FRESH-AIRE UVTM

COMMERCIAL SERIES

TIGHT-FIT KIT

Patent Pending

If a light won't fit ...you need the kit!

FEATURES

- Installs in the tightest spaces such as PTACs and Fan Coil Units
- Weather resistant remote mountable UV lamps with magnetic mounting shield
- 18-32 or 110-277 VAC power supply with flexible mounting options
- 1 year guaranteed lamp life
- Five year power supply Warranty

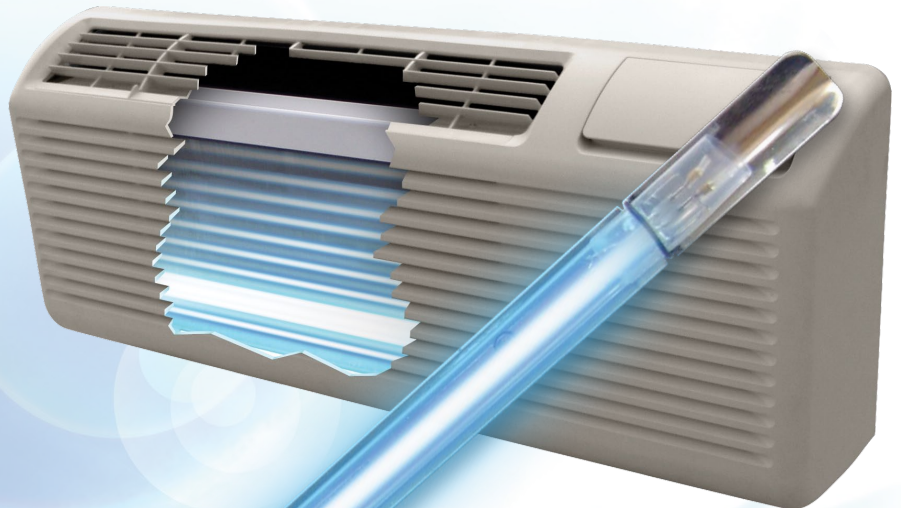

**Extended Range
18-32 or 110-277 VAC
Power Supply
Options!**

BENEFITS

- Kills airborne mold, bacteria, and viruses
- Provides a healthier living environment for your family
- Kills mold, bacteria, and viruses where they lurk
- Reduces system maintenance
- Reduces household odors

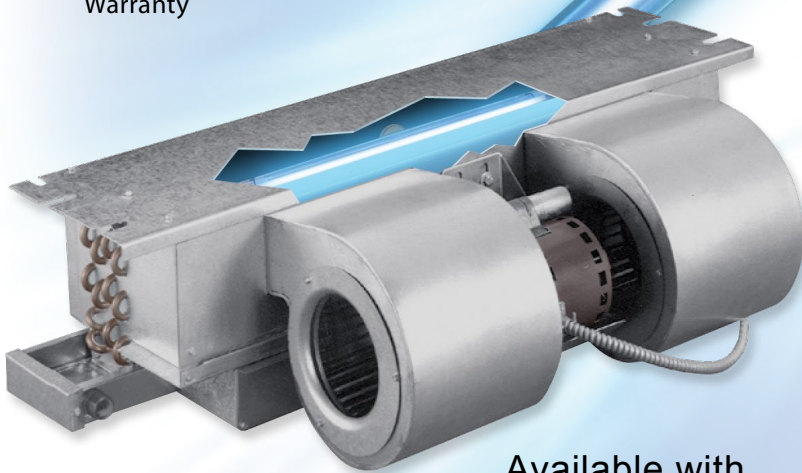

Available with

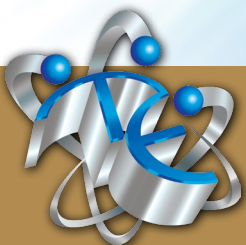

A **FRESH-AIRETM** product manufactured by:
Triatomic Environmental, Inc.
sales@freshaireuv.com
800-741-1195



FRESH-AIRE UV™ COMMERCIAL SERIES TIGHT-FIT KIT

TIGHT-FIT KIT UV™

An ideal kit for installation into many of the fan coil units and PTACs found on the market today. The kit provides a means for locating the UV light within these units for optimum UV exposure particularly where space is limited.



TIGHT-FIT KIT UV™

installed in PTAC unit

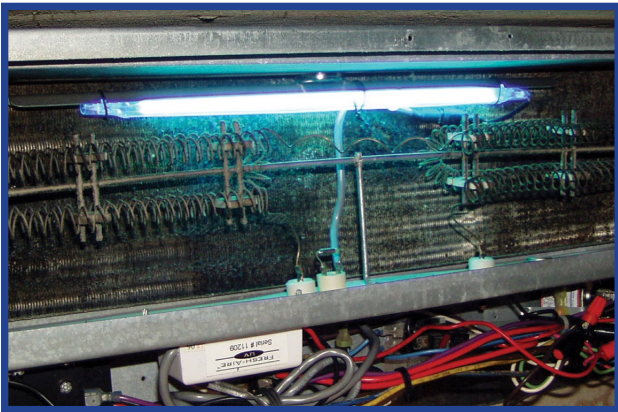

TIGHT-FIT KIT UV™

installed in fan coil unit

Available From:

TIGHT-FIT KIT UV™ Specs

Part # TUV-TFK-ER

Low Voltage 18-32 VAC

Part # TUV-TFK-ER-2

Low Voltage 18-32 VAC with 2 Year Lamp

Part # TUV-TFK-ER-OS

Low Voltage 18-32 VAC with
Odor Sanitizing Technology

Part # TUV-TFK-ER-2-OS

Low Voltage 18-32 VAC with
2 Year Lamp and Odor Sanitizing Technology

Part # TUV-TFK-ST

Line Voltage 120 - 227 VAC

Part # TUV-TFK-ST-2

Line Voltage 120 - 227 VAC with 2 Year Lamp

Part # TUV-TFK-ST-OS

2 Year Lamp and Odor Sanitizing Technology

Part # TUV-TFK-ST-2-OS

Line Voltage 120 - 227 VAC with
2 Year Lamp and Odor Sanitizing Technology

Common Specs

Dimensions	Lamp: 15"L x 0.74" Dia. Power Supply: 4.2"L x 1.8" W x 1"D
Weight	Weight - 1 lb.
Kits Include	Power Supply, 6' Lamp Cable, UV Lamp, Lamp Mounting Brackets, Magnetic Mounting Hardware, Panel Indicator
Warranty	Lamps 1 Year Power Supply 5 Years

Standard UV Lamp

Spectrum	100% 254 NM Germicidal UVC
Lamp Type	Unshielded Quartz Hot Filament
Warranty	1 Year

2 Year UV Lamp

Spectrum	100% 254 NM Germicidal UVC
Lamp Type	Shielded Quartz Hot Filament
Warranty	2 Years

Standard UV Lamp with Odor Sanitizing Option

Spectrum	90% Standard 254 NM Germicidal UVC
Lamp Type	10% 185 NM Odor Oxidation Unshielded Quartz Hot Filament
Warranty	Warranty 1 Year

2 Year UV Lamp with Odor Sanitizing Option

Spectrum	90% Standard 254 NM Germicidal UVC
Lamp Type	10% 185 NM Odor Oxidation Shielded Quartz Hot Filament
Warranty	Warranty 2 Years