

FRESH-AIRE UVTM

COMMERCIAL SERIES

PANEL MOUNT SYSTEM

Panel Mount System

Panel Mount System: Easy, Flexible Installation With Advanced Multi-Voltage Water Resistant Power Supply Featuring the Triatomic Lifetime Power Supply Warranty. The Panel Mount Allows Installations in the Most Difficult, Hard To Reach Areas By Allowing Access to the Coil From the Outside of the System. This System Effectively Kills Mold, Bacteria, and Viruses in HVAC Equipment. You Will Save Energy By Keeping The System Cleaner, Lowering Maintenance Costs and Reducing Chemical Exposure to Maintenance Workers.

FEATURES

- High Quality Water-Resistant Shielded Lamps
- Multi-Voltage Water-Resistant Power Supply
- Easy, Flexible Installation – Allows Installation In the Tightest of Locations.
- Triatomic Lifetime Power Supply Warranty
- Easy, flexible installation

BENEFITS

- Kills Mold, Bacteria, and Viruses in the HVAC System
- Saves energy by Keeping Components Cleaner
- Lowers maintenance costs – Reduced Required cleanings
- Reduces worker exposure to Dangerous Chemicals
- Cost Effective

Shielded 2 year water-resistant UV lamp



External installation up to 4' x 4' coils.



Lifetime multi-voltage water-resistant power supply

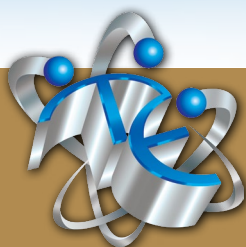

A **FRESH-AIRETM** product manufactured by:
Triatomic Environmental, Inc.
sales@freshaireuv.com
800-741-1195



FRESH-AIRE UVTM

COMMERCIAL SERIES

PANEL MOUNT SYSTEM

Panel Mount Technical Drawings

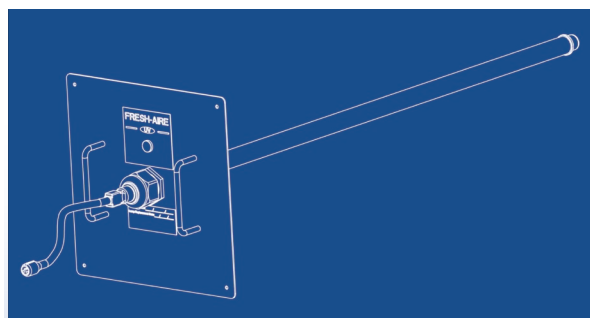
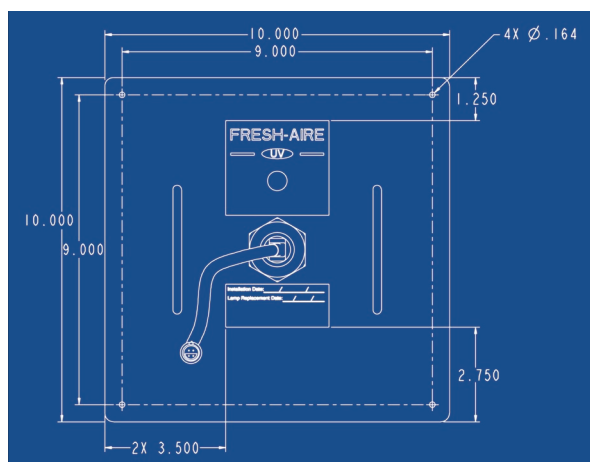
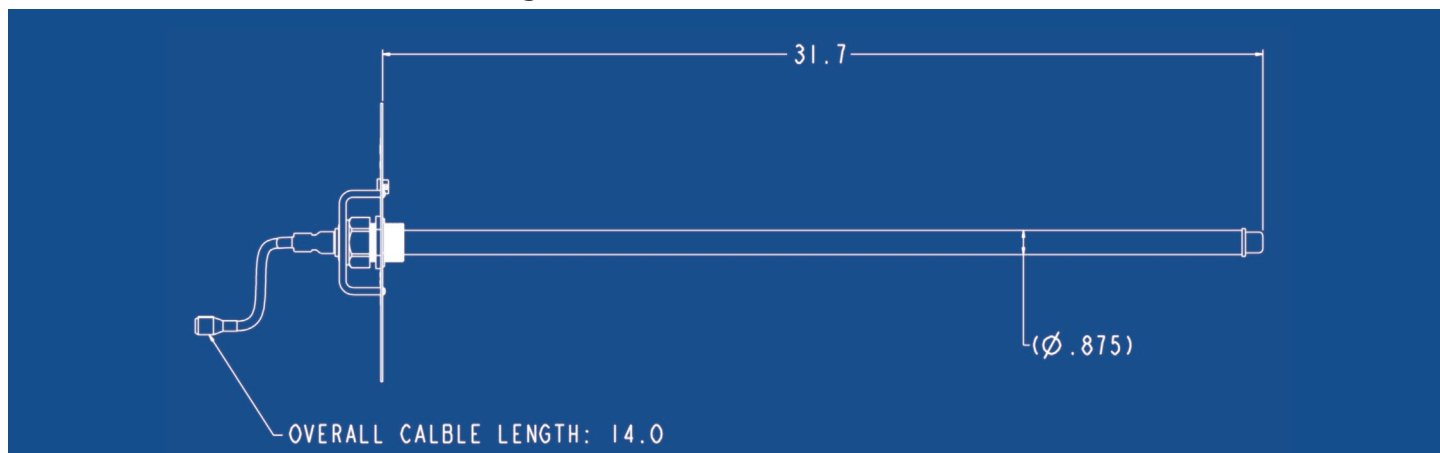

Panel Mount Specifications

	TUVC-200S-P (single) TUVC-200D-P (double)	TUVC-200T-P (triple) TUVC-200Q-P (quad)
Lamp configuration	1 (S), 2 (D), 3 (T), 4 (Q)	
Dimensions	Power supply: single-dual 9"L x 3.75"W x 2.5"H Power supply: triple-quad 13"L x 3.75"W x 2.5"H Panel -10"L x 10"W x 2.5"D Lamp - 32"L x 0.875 Dia.	
Weight	6 Lbs.	
Electrical	Auto switching multi-voltage 120 - 277 VAC, 0.51-0.22 Amps	
Power supply kits include	Panel mount kit: Remote power supply, 6' lamp cable, 6' power cord, UV lamp, panel mounting brackets, mounting hardware and panel indicator	
Lamp type	Shielded quartz hot filament type w/ filament guard	
Lamp output	140 mw/cm ² @ 1 meter 2 Years	
Warranty	2 Years lamp(s) Lifetime power supply	