

Test Plugs

Gauge Adaptor

Description & Features:

- Facilitates quick pressure and temperature readings at recommended test points within process

Applications:

- Mainly used in heating, ventilation and air conditioning industries

| Specifications | |
|-------------------------|----------------------|
| Material/Body | Brass |
| Diaphragm/Core | EPDM |
| Temperature Rating | 350°F (176°C) |
| Maximum Pressure Rating | 1,000 psi (6895 kPa) |
| Connection | 1/4" NPT or 1/2" NPT |

Order Codes (products in bold are normally in stock)

| Brass Test Plug | |
|--------------------------|---------------|
| 1/4" NPT Connection Male | STP001 |
| 1/2" NPT Connection Male | STP002 |

| Gauge Adaptor | |
|---------------------------------|---------------|
| 2.75 OAL x 1.75" x 0.125" probe | STP003 |
| 2.25 OAL x 1.75" x 0.125" probe | STP004 |

Note: Other sizes and materials available upon request

STP Test Plug

Gauge Adaptor 2.25"

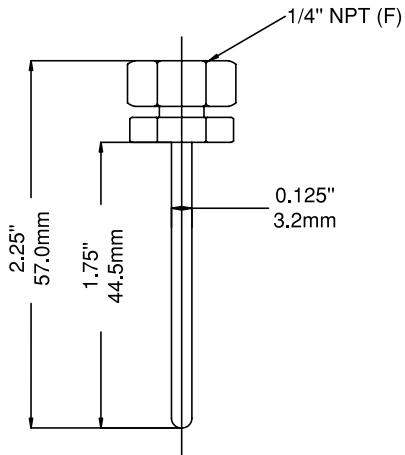

Gauge Adaptor 2.75"

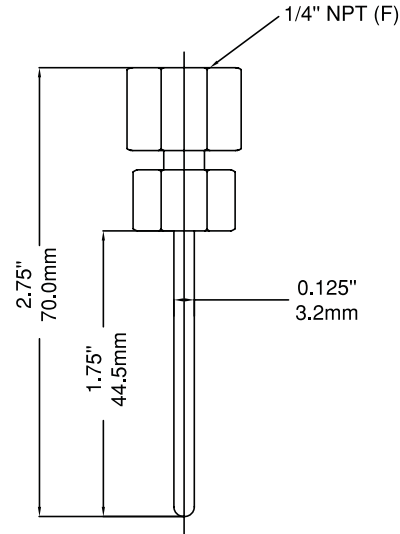

0.25" Test Plug

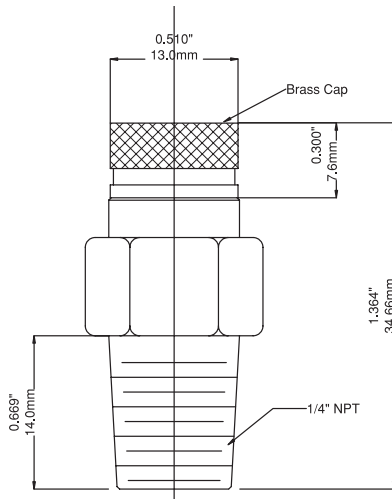

0.5" Test Plug

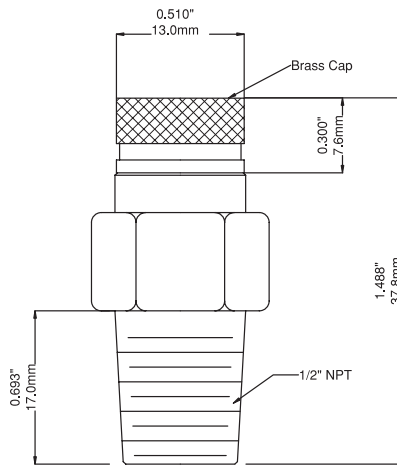

Series Number (for custom, non-standard product)

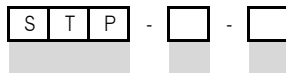

SERIES

CONNECTION SIZE

1/4"

3/8"

1/2"

CONNECTION THREAD

NPT

BSP

BSPT

4

3

2

N

B

T