



Description & Features:

- Designed for use with all 9" (228mm) industrial thermometers to create a "sealed system"
- Allows the easy replacement of thermometers without the need to shut down or drain the system
- CAN/CGSB-14.4-M88 Compliant
- CRN registered
- 1 year warranty

Applications:

- HVAC, pipes, chill water and hot water lines

Specifications	
Material	Brass, AISI 304 SS, AISI 316 SS
Bore Diameter	7/16" tapered
Form	Stepped standard, straight available
Thermometer Connection	1 1/4" UNF
Process Connection	3/4" NPT male standard

Order Codes (products in bold are normally in stock)

Stem Length	Overall Length	Material	Insertion Length	Lagging Extension	1/2" NPT Connection	3/4" NPT Connection
					Code	
3.5" Without Lagging	4.25" (108mm)	Brass	2.5" (63mm)	-	-	TIW01
	4.25" (108mm)	304 SS	2.5" (63mm)	-	-	TIW01-1
	4.25" (108mm)	316 SS	2.5" (63mm)	-	-	TIW01-2
3.5" With Lagging	4.25" (108mm)	Brass	1 3/4" (44mm)	1" (25mm)	TIW02	TIW03
	4.25" (108mm)	304 SS	1 3/4" (44mm)	1" (25mm)	TIW02-1	TIW03-1
	4.25" (108mm)	316 SS	1 3/4" (44mm)	1" (25mm)	TIW02-2	TIW03-2
6" Without Lagging	6 3/4" (172mm)	Brass	5" (127mm)	-	-	TIW04
	6 3/4" (172mm)	304 SS	5" (127mm)	-	-	TIW04-1
	6 3/4" (172mm)	316 SS	5" (127mm)	-	-	TIW04-2
6" With Lagging	6 3/4" (172mm)	Brass	2.5" (63mm)	2.5" (63mm)	-	TIW07
	6 3/4" (172mm)	304 SS	2.5" (63mm)	2.5" (63mm)	-	TIW07-1
	6 3/4" (172mm)	316 SS	2.5" (63mm)	2.5" (63mm)	-	TIW07-2

Option suffix for above order codes only:

W61 = Brass cap and chain (1.25" UNF)

W61-1 = SS cap and chain (1.25" UNF)

Other materials such as Monel®, Inconel®, Hastelloy® C and Titanium are available upon request

Longer thermowells available upon request

Other thread sizes available upon request

3.5" Stem Without Lagging

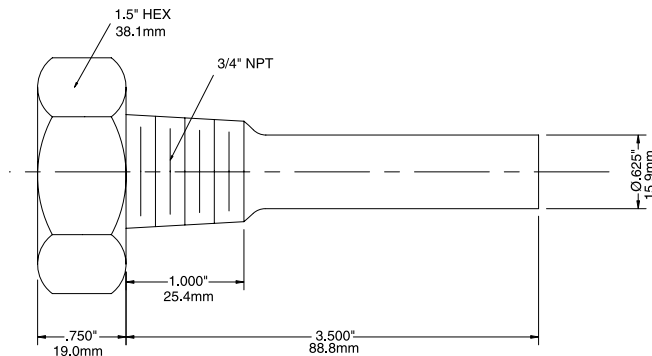

Hastelloy® is a registered trademark of Haynes International, Inc.

Inconel® is a registered trademark of Special Metals Corporation

Monel® is a registered trademark of Inco Alloys International

3.5" Stem With Lagging

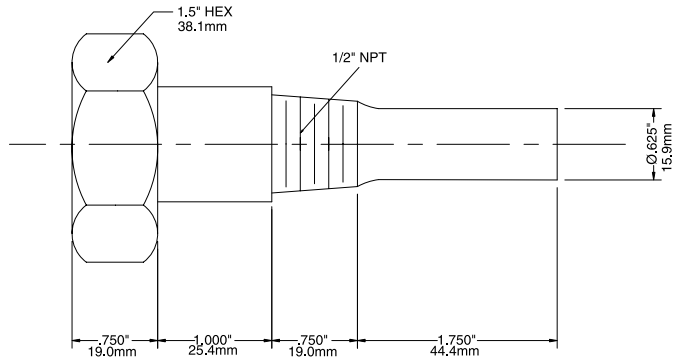

6" Stem Without Lagging

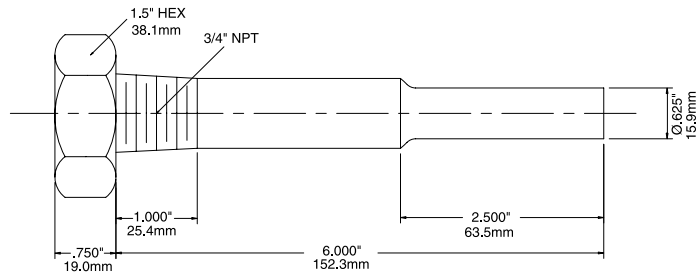

6" Stem With Lagging

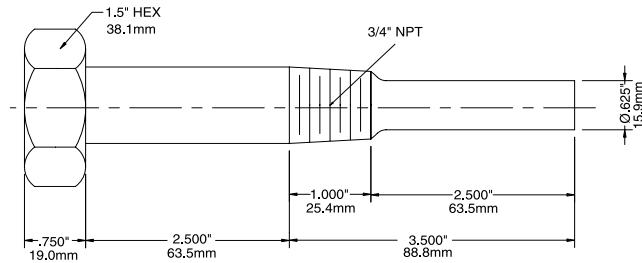

Series Number (for custom, non-standard product)



SERIES

MATERIAL

304SS

2

316SS

5

Brass

B

STEM LENGTH

3.5"

0 3 5

6"

0 6 0

Others (in inches X10)

X X X

PROCESS THREAD SIZE

3/4"

3

1"

1

Special

Z

PROCESS THREAD TYPE

NPT

N

BSP

B

BSPT

T