

H Series Canned Sealless Centrifugal



- Capacities to 2100 GPM
- Heads to over 410 Feet
- Temperatures from -95°F to 750°F



MTH PUMPS

Canned Sealless Centrifugal Pumps

MTH H Series

Sealless Canned Motor Pumps are leak proof and explosion proof because the shaft is located completely inside the pump and there are no mechanical shaft seals that can degrade and leak during operation. True secondary containment design makes it virtually impossible for the process liquid to leak to the environment in the event of a containment failure or pump malfunction.

No External Lubrication

Sealless Canned Motor Pumps do not contaminate atmosphere sensitive fluids by absorbing moisture from the air through external lubrication ports. Lubrication is provided by the pumping fluid during normal operation.

Compact Design

Since Sealless Canned Motor Pumps integrate the motor and pump in one housing, the size is very compact, often half that of other pumps. Savings in both installation costs and floor space are achievable with these units.

Easy Maintenance

Sealless Canned Motor Pumps

require very little maintenance.

Simply change the bearings during annual maintenance checks or when the bearing monitor indicates. These units are easily maintained with relatively unskilled labor.

Low Noise & Vibration

Because these units have no motor fans or ball bearings, and the shaft is completely enclosed, Sealless Canned Motor Pumps have a very low noise output (below 60dBA) and very little vibration.

Bearing Monitor Features

MTH Bearing Monitors take the guess work out of operating a canned motor pump. They continuously monitor the direction of rotation and critical running clearances between the stator and the rotor.

This bearing monitor system not only monitors the running clearance but also indicates bearing condition. This allows the operator to plan in advance for pump maintenance.

The bearing monitor operates on the principle of induced voltage. A magnetic field is created in the monitor coils by the current flowing

through the stator winding. When the rotor is perfectly centered in the stator, the magnetic fields are essentially concentric and balanced. When bearing wear or unequal running clearance occurs, and the rotor drifts off center, the flux created by the imbalance in the magnetic fields induces a voltage in the monitor coils. This voltage is converted and displayed on the monitor's meter as an indication of bearing condition.

Each MTH H Series pump is equipped with a bearing monitor. The meter is mounted on the pump's terminal box as standard, but is also available in a remote panel mount package by customer request.



Bearing wear indicator and rotation detector

Materials

Part	304 Stainless Steel	316 Stainless Steel	316L Stainless Steel	Alloy 20	Hastelloy® C
Pump Casing	304 SS	316 SS	316L SS	Alloy 20	Hastelloy® C
Impeller	304 SS	316 SS	316L SS	Alloy 20	Hastelloy® C
Shaft	304 SS	316 SS	316L SS	Alloy 20	Hastelloy® C
Liner	316L SS	316L SS	316L SS	Hastelloy® C	Hastelloy® C
Sleeves / Thrust Washers	304 SS w/M16C* Coating	316 SS w/M16C* Coating	316L SS w/M16C* Coating	Alloy 20 w/ST#1** Coating	Hastelloy® C
Bearings	Carbon Graphite	Carbon Graphite	Carbon Graphite	Carbon Graphite	Carbon Graphite
Gaskets	Compressed Fiber Sheet	Compressed Fiber Sheet	Compressed Fiber Sheet	Teflon®	Teflon®

Note: Individual component materials are often changed to suit the individual application requirements and provide the most reliable and economical operating life.

* M16C is a Nickel / Chromium flame sprayed hard coating

** ST#1 is Stellite® 1 which is a Cobalt / Chromium / Tungsten flame sprayed hard coating

Limitations

Discharge Pressure	425 PSI		
Speed (Max)	3600 RPM		
Max. Viscosity	100 CP		
Min. Viscosity	0.2 CP		
Temperature			
HCM & HHP Series	30°F to 750°F		
All other H Series	-95°F to 265°F		
Horsepower (Max. by Series*)			
HBT	75HP	HRC	25HP
HCM	150HP	HAS	10HP
HHP	20HP	HAR	4HP
HHJ	40HP	HSP	15HP
HSS/HSJ	50HP		

*Consult Factory for Higher Horsepower

H Series Sealless Centrifugal Pumps



HBT Series

These basic type pumps are designed to prevent any leakage or contamination during chemical or sanitary processes.

Applications include: solvents pumping, oil refineries, reactors, plating systems, and medical plants.

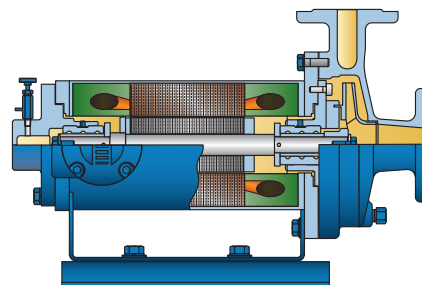

HCM Series

These high temperature chilled motor pumps utilize a tight shaft restriction, an auxiliary impeller, and a water cooled heat exchanger jacket to isolate the high temperature process fluid from the chilled motor end. Secondary cooling water supply required.

Applications include: Process temperatures from 265° - 750°F for medium heating oil, petroleum, heat transfer oils, petrochemical synthesis process, and polymerization process.

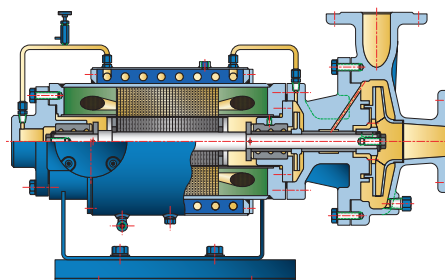

HHP Series

High temperature heat proof pumps are designed to save energy by using a thermally resistant, inorganic substance as a motor winding insulator. With this additional insulation, the motor windings do not require a secondary cooling system and can operate safely at the process fluid temperature.

Applications include: Process temperatures from 265° to 750°F for heat transfer oils, petrochemical synthesis process, polymerization process.

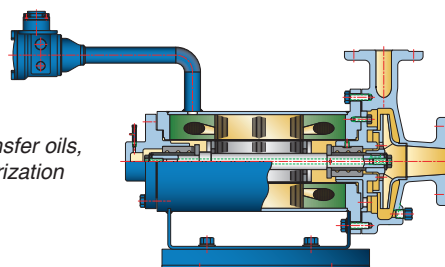

HHJ Series

These pumps are designed to prevent the danger of solidification which is normally found during the transfer of high melting point liquids.

This model helps retain the necessary fluid temperature to maintain pumping action by incorporating a high temperature heating jacket through which steam or hot water is circulated.

Applications include: caprolactam, carboxylic acid, fatty oils, caustic soda

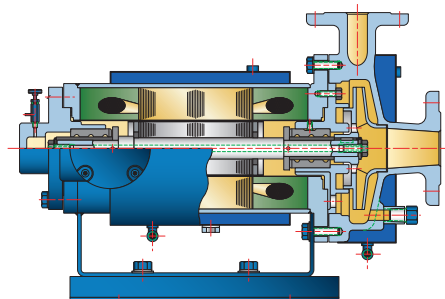

Sealless Centrifugal Pumps



HRC Series

Reverse circulation pumps are designed to minimize the cavitation effects which occur during the transfer of saturated vapor pressure liquids, such as liquefied gasses by the pressurization of the inner structure. Vapor build-up in the pump and motor is flushed by circulating a small constant stream of process fluid through the motor in a reverse direction back to the source tank.

Applications include: ammonia, freon, LPG, and LNG.

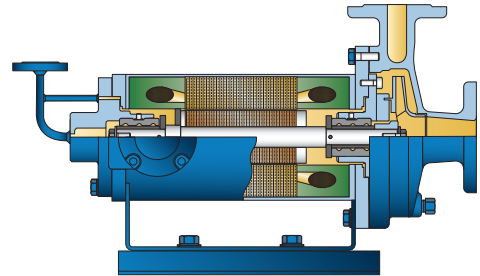

HAS ■ HAR Series

Low NPSH characteristics are required for absorption chiller/heater pumps since the refrigerator operates under a high vacuum state while circulating both absorption solution (HAS Series) and absorption refrigeration medium (HAR Series). A low acceleration inducer is used minimize NPSH requirements.

Applications include: LiBr, H₂O

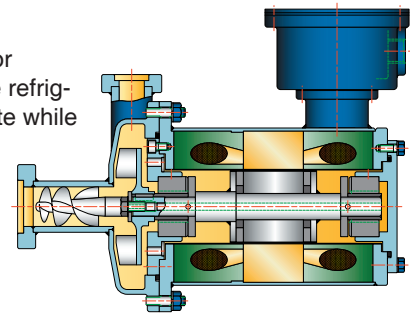

HSP Series

These self-priming pumps are designed for the transfer of liquids which are below the level of the pump. The casing has a specially structured chamber to separate the air from the fluid that is being drawn from the suction pipe. The suction lifts liquids with a specific gravity of 1.0 up to 20 feet.

Applications include: solvent, toluene, benzene, and EG+waste water.

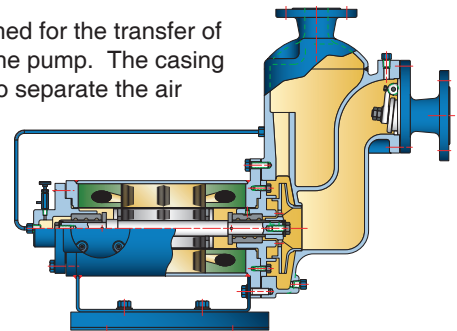

HSS ■ HSJ Series

Vertical slurry pumps are designed to prevent bearing damage due to slurries in the liquid. A mechanical seal installed between the pump and the motor provides physical separation between the slurry and the motor bearings, while an auxiliary cooling system keeps the motor cool.

The HSJ Series pumps can also be used to transfer high melting point liquids with the addition of an optional pump end heating jacket.

Applications include: CEG, TEG+slurry, H₂O+TiO₂, Lactam+TiO₂, and TiO₂+EG.

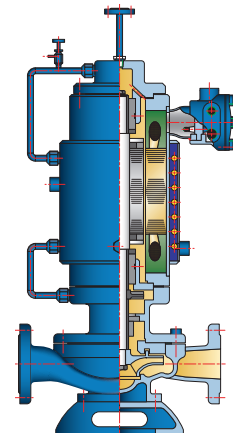

H Series Optional Features

Primary Metallurgy

304, 316, and 316L Stainless Steel are stock materials with Hastelloy® B or C, Monel®, and Alloy 20 available by special order. Consult factory for availability of other materials.

Bearing Materials

Carbon graphite sleeve bearings are standard with Antimony Impregnated Carbon Graphite for high temperature resistance, Silicon Carbide for abrasive fluids, and Glass-filled Teflon® for enhanced chemical resistance to highly corrosive fluids.

Gasket Materials

Compressed fiber sheet gaskets are standard, with Teflon® as an option for high corrosives, and a vortex spiral wound metal gasket for high temperature applications over 400° F.

Low NPSH Inducer

Many pump casings are available in an optional low acceleration screw inducer design to lower NPSH requirements for pumping fluids in a low vapor pressure state (near boiling or prone to flashing to a gaseous state easily).

Reverse Circulation Degassing Line

An optional reverse circulation motor

degassing line is available in the HRC Series to flush gasses that may buildup in the pump or motor during operation or at cycle off times. This reverse circulation line is invaluable in keeping the bearings well lubricated when pumping low vapor pressure or high gas content fluids.

Heating/Cooling Jacket

For materials that require constant heating above ambient temperatures to maintain a liquid state, a heating jacket can be provided around the motor and pump casing to run steam, hot water, or heat transfer fluids to maintain a liquid state suitable for efficient pumping. This option is found in the HHJ and HSJ Series. Likewise, a motor cooling jacket with heat exchanger, recirculation impeller, and temperature isolation adapter may be added to chill the canned motor to its optimal operating temperature and isolate it from pumpage which may exceed the normal 265° F maximum of the H Series, up to 750° F.

This option is found in the HCM Series.

Slurry Barrier

When pumping slurries, additional isolation is required to protect the sleeve bearings found in the H Series

canned pumps. In the case of the HSS and HSJ Series, a special mechanical seal provides a slurry barrier that prevents contamination of the clean motor cooling and bearing lubrication fluid. An external temperature controlled fluid system is required to maintain motor winding temperature below its design maximum of 265° F.

Self-Priming Casings

For high suction lifts up to 20 feet from trenches and sumps, some H Series casings come in an optional self-priming chamber design with an integral check valve. Please consult the factory for more information on the HSP Self-Priming Series and available casings.

Flanged Ports

Pump casings are fitted with ANSI Raised Face flanges through 900 Lbs. as standard with a number of alternative flange designs available upon request.

Custom Design

Special combinations of the listed options, or custom designed features and capabilities are available by request. Please consult the factory for all special applications and feature

HBT Series Basic Assembly

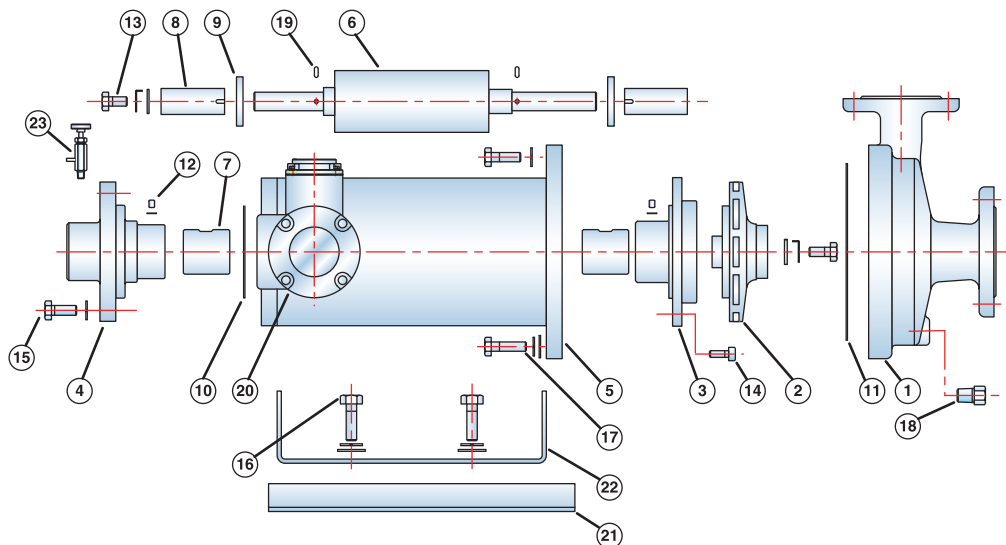

No.	Description	No.	Description	No.	Description	No.	Description
1	Casing	7	Bearing	13	Rotor Bolt	19	Pin
2	Impeller	8	Sleeve	14	F.b.h. Bolt	20	Terminal Box
3	F.b. Housing	9	Collar	15	R.b.h. Bolt	21	Base
4	R.b. Housing	10	Rear Gasket	16	Support Bolt	22	Support Brkt
5	Stator Ass'y	11	Front Gasket	17	Casing Bolt	23	Bleed Valve
6	Rotor Ass'y	12	Set Screw	18	Drain Plug		

Pump Model		Options			Motor			
1	2	3	4	5	6	7	8	9

PUMP MODEL

- ① PUMP SERIES
 HBT: Basic Type
 HHP: High Temperature Heat-Proof
 HRC: Reverse Circulation Series
 HHJ: High Melting Point Heating Jacket Series
 HCM: High Temperature Cooling Jacketed Motor
 HSS: Slurry Separate Series
 HSJ: Slurry Separate with Steam Jacket Series
 HSP: Self-Priming Series
 HAS: Absorption Solution Series
 HAR: Absorption Refrigeration Series
 HSD: Special Design

- ② PUMP CASING NO.
 (See the listing on the next page)
 403
 501
 601

OPTIONS

- ③ PUMP CASING FLANGE TYPE
 A1 : ANSI 150# RF Flange
 A3 : ANSI 300# RF Flange
 A4 : ANSI 400# RF Flange
 A6 : ANSI 600# RF Flange
 A9 : ANSI 900# RF Flange
 ALPHABET: Special Types

- ④ CONSTRUCTION (WETTED PARTS)
 (Primary Material)
 S4: Stainless Steel 304
 S6: Stainless Steel 316
 SL: Stainless Steel 316L
 CS: Carbon Steel
 MO: Monel
 HB: Hastelloy B
 HC: Hastelloy C
- ⑤ MOUNTING STYLE
 H: Horizontal
 V: Vertical In Line

MOTOR

- ⑥ MOTOR OUTPUT (HP): ##
- ⑦ MOTOR INSULATION CLASS
 E: E class
 F: F class
 H: H class
 C: C class
 Z: Z class (HHP Series)
- ⑧ MOTOR POLES
 2: 2 - pole - 3500RPM @ 60Hz
 4: 4 - pole - 1750RPM @ 60Hz
 6: 6 - pole - 1150RPM @ 60Hz
 8: 8 - pole - 875RPM @ 60Hz
- ⑨ ENCLOSURE
 T: TELC - Totally Enclosed Liquid Cooled

EXAMPLE HBT 601 - A3 SL H - 02 H 2 T

Engineering Specification

The contractor shall furnish an MTH H Series (horizontal) (vertical base mount) sealless canned centrifugal type pump model _____ of (STAINLESS STEEL 304) (STAINLESS STEEL 316) (STAINLESS STEEL 316L) (CARBON STEEL) (MONEL) (HASTELLOY - B) (HASTELLOY - C) construction.

The pump shall be of dual containment design to prevent pumpage from leaking to the environment in the event of a

liner breach. The pump shall be mounted to a _____ HP 3 phase _____ Hertz _____ volt _____ RPM, sealless canned motor; equipped with a (remote) (integral) mounted electrically controlled bearing monitor that detects both the motor's rotation direction and radial bearing wear. Each pump shall have a capacity of _____ GPM (1.5 to 2,100 GPM) when operating at a total head of _____ feet (up to 410 ft.) and a suction pressure of _____ feet for _____ (fluid) with a _____ specific gravity

and a _____ viscosity at the nominal process temperature of _____ degrees F. The unit will be tested to the equivalent water performance prior to shipment. The pump (will) (will not) be equipped with an inducer and will have an NPSH requirement of _____ feet or less. The motor shall be sized to prevent overloading at (the highest flow condition listed in this specification) (the end-of-curve condition indicated on the performance curve).

Pump Casing Dimensions

Casing Number	Pump Size (Suction X Discharge X Max. Imp.)			B	C	D	E*
200	3/4"	1/2"	5 3/4"	6.69	2.76	4.72	0
400	1 1/2"	1"	5 3/4"	7.48	2.56	5.51	0
401G	1 1/2"	1"	7"	9.45	3.94	6.50	0
403G	1 1/2"	1"	8 1/2"	11.22	3.94	7.87	0
404T	1 1/2"	1"	10 1/2"	13.78	3.54	9.25	0
501G	2"	1 1/2"	7"	9.45	3.94	7.09	0
502T	2"	1 1/2"	8 1/4"	11.22	3.74	8.27	0
504T	2"	1 1/2"	10 1/2"	13.78	3.74	9.45	0
601G	2 1/2"	2"	7"	9.45	3.74	7.48	0
602T	2 1/2"	2"	8 1/2"	11.22	3.74	8.27	0
604T	2 1/2"	2"	10 1/2"	13.78	3.74	9.45	0
801T	3"	2 1/2"	7 1/4"	9.84	4.92	7.87	0
802T	3"	2 1/2"	8 1/4"	11.22	3.94	8.66	0
802	3"	2 1/2"	10 5/8"	13.78	3.74	9.45	6.06
102	4"	3"	7 1/2"	9.84	3.35	7.09	4.72
111	4"	3"	8 1/2"	11.81	3.54	8.66	4.92
1123	4"	3"	10 1/4"	13.78	4.92	9.84	0
201	5"	4"	7"	11.22	3.94	7.09	4.92
2132	5"	4"	10"	13.78	6.30	11.02	0
051	6"	5"	10"	13.78	5.12	12.20	0
0512	6"	5"	10 5/8"	13.78	7.09	12.80	0
2005	8"	6"	11 1/2"	14.96	6.30	15.75	0

Note: Dimension "E" is the horizontal distance from the center of the suction to the center of the discharge. Zero indicates top centerline discharge.

Motor Dimensions

HORSEPOWER	S	H	T	R	Q	K	Z
2 - 3	13.6	6.5	2.0	8.3	7.5	12.2	8.7
5 - 10	16.7	9.3	3.2	11.0	9.5	17.3	11.0
15	19.7	11.0	3.2	12.6	10.2	19	11.8
20	20.5	11.0	3.2	14.2	10.2	20.5	11.8
30	22.6	12.1	3.9	15.8	11.0	23.6	12.6
40	24.6	12.1	3.9	17.7	11.0	25.6	12.6
50	33.3	12.6	3.9	21.7	13.8	29.5	16.1
60	34.8	12.6	3.9	23.2	13.8	31.1	16.1
75	35.4	13.0	3.9	25.6	15.8	33.5	17.7
100	40.4	17.1	4.9	22.1	17.3	31.5	19.7
120	42.3	17.1	4.9	23.6	17.3	33.5	19.7
150	44.3	17.1	4.9	25.6	17.3	35.4	19.7
175	47.2	19.7	5.9	27.6	19.7	39.4	22.8

Note: motor dimensions are for hbt series basic units only. Other series motor dimensions may vary. Consult factory for specific motor series dimensions. All dimensions in inches.

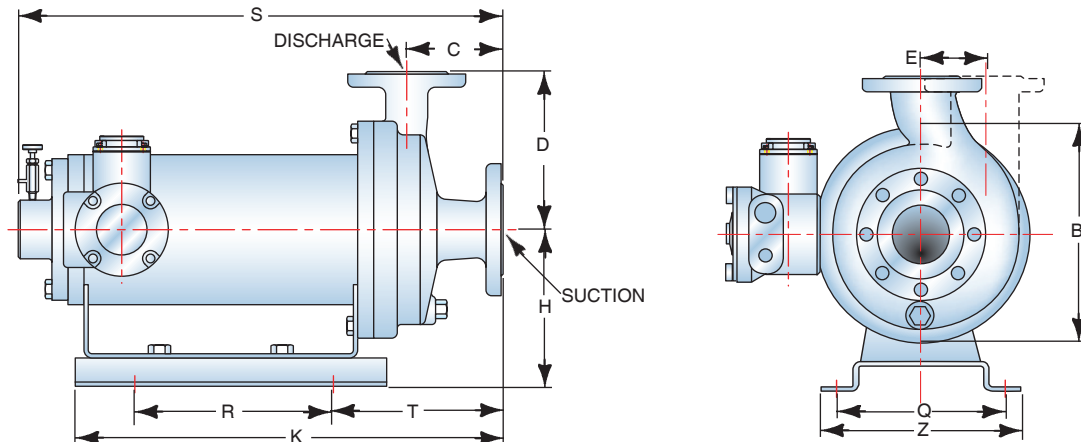

H Series Performance Curves (3450 RPM)

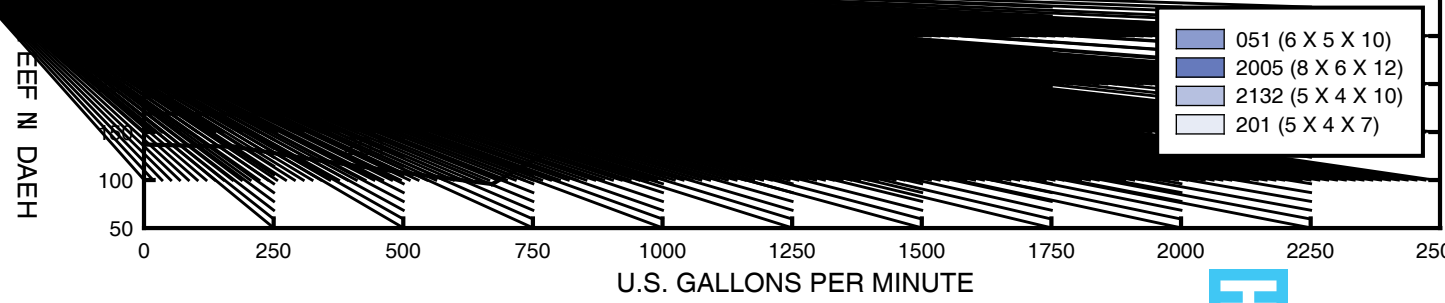
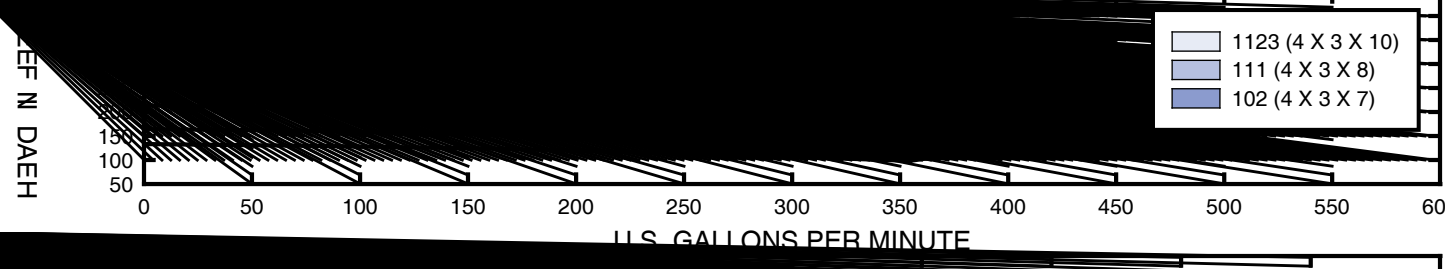
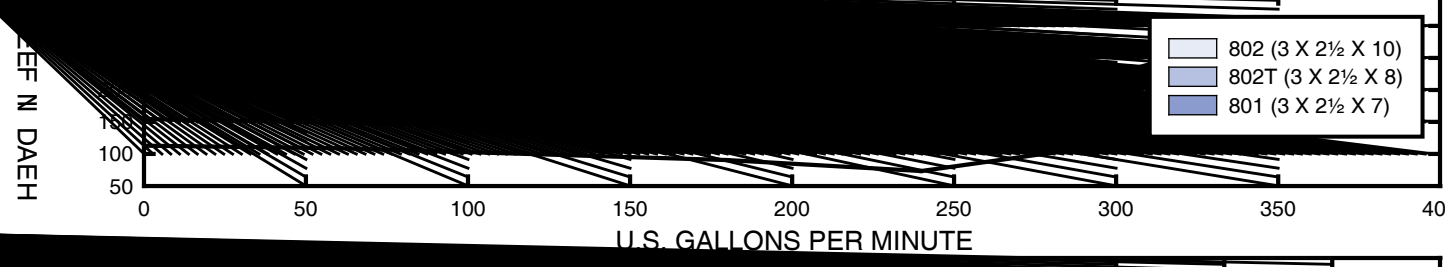
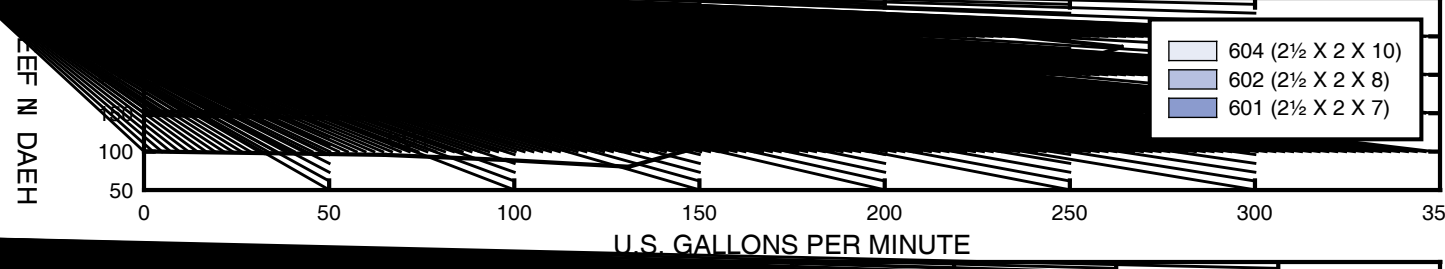
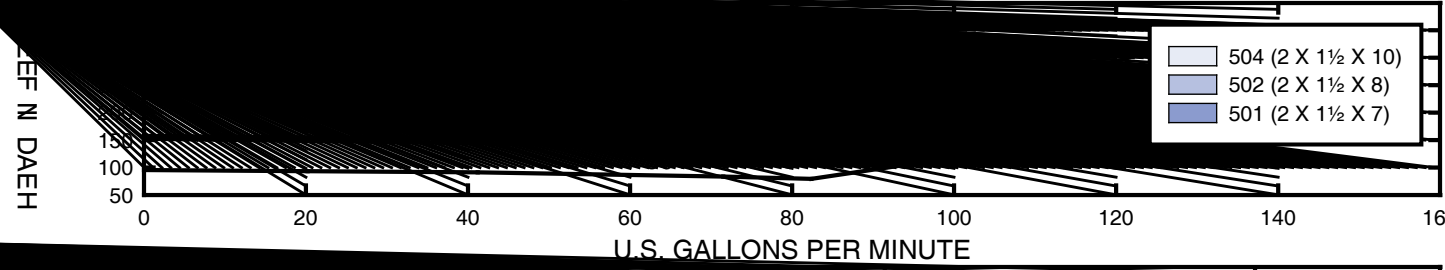
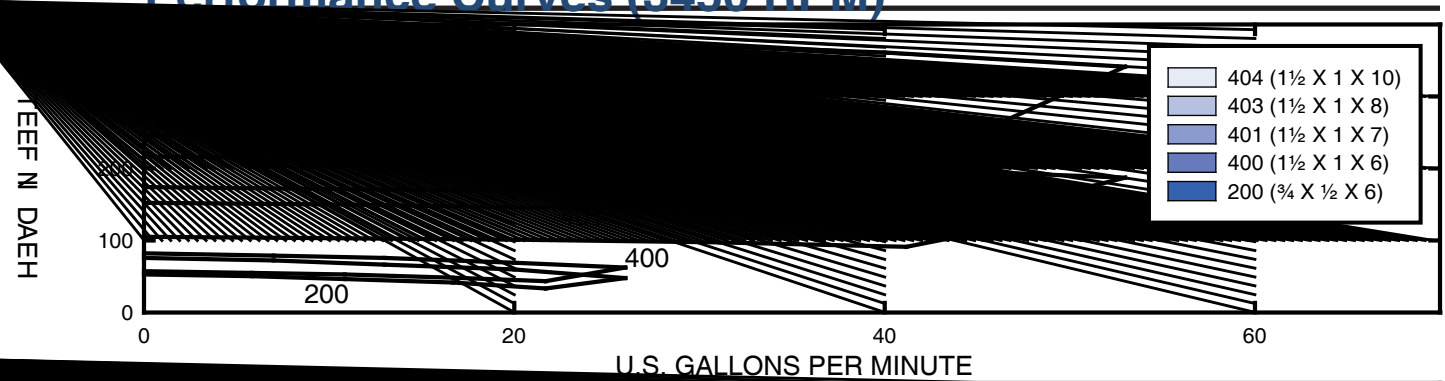

Note: Pump curves are for 60Hz 2-Pole operation and are generally applicable to HBT, HCM, HHJ, HRC, HHP, HSP, HSS, and HSJ Series, but some casings may not be available due to maximum HP restrictions of certain series or other limitations. All of these products are engineered to customer specifications in consideration of the particular application. Refer to the HRC•HAS•HAR brochure for specific performance data for those series.



MTH PUMPS
 401 West Main Street • Plano, IL 60545-1436
 Phone: 630-552-4115 • Fax: 630-552-3688
 Email: SALES@MTHPUMPS.COM
 http://WWW.MTHPUMPS.COM