

# NON-ELECTRIC CONDENSATE PUMPS

## WPT Series

### Pump Trap Combinations

WPT Series Pump/Trap combinations simplify Selection & Installation of Pressure Motive Pumps

- 5 size ranges available
- Up to 13,000 lbs/hr of condensate load

#### TYPICAL APPLICATIONS

The Watson McDaniel **WPT Pump-Trap Combinations** are excellent for draining heat exchangers or other equipment that is being fed by a temperature regulator or a temperature control valve. In these applications, the steam pressure in the heat exchanger may not be sufficient to overcome the back pressure in the condensate return line. When this condition occurs, the pressure powered pump takes over and uses high pressure steam supplied to the pump to discharge the condensate through the trap. When sufficient pressure does exist, the system functions like a standard steam trap.

#### PUMP-TRAP FEATURES

- Steam trap and pump are pre-mounted together on a single base for easy installation
- Engineering and selection is simplified.

WPT1 - 1" x 1" (PMPM with 1 1/2" FTE200)

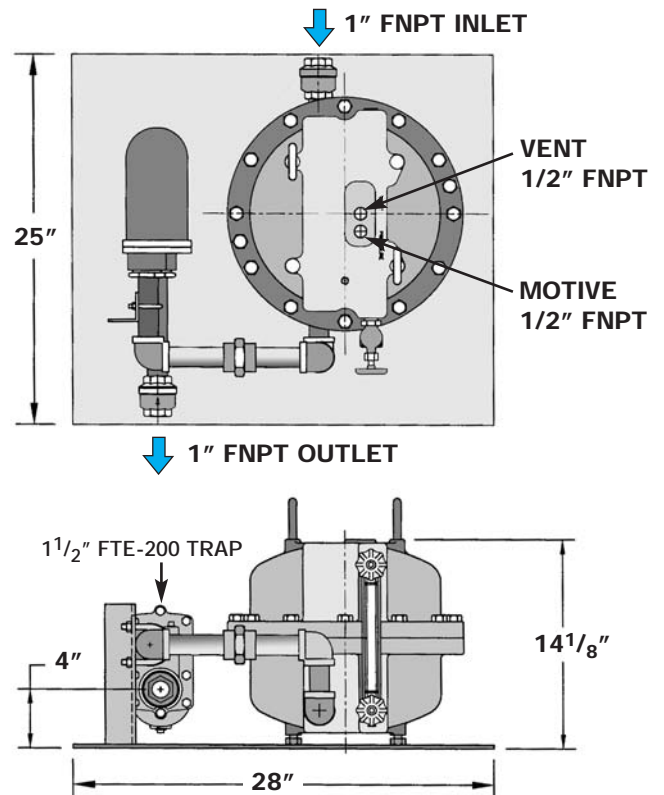

CAPACITIES - Condensate (lbs/hr) Using steam as a motive pressure

Motive Pressure (PSIG)	Total Back Pressure (PSIG)	WPT 1	WPT 2	WPT 3	WPT 4	WPT 5
		1" x 1" 6" Head	1 1/4" x 1 1/4" 6" Head	1 1/2" x 1 1/2" 12" Head	2" x 2" 12" Head	3" x 2" 12" Head
5	2	185	335	1310	2320	4270
10	5	370	648	1760	3740	6230
10	2	502	898	2350	5640	9450
25	15	958	1590	2700	4690	7230
25	10	1240	2090	3020	5970	9370
25	5	1490	2570	3780	6850	11400
50	40	1010	1610	2090	3410	5040
50	25	1220	1970	3620	6650	10200
50	10	1600	2680	4080	7140	11500
75	60	993	1560	2250	3730	5660
75	40	1380	2190	3470	6010	8770
75	15	1550	2580	4390	7920	12400
100	80	612	951	2620	4390	6140
100	60	1210	1900	3390	5780	8120
100	40	1540	2440	4310	6940	10000
100	15	1720	2840	4620	8000	12300
125	115	195	301	2280	3490	4440
125	100	488	753	2880	4420	5720
125	80	836	1300	3520	5700	7630
125	60	1280	2000	4110	6880	9390
125	40	1420	2270	4910	7800	11100
125	15	1470	2440	5120	8420	12900
150	120	588	904	2560	3640	5100
150	100	977	1510	3020	4610	6270
150	80	1060	1640	3630	5780	8140
150	60	1340	2100	4230	6910	9920
150	40	1420	2260	4830	7930	11700
150	15	1450	2390	5230	8590	13300

# NON-ELECTRIC CONDENSATE PUMPS

WPT2 - 1 1/4" x 1 1/4" (PMPM with 2" FTE200)

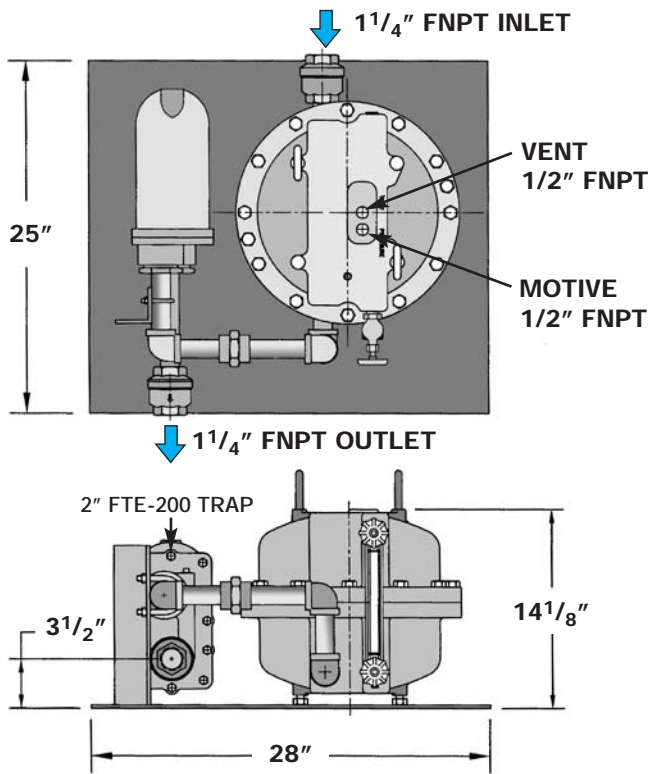

WPT3 - 1 1/2" x 1 1/2" (PMPLS with 2" FTE200)

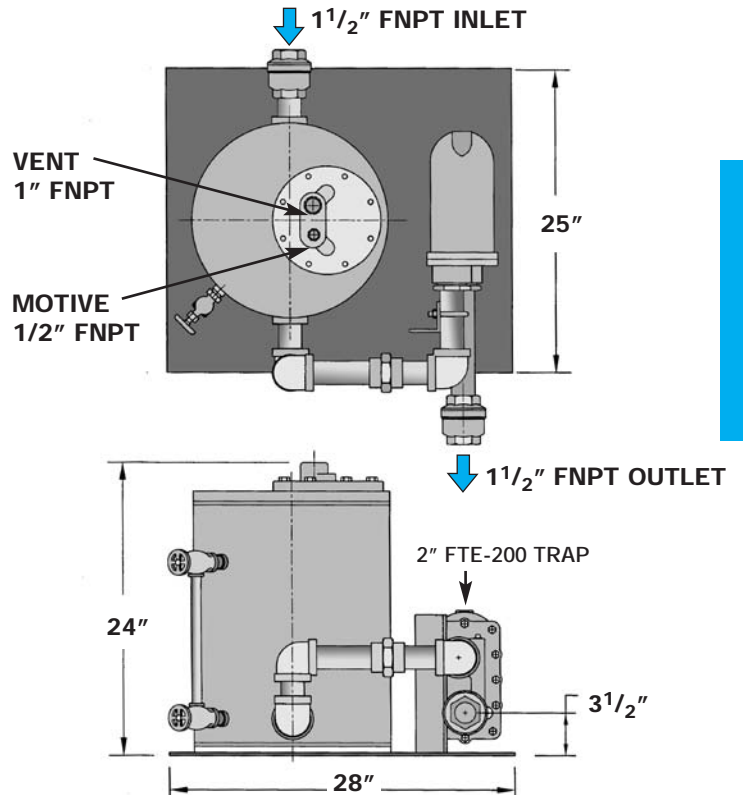

WPT4 - 2" x 2" (PMPC with 2" FTE200)

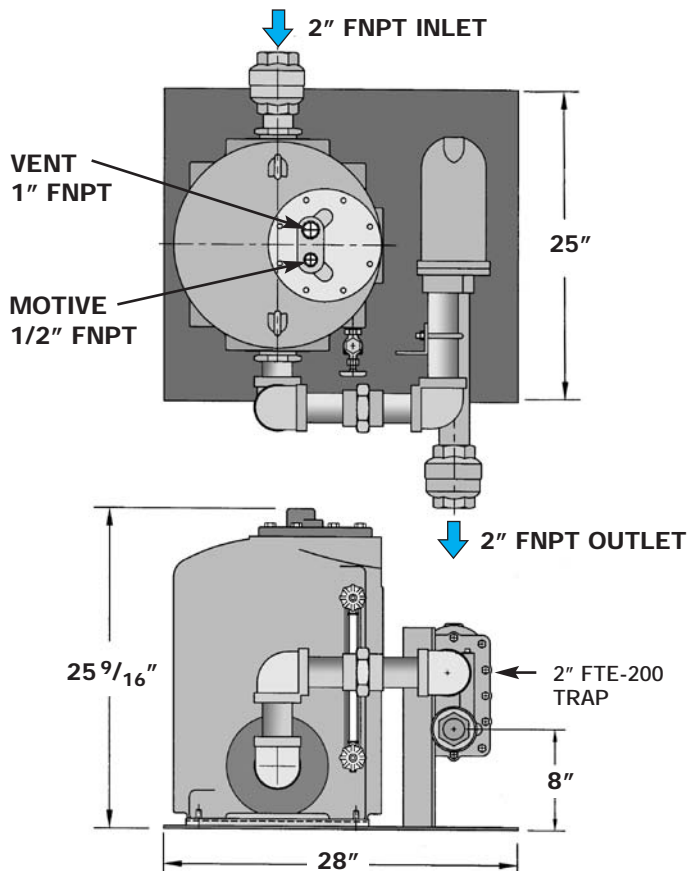

WPT5 - 3" x 2" (PMPC with 2 1/2" FTE200)

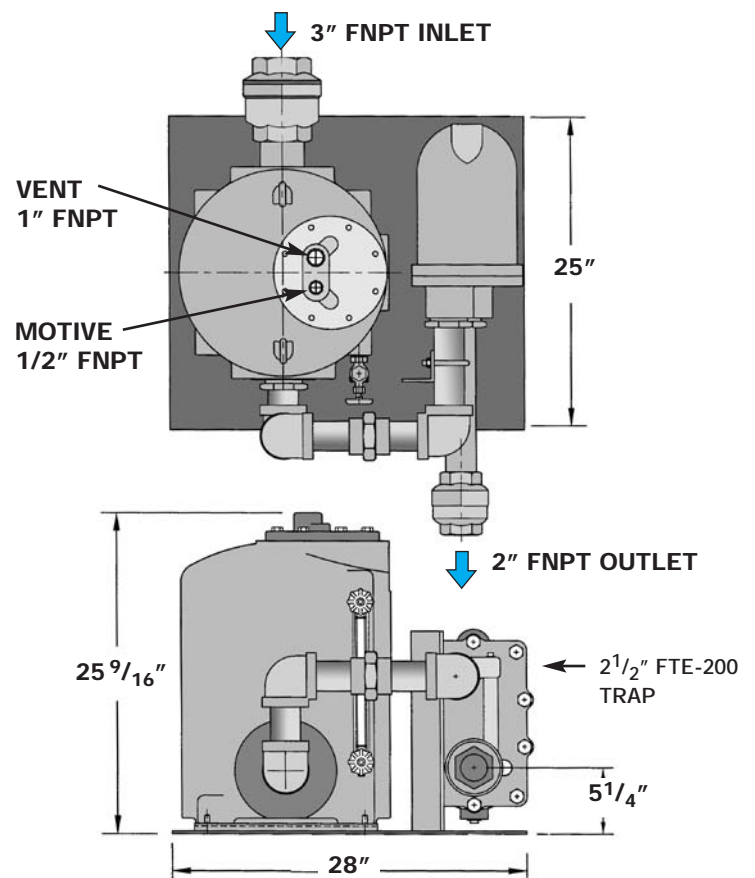

PUMPS