

LIQUID DRAINERS

WLD600/601 Series

Float Type Liquid Drain Trap

Watson McDaniel reserves the right to change the designs and/or materials of its products without notice.
©2006 Watson McDaniel Company

Model	WLD600 / WLD601†
Sizes	3/4", 1", 1 1/2", 2", 3", 4"
Connections	NPT, SW, Flanged
Body Material WLD600	Carbon Steel †
Body Material WLD601	316 SS
PMO Max. Operating Pressure	450 PSIG
TMO Max. Operating Temperature	750°F
PMA Max. Allowable Pressure	*990 PSIG @ 100°F
TMA Max. Allowable Temperature	*750°F @ 670 PSIG

† WLD601 Body & Cover Material is 316 SS

* 3/4" - 2" only.

Note: For dimensions and capacities of 3" & 4" liquid drains traps refer to model FT600 in the Steam Trap section.



TYPICAL APPLICATION

The WLD600/601 Series is used in applications where immediate and continuous discharge of large amounts of liquid is required. Typically used in heavy industrial process applications for draining condensate from air or other gases.

HOW IT WORKS

This liquid drainer has a float-operated valve that gives the trap a modulating flow characteristic. The amount of liquid flowing into the drainer is sensed by the float which positions the main valve to discharge the liquid at the same rate as it is received.

FEATURES

- All stainless steel internals for long life service
- Body & cover available in Carbon Steel or 316 SS
- Rugged construction designed for heavy industrial applications
- In-line repairable

SAMPLE SPECIFICATION

The liquid drain trap shall be float operated with a cast steel body and all stainless steel internals. The unit shall be in-line repairable and equipped with a FNPT threaded connection for the use of a balance line.

INSTALLATION

The installation should include isolation valves to facilitate maintenance and an in-line strainer. The trap must be level and upright for the float mechanism to operate. The 2" traps should not be supported by the piping alone. Trap must be sized and properly located in the system. Piping hook-up must include an equalizing line.

MAINTENANCE

Close isolation valves prior to any maintenance. All working components can be replaced with the drain trap remaining in the line. Repair kits include float, valve seat & disc and gaskets. For full maintenance details see Installation and Maintenance Manual.

OPTIONS

Body and cover for Model WLD601 is 316 SS.

MATERIALS

Body & Cover WLD600	Cast Steel, ASTM A-216 WCB
Body & Cover WLD601	Cast 316 SS
Cover Studs	Steel, SA 193, Gr B7
Cover Nuts	Steel, SA 194, Gr 2H
Cover Gasket	Stainless Steel Reinforced Grafoil
Valve Assembly	Stainless Steel, AISI 431
Gasket, Valve Assembly	Stainless Steel Reinforced Grafoil
Pivot Assembly	Stainless Steel, 17-4 PH
Mounting Screws	Stainless Steel Hex Head, 18-8
Float	Stainless Steel, ASTM 240 TY 304

HOW TO ORDER

Refer to the capacity chart to determine which model is required.

Example Model Code: WD600-065-14
specifies 65 PMO, 1" NPT
Carbon Steel Body & Cover

LIQUID DRAINERS

WLD600/601 Series

Float Type Liquid Drain Trap

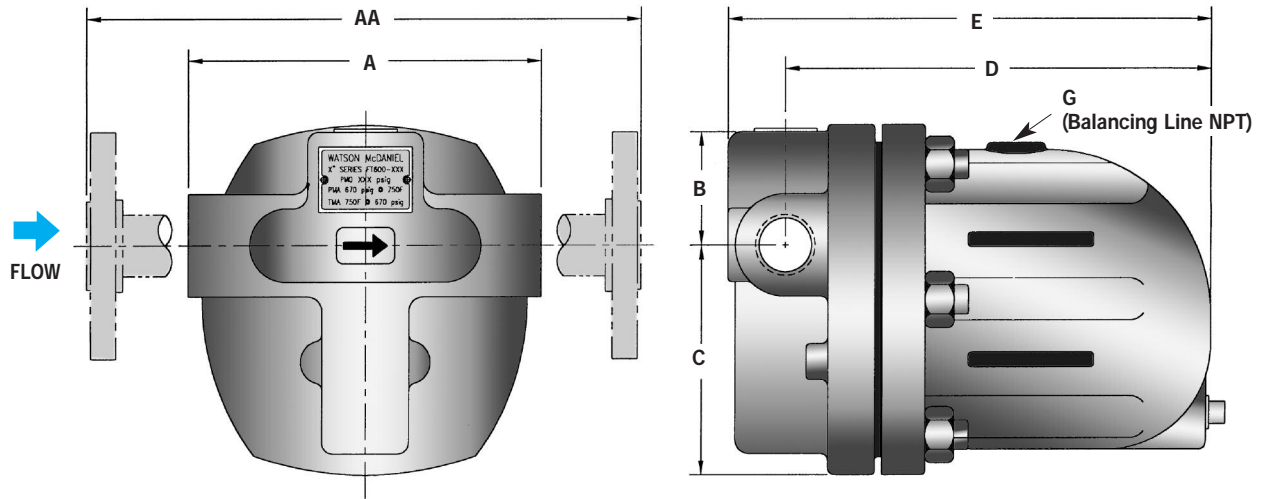

DIMENSIONS – inches/pounds

Size	A	AA	B	C	D	E	F	G*	Weight (lbs)	
									NPT/SW	FLG
3/4"	6 ¹ / ₈	10 ¹ / ₈	2 ¹ / ₈	3 ⁷ / ₁₆	7 ⁷ / ₁₆	8 ⁷ / ₁₆	5 ¹³ / ₁₆	3/8	25	31
1"	6 ¹ / ₂	10 ⁷ / ₁₆	2 ¹ / ₂	5 ¹ / ₂	8 ⁷ / ₁₆	9 ¹ / ₂	6 ⁵ / ₁₆	3/8	31	36
1 ¹ / ₂ "	9 ¹³ / ₁₆	14	3 ⁷ / ₁₆	9	10 ⁷ / ₁₆	11 ¹⁵ / ₁₆	7 ¹³ / ₁₆	1/2	82	91
2"	11 ¹³ / ₁₆	16	3 ¹ / ₈	7 ⁷ / ₁₆	11 ¹ / ₈	13 ⁵ / ₁₆	6 ¹³ / ₁₆	1/2	93	107

* Balancing Port available within 1/2" flanged connection. Specify on order.

COLD WATER CAPACITIES – (lbs/hr)

PMO (PSI)	Size (in.)	Orifice (in.)	Differential Pressure (PSI)																	
			2	5	10	20	30	40	50	65	70	80	100	145	200	250	300	350	450	
65	3/4"	.156	340	520	730	1010	1220	1440	1560	1770										
65	1"	.276	1390	2140	2970	4130	5000	5730	6370	7210										
65	1 ¹ / ₂ "	.689*	4160	6430	8920	12380	15000	17190	19110	21630										
65	2"	1.122*	14730	22720	31540	43790	53060	60790	67570	76500										
145	3/4"	.126	210	320	450	620	760	870	960	1090	1130	1200	1340	1590						
145	1"	.205*	690	1070	1490	2060	2500	2870	3190	3610	3740	3980	4420	5270						
145	1 ¹ / ₂ "	.591*	2360	3630	5050	7010	8490	9730	10810	12240	12670	13500	15000	17890						
145	2"	.807*	5840	9010	12510	17370	21040	24110	26800	30340	31420	33470	37200	44360						
200	3/4"	.106	170	260	360	500	600	690	770	870	900	960	1060	1270	1480					
200	1"	.185	450	690	960	1330	1620	1850	2060	2330	2410	2570	2860	3410	3970					
200	1 ¹ / ₂ "	.531*	1650	2550	3540	4910	5950	6820	7580	8580	8890	9470	10520	12540	14610					
200	2"	.657*	2890	4460	6190	8590	10410	11930	13250	15010	15540	16560	18400	21940	25540					
300	3/4"	.079	80	130	180	250	300	340	380	430	450	480	530	630	730	820	890			
300	1"	.156	340	520	730	1010	1220	1400	1560	1770	1830	1950	2160	2580	3010	3340	3640			
300	1 ¹ / ₂ "	.531*	1650	2550	3540	4910	5950	6820	7580	8580	8890	9470	10520	12540	14610	16230	17700			
300	2"	.657*	2890	4460	6190	8590	10410	11930	13250	15010	15540	16560	18400	21940	25540	28930	30950			
450	3/4"	.063	50	70	100	140	160	190	210	240	250	260	290	350	400	450	490	530	590	
450	1"	.126	210	320	450	620	760	870	960	1090	1130	1200	1340	1590	1860	2060	2250	2420	2720	
450	1 ¹ / ₂ "	.531*	1650	2550	3540	4910	5950	6820	7580	8580	8890	9470	10520	12540	14610	16230	17700	19040	21440	
450	2"	.657*	2890	4460	6190	8590	10410	11930	13250	15010	15540	16560	18400	21940	25540	28390	30950	33290	37490	