



Edco SHA-1210 120 VAC — 1 Phase

The Edco SHA-1210 filtering surge protector absorbs power line noise and switching transients that other suppressors and RFI filters pass through. The Edco SHA-1210 can replace the RFI filter when high attenuation of noise above 25 MHz is not required.

If random time-base, memory loss, or other problems are affecting some of your intersections, this state-of-the-art protector can be of great benefit when properly installed.

Features

- Multi-stage hybrid design
- 60 dB maximum noise filtering
- Nanosecond response time
- Incorporates series choke
- 5 year warranty

General Technical Specifications

Part Number	Edco SHA-1210
Operating Voltage	120 VAC
Clamping Voltage	395 VAC
Operating Current	10A
Peak Surge Current	32.5 kA/Mode, 52 kA/Phase, 84.5 kA/Total
Operating Frequency	47-63 Hz
EMI Attenuation	60 dB typ
SPD Technology	MOVs w/L-C Filter
Modes of Protection	L-N, L-G, N-G
Status Indication	NA
Connection Type	1/4-20 Stainless Steel Stud
Operating Temperature	-40°C to +85°C
Dimensions (Inches)	2.375H x 3.125W x 7.125L
Weight	2 lbs

Mounting

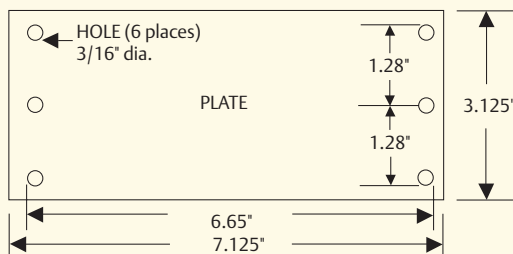

Installation

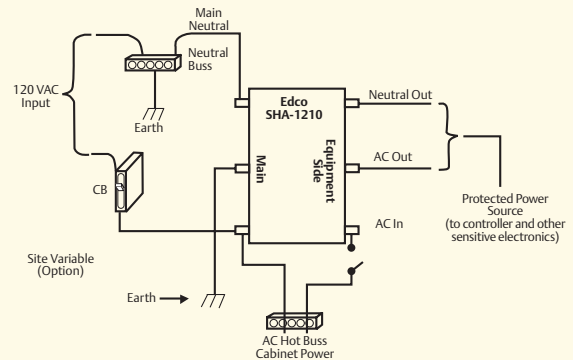

Caution:

1. This product could become excessively hot and rupture in the rare event of power line conditions or surge that exceed its rated operating specification. Appropriate precautions should be exercised.
2. High voltages are present on electrical termination. Unit should be serviced by qualified personnel only.