

LSU/LSSU/LSSUI Light Slopeable/Skewable U Hangers for I-Joists and SCL



This product is preferable to similar connectors because of
a) easier installation, b) higher loads, c) lower installed cost,
or a combination of these features.

This series attaches joists or rafters to headers, sloped up or down,
and skewed left or right, up to 45°.

MATERIAL: See table
FINISH: Galvanized

INSTALLATION: • Use all specified fasteners.
See General Notes.

- Attach the sloped joist at both ends so that the horizontal force developed by the slope is fully supported by the supporting members.
- Web stiffeners required for I-joist applications.
- To see an installation video on this product, visit www.strongtie.com.

CODES: See page 12 for Code Reference Key Chart.

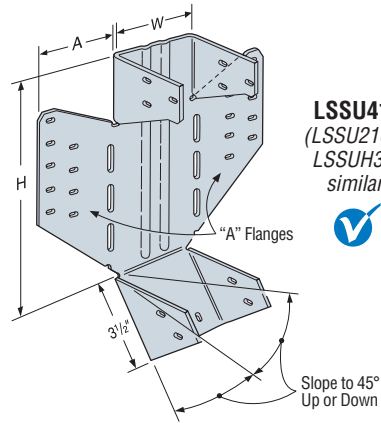

LSSU410
(LSSU210-2,
LSSUH310
similar)



LSU and LSSU INSTALLATION SEQUENCE

(For Skewed or Sloped/Skewed Applications)

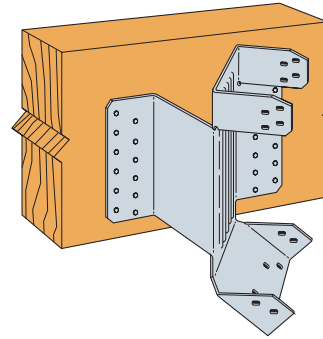
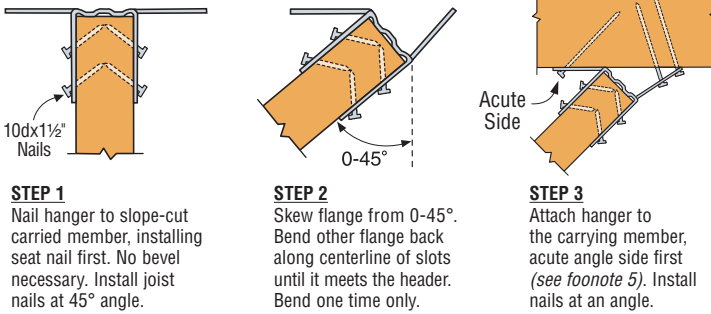

The LSU5.12 must be factory-skewed 0° to 45°. It may be field-sloped to 45°. (LSU4.12, LSU4.28 and LSU3510-2 similar)

Hanger shown skewed right

These products are available with additional corrosion protection. Additional products on this page may also be available with this option, check with Simpson Strong-Tie for details.

Actual Joist Width	Model No.	Ga	Dimensions			Fasteners		Allowable Loads								Code Ref.
			W	H	A	Face	Joist	DF/SP Species Header				SPF/HF Species Header				
								Uplift (160)	Floor (100)	Snow (115)	Const. (125)	Uplift (160)	Floor (100)	Snow (115)	Const. (125)	
SLOPED ONLY HANGERS																
1½	LSSU210	18	1¾	8½	1⅝	10-10d	7-10dx1½	875	1110	1275	1390	625	960	1105	1200	18, L2, F7
1¾	LSSU125	18	1⅞	8½	1½	10-10d	7-10dx1½	875	1110	1275	1390	625	960	1105	1200	
2	LSSU2.06	18	2¼	8½	1¾	10-10d	7-10dx1½	875	1110	1275	1390	625	960	1105	1200	
2¼	LSSU2.1	18	2½	8½	1¾	10-10d	7-10dx1½	875	1110	1275	1390	625	960	1105	1200	170
2¼ - 2⅝	LSSU135	18	2⅝	8½	1⅝	10-10d	7-10dx1½	875	1110	1275	1390	625	960	1105	1200	
2½ - 2⅞	LSSUH310	16	2⅞	8½	3⅜	18-16d	12-10dx1½	1150	2295	2295	2295	990	1930	1930	1930	170
3	LSSU210-2	16	3⅜	8½	2⅞	18-16d	12-10dx1½	1150	2430	2795	3035	990	2160	2485	2700	18, L3, F7
3½	LSSU410	16	3⅞	8½	2⅝	18-16d	12-10dx1½	1150	2430	2795	3035	990	2160	2485	2700	
4	LSU4.12	14	4⅞	9	2¼	24-16d	16-10dx1½	1150	3215	3700	4020	990	2785	3200	3480	
4⅞	LSU4.28	14	4¼	9	2⅝	24-16d	16-10dx1½	1150	3215	3700	4020	990	2785	3200	3480	170
4½ - 4¾	LSU3510-2	14	4¾	8⅞	3⅝	24-16d	16-10dx1½	1150	3215	3700	4020	990	2785	3200	3480	
5	LSU5.12	14	5⅞	9	2¼	24-16d	16-10dx1½	885	3215	3700	3785	760	2785	3200	3280	
SKewed HANGERS OR SLOPED AND SKewed HANGERS																
1½	LSSU210	18	1¾	8½	1⅝	9-10d	7-10dx1½	785	995	1145	1205	625	860	995	1050	18, L2, F7
1¾	LSSU125	18	1⅞	8½	1½	9-10d	7-10dx1½	785	995	1145	1205	625	860	995	1050	
2	LSSU2.06	18	2¼	8½	1¾	9-10d	7-10dx1½	785	995	1145	1205	625	860	995	1050	
2¼	LSSU2.1	18	2½	8½	1¾	9-10d	7-10dx1½	785	995	1145	1205	625	860	995	1050	170
2¼ - 2⅝	LSSU135	18	2⅝	8½	1⅝	9-10d	7-10dx1½	785	995	1145	1205	625	860	995	1050	
2½ - 2⅞	LSSUH310	16	2⅞	8½	3⅜	14-16d	12-10dx1½	1150	1600	1600	1600	990	1385	1385	1385	170
3	LSSU210-2	16	3⅜	8½	2⅞	14-16d	12-10dx1½	1150	1625	1625	1625	990	1365	1365	1365	18, L3, F7
3½	LSSU410	16	3⅞	8½	2⅝	14-16d	12-10dx1½	1150	1625	1625	1625	990	1365	1365	1365	
4	LSU4.12 ³	14	4⅞	9	2¼	24-16d	16-10dx1½	1150	2300	2300	2300	990	1990	1990	1990	
4⅞	LSU4.28 ³	14	4¼	9	2⅝	24-16d	16-10dx1½	1150	2300	2300	2300	990	1990	1990	1990	170
4½ - 4¾	LSU3510-2 ³	14	4¾	8⅞	3⅝	24-16d	16-10dx1½	1150	2300	2300	2300	990	1990	1990	1990	
5	LSU5.12 ³	14	5⅞	9	2¼	24-16d	16-10dx1½	885	1790	1790	1790	760	1550	1550	1550	

1. Roof loads are 125% of floor loads unless limited by other criteria.
2. Uplift loads include a 60% increase for wind or earthquake loading with no further increase is allowed; reduce where other loads govern.
3. LSU3510-2, LSU4.12, LSU4.28 and LSU5.12 skew option must be factory-ordered.
4. Minimum 11" joist height for LSU3510-2, LSU4.12, LSU5.12; 9½" for all others.
5. For skewed LSSU/LSSUI hangers, the inner most face fasteners on the acute angle side are not installed.
6. 10dx1½" nails may not be used for face nails on skewed or sloped and skewed LSU/LSSU/LSSUI hangers.
7. **NAILS:** 16d = 0.162" dia. x 3½" long, 10d = 0.148" dia. x 3" long, 10dx1½ = 0.148" dia. x 1½" long. See page 16-17 for other nail sizes and information.