

MAS/MASA/MASAP/MASB/MASP Mudsill Anchors



This product is preferable to similar connectors because of a) easier installation, b) higher loads, c) lower installed cost, or a combination of these features.

MAS style mudsill anchors are easy to install for both the concrete and framing contractor. They are suitable for either stemwall or slab foundations and easily mount on the forms before the pour, simplifying finishing and reducing anchor mislocation problems. The MAS eliminates the need to drill the mudsill and can be installed three different ways to provide flexibility when stud placement or sheathing becomes an issue (see table below).

The new and improved MASA/P provides the installation advantages of mudsill anchors combined with the maximum allowable on-center spacing. The new stronger design provides parallel-to-wall load carrying capacity that meets or exceeds most cast-in-place anchors. This allows for a one-to-one replacement of 1/2" bolts on 2x or 3x sills and 5/8" bolts on a 2x sill.

The different models of mudsill anchors are designed for specific applications:

- MAS/MASA—installed at the top of the form
- MASP/MASAP—for panelized forms
- MASB—used in concrete masonry units.

MATERIAL: 16 gauge

FINISH: Galvanized, all available in ZMAX® coating.

See Corrosion Information, page 10-11.

INSTALLATION: • Use all specified fasteners. See General Notes.

• **MAS/MASP/MASA/MASAP**

- Concrete shall have a minimum $f'_c = 2500$ psi.
- Spalling—Full published capacity is achieved so long as a maximum height of 1 1/4" and a maximum depth of 7/8" is not exceeded. Any exposed portion of the mudsill anchor must be protected against possible corrosion.
- For prescriptive anchor spacing refer to page 23.
- Testing shows that these mudsill anchors can be used in lieu of code required anchor bolts and square washer in high seismic zones. Refer to technical bulletin T-MASSW for additional information (see page 191 for details).

- **MASB**—Fill CMU cell with concrete grout first, then place MASB into the grouted cell and adjust into position. Attach mudsill to anchor only after the concrete grout cures.
 - CMU shall have a minimum $f'_m = 1500$ psi.
 - The MASB Mudsill Anchors were tested in standard 8" CMU.

CODES: See page 12 for Code Reference Key Chart.

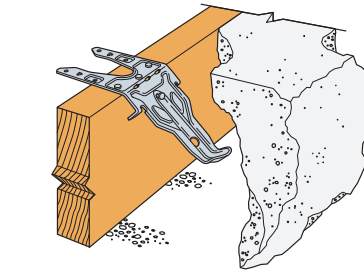
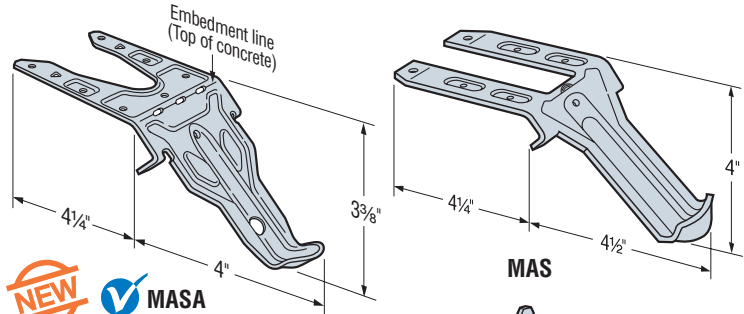

Typical MASA Installation in Concrete (MAS similar)

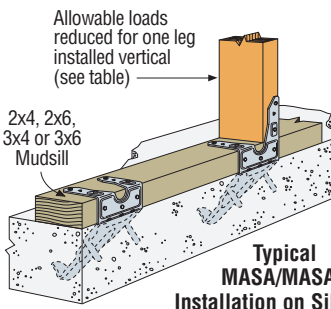

Typical MASA/MASAP Installation on Sill Plate (MAS/MASP similar)

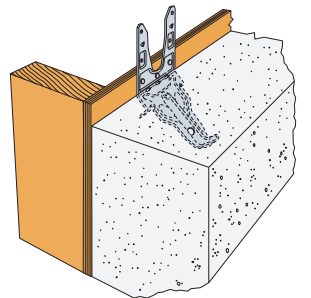
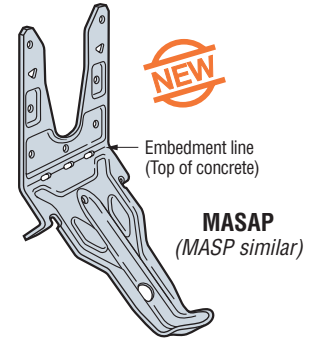

Typical MASAP Installation in Concrete (MASP similar)

These products are available with additional corrosion protection. Additional products on this page may also be available with this option, check with Simpson Strong-Tie for details.

Model No.	Sill Size	Fasteners ⁶		Attached to DF/SP Sill Plate			Attached to HF Sill Plate			Code Ref.
		Sides	Top	Allowable Loads ¹ (160)			Allowable Loads ¹ (160)			
				Uplift ²	Parallel to Plate (F ₁)	Perp. to Plate (F ₂)	Uplift ²	Parallel to Plate (F ₁)	Perp. to Plate (F ₂)	
TYPICAL INSTALLATION										
MAS or MASP	2x4, 6	2-10dx1 1/2	4-10dx1 1/2	1005	815	575	680	835	255	IL12 ⁶ , F24
	3x4, 6	4-10dx1 1/2	2-10dx1 1/2	955	835	465	—	—	—	
MASA or MASAP	2x4, 6	3-10dx1 1/2	6-10dx1 1/2	930	1605	800	930	1440	685	170 ⁶
	3x4, 6	5-10dx1 1/2	4-10dx1 1/2	930	1570	685	795	1190	495	
MASB	2x4,6x8	2-10dx1 1/2	6-10dx1 1/2	130	930	410	—	—	—	IL5 ⁶
ONE LEG UP INSTALLATION										
MAS or MASP	2x4, 6	4-10dx1 1/2	2-10dx1 1/2	435	700	240	—	—	—	IL12 ⁶ , F24
MASA or MASAP	2x4, 6	6-10dx1 1/2	3-10dx1 1/2	780	1445	380	715	980	380	170 ⁶
MASB	2x4,6x8	5-10dx1 1/2	3-10dx1 1/2	—	960	360	—	—	—	IL5 ⁶
BOTH LEGS OVER MAX. 1/2" PLYWOOD OR OSB INSTALLATION (See page 23)										
MAS or MASP	2x4, 6	6-10dx1 1/2	—	755	785	260	—	—	—	170 ⁶
MASA or MASAP	2x4, 6	9-10dx1 1/2	—	710	930	280	710	930	225	
MASB	2x4,6x8	8-10dx1 1/2	—	45	295	25	—	—	—	

1. Loads have been increased for short-term loading.
2. For uplift loads, provide attachment from mudsill to building's structural components to prevent cross-grain bending.
3. For stemwall applications, allowable loads are based on a minimum stemwall width of 6".
4. For simultaneous loads in more than one direction, the connector must be evaluated using the Unity Equation. See page 14 under General Instructions for the Designer.
5. Stud-to-plate connectors must be installed on the same side of the plate as the MAS/MASP or MASA/MASAP straps to complete the continuous load path.
6. Testing to new ICC-ES acceptance criteria to be completed in 2009. Reference www.strongtie.com for latest loads and information.
7. **NAILS:** 10dx1 1/2 = 0.148" dia. x 1 1/2" long. See page 16-17 for other nail sizes and information.

MAS/MASA/MASAP/MASB/MASP *Mudsill Anchors*

Prescriptive Anchor Spacing

Model No.	O.C. Spacing to replace 1/2" Anchor Bolt 6' O.C. (160)	O.C. Spacing to replace 5/8" Anchor Bolt 6' O.C. (160)	Min. Concrete End Distance	Min. C-C Spacing
MAS or MASP	5'-0"	4'-0"	4"	8"
MASA or MASAP ⁶	6'-0"	6'-0"	4"	8"
MASB	5'-6"	4'-8"	3 3/4"	7 1/2"

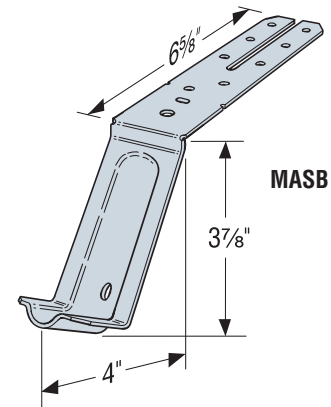

- Place anchors not more than 12" from the end of each sill per code.
- Spacing is based on parallel to plate load direction only.
- CMU shall have a minimum $f_m = 1500$ psi and concrete shall have a minimum $f_c = 2500$ psi.
- Spacing applies to DF, SP, and HF 2x sill plates.
- For installations to rim joist or blocking, MASB spacing is 1'-10" for replacing 1/2" bolts and 1'-6" for 5/8" bolts. MAS/P and MASA/P remain the same as the table.
- When replacing 1/2" sill bolts use 7-10dx1 1/2" nails (minimum nailing) and when replacing 5/8" sill bolts use 9-10dx1 1/2" nails (maximum nailing).

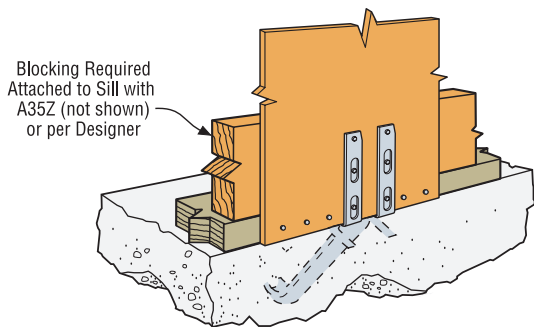

MAS/MASP Rim Joist or Blocking Installation in Concrete over Max. 1/2" Sheathing
(MASA/MASAP/MASB similar)

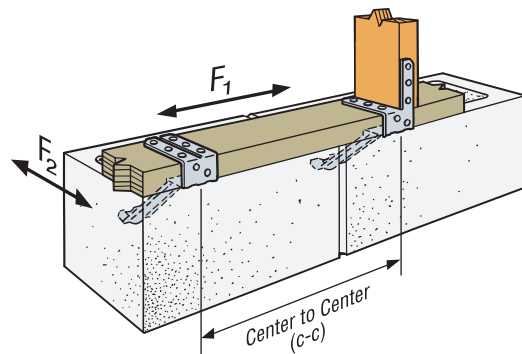

Typical MASB Installation

ALTERNATIVE MUDSILL ANCHOR INSTALLATIONS

ALTERNATE INSTALLATION FOR INSIDE OF WALL CONTINUITY

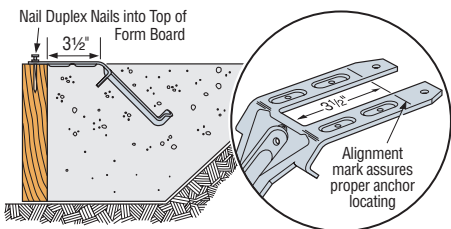

1 STEP 1:
Attach MAS/MASA 3 1/2" from inside of form. After concrete cures, remove nails and bend straps up 90°

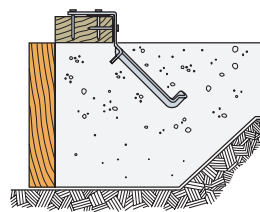

2 STEP 2:
Place mudsill on concrete and nail MAS/MASA over mudsill

ALTERNATE INSTALLATION FOR BRICK LEDGES

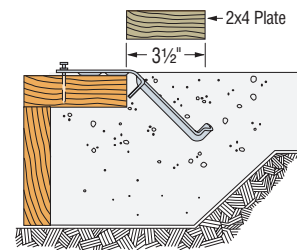

Alternate MAS Installation for Brick Ledges
(MASA similar)