

**TBE** Truss Bearing Enhancers

The TBE transfers load from the truss or girder to plates for bearing-limited conditions, and provides exceptional uplift capacity. Replaces nail-on scabs that provide lower load transfer, or in some cases, an additional ply when needed for bearing. One size works with any number of girder plies.

The table lists allowable loads for TBE4 used on 2x4 and TBE6 used on 2x6 top plates. The table gives the different loads calculated for TBE with and without wood bearing. See Fastener Schedule below and page 135 for Alternate Installation.

**MATERIAL:** 18 gauge **FINISH:** Galvanized. See Corrosion Information, page 10-11.

**INSTALLATION:** • Use all specified fasteners. See General Notes.

- TBE must be installed in pairs.
- Top plate size is 2x4 for TBE4, 2x6 for TBE6. Use alternate installation for TBE4 and TBE6 on larger plates or pre-sheathed walls. See page 135.

**CODES:** See page 12 for Code Reference Key Chart.

These products are available with additional corrosion protection. Additional products on this page may also be available with this option, check with Simpson Strong-Tie for details.

**TBE FASTENER SCHEDULE**

Model No.	Truss Plys	Fasteners per each TBE	
		Rafter	Plate
TBE4	1	10-10dx1½	10-10dx1½
	2 or more	10-10d	10-10d
TBE6	1	10-10dx1½	10-10dx1½
	2 or more	10-10d	10-10d

**NAILS:**  
10d = 0.148" dia. x 3" long,  
10dx1½ = 0.148" dia. x 1½" long.  
See page 16-17 for other nail sizes and information.

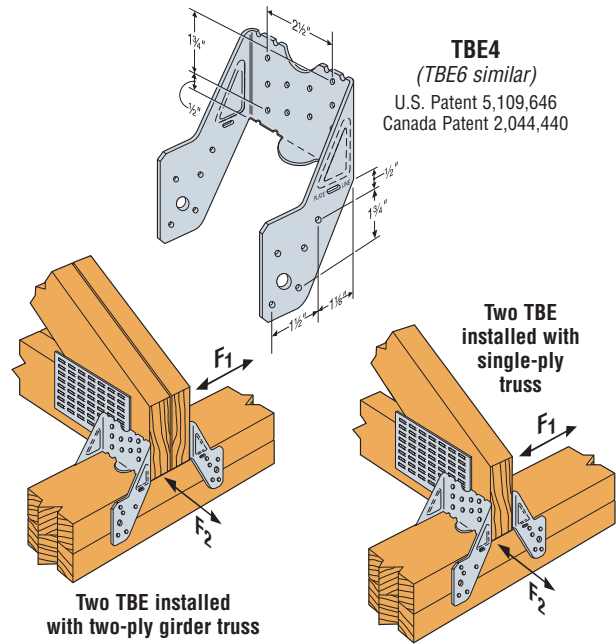

Model No.	Wall Top Plate	Top Plate or Truss Wood Species <sup>2</sup>	No. of Truss Plies	Allowable Loads <sup>1,2,3</sup> (lbs.)								Equivalent Bearing Length <sup>7</sup> of TBE and Top Plate (in.)				Code Ref.			
				Uplift	Download				Lateral (160)		(100)	(115)	(125)	(160)					
					(160)	(100)	(115)	(125)	(160)	(100)					(115)		(125)	(160)	
TBE4	2x4	Douglas Fir Larch	1	850	1820	2095	2230	2230	5100	5375	5510	5510	400	1000	5.44	5.73	5.88	5.88	I13, F12
			2	850	2220	2230	2230	2230	8785	8795	8795	8795	400	1000	4.68	4.69	4.69	4.69	
			3	850	2220	2230	2230	2230	12065	12075	12075	12075	400	1000	4.29	4.29	4.29	4.29	
			4	850	2220	2230	2230	2230	15345	15355	15355	15355	400	1000	4.09	4.09	4.09	4.09	
		Southern Pine	1	850	1820	2095	2230	2230	4785	5060	5195	5195	400	1000	5.65	5.97	6.13	6.13	
			2	850	2220	2230	2230	2230	8155	8165	8165	8165	400	1000	4.81	4.82	4.82	4.82	
			3	850	2220	2230	2230	2230	11120	11130	11130	11130	400	1000	4.37	4.38	4.38	4.38	
			4	850	2220	2230	2230	2230	14085	14095	14095	14095	400	1000	4.15	4.16	4.16	4.16	
		Spruce-Pine-Fir	1	850	1560	1795	1950	2080	3790	4025	4180	4310	375	1000	5.95	6.32	6.56	6.76	
			2	850	1920	2100	2100	2100	6385	6565	6565	6565	375	1000	5.01	5.15	5.15	5.15	
			3	850	1920	2100	2100	2100	8615	8795	8795	8795	375	1000	4.50	4.60	4.60	4.60	
			4	850	1920	2100	2100	2100	10845	11025	11025	11025	375	1000	4.25	4.32	4.32	4.32	
		Hem Fir	1	850	1560	1795	1950	2080	3885	3920	4075	4205	375	1000	6.07	6.45	6.71	6.92	
			2	850	1920	2100	2100	2100	6175	6355	6355	6355	375	1000	5.08	5.23	5.23	5.23	
			3	850	1920	2100	2100	2100	8300	8480	8480	8480	375	1000	4.55	4.65	4.65	4.65	
			4	850	1920	2100	2100	2100	10425	10605	10605	10605	375	1000	4.29	4.36	4.36	4.36	
TBE6	2x6	Douglas Fir Larch	1	935	1820	2095	2275	2425	6975	7250	7430	7580	300	1000	7.44	7.73	7.93	8.09	
			2	935	2220	2555	2735	2735	12535	12870	13050	13050	300	1000	6.68	6.86	6.96	6.96	
			3	935	2220	2555	2735	2735	17690	18025	18205	18205	300	1000	6.29	6.41	6.47	6.47	
			4	935	2220	2555	2735	2735	22845	23180	23360	23360	300	1000	6.09	6.71	6.82	6.90	
		Southern Pine	1	935	1820	2095	2275	2425	6480	6755	6935	7085	300	1000	7.65	7.97	8.18	8.36	
			2	935	2220	2555	2735	2735	11545	11880	12060	12060	300	1000	6.81	7.01	7.11	7.11	
			3	935	2220	2555	2735	2735	16205	16540	16720	16720	300	1000	6.37	6.50	6.58	6.58	
			4	935	2220	2555	2735	2735	20865	21200	21380	21380	300	1000	6.15	6.25	6.31	6.31	
		Spruce-Pine-Fir	1	935	1560	1795	1950	2080	5065	5300	5455	5585	300	965	7.95	8.32	8.55	8.76	
			2	935	1920	2210	2400	2560	8935	9225	9415	9575	300	965	7.01	7.23	7.38	7.51	
			3	935	1920	2210	2400	2560	12440	12730	12920	13080	300	965	6.50	6.66	6.75	6.84	
			4	935	1920	2210	2400	2560	15945	16235	16425	16585	300	965	6.25	6.37	6.44	6.50	
		Hem Fir	1	935	1560	1795	1950	2080	4900	5135	5290	5420	300	965	8.07	8.45	8.70	8.92	
			2	935	1920	2210	2400	2560	8605	8895	9085	9245	300	965	7.08	7.32	7.48	7.61	
			3	935	1920	2210	2400	2560	11945	12235	12485	12645	300	965	6.55	7.32	7.48	7.61	
			4	935	1920	2210	2400	2560	15285	15575	15765	15925	300	965	6.29	6.41	6.49	6.55	

1. Loads are for a pair of TBEs.
2. When truss chord wood species is different than the wall top plate wood species, choose the tabulated allowable loads based on the species with the lower tabulated download capacity.
3. Allowable loads have been increased 60% for wind or earthquake loading with no further increase allowed; reduce where other loads govern.

4. Allowable loads are determined only by nail shear calculations or tests of the metal connectors based on the lowest of 0.125" of deflection or the ultimate load with a 3 times factor of safety. The attached wood members must be designed to withstand the loads imposed by the nails.
5. Perpendicular to Plate loads are reduced for Alternate Installation.
6. Parallel to Plate loads are not reduced for Alternate Installation.
7. Equivalent Top Plate Bearing Width is the actual top plate width (TBE4 = 3½", TBE6 = 5½") plus the enhanced bearing width provided by the TBE.

**TBE** Truss Bearing Enhancers

**ALTERNATE INSTALLATION**

(See illustrations at right)

These products are available with additional corrosion protection. Additional products on this page may also be available with this option, check with Simpson Strong-Tie for details.

Model No.	Alternate Installation Allowable Loads <sup>5,6</sup> Perpendicular to Plate			
	DF/SP (160)		SPF/HF (160)	
	F <sub>2</sub>	F <sub>3</sub>	F <sub>2</sub>	F <sub>3</sub>
TBE4	1000	300	860	260
TBE6				

1. Use full table loads for uplift and parallel-to-plate allowable loads.
2. Download capacities are 0.80 of table loads.
3. See additional footnotes on opposite page.

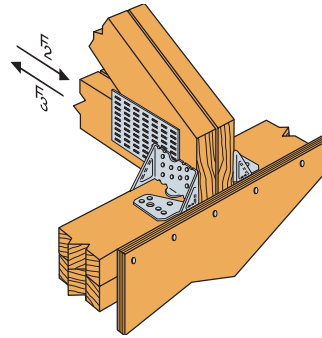

Pre-sheathed shearwall. Bend tab along slot and nail one leg to top of the plate.

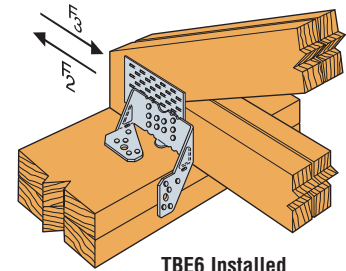

**TBE6 Installed on Double 2x8 Top Plate**

Alternate Installation Allowable Down Loads are 0.80 and Allowable Uplift Loads are 1.0 of the TBE only table loads on page 134.

**TC** Truss Connectors

The TC truss connector is an ideal connector for scissor trusses and can allow horizontal movement up to 1¼". The TC also attaches plated trusses to top plates or sill plates to resist uplift forces. Typically used on one or both ends of truss as determined by the Designer.

**MATERIAL:** 16 gauge **FINISH:** Galvanized

**INSTALLATION:**

- Use all specified fasteners. See General Notes.
- Drive 10d nails into the truss at the inside end of the slotted holes (*inside end is towards the center of the truss*). Do not seat these nails into the truss—allow room under the nail head for movement of the truss with respect to the wall.
- After installation of roofing materials nails may be required to be fully seated into the truss. (*As required by the Designer or Truss Designer.*)

**Optional TC Installation**

- Bend one flange up 90°. Drive specified nails into the top and face of the top plates or install Titen® screws into the top and face of masonry wall. See optional load tables and installation details.

**CODES:** See page 12 for Code Reference Key Chart.

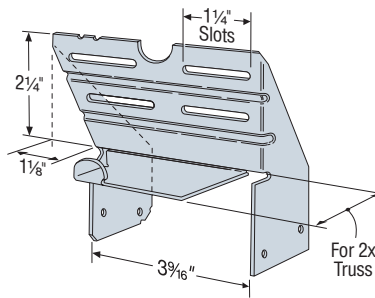

**TC24**  
U.S. Patent 4,932,173

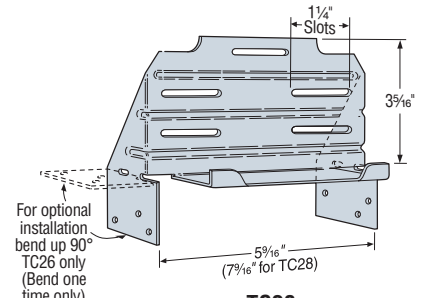

**TC26**  
(TC28 similar)

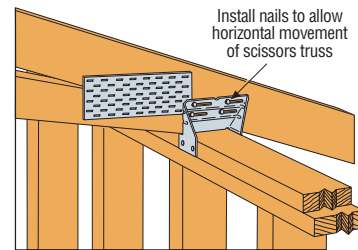

**Typical TC24 Installation**

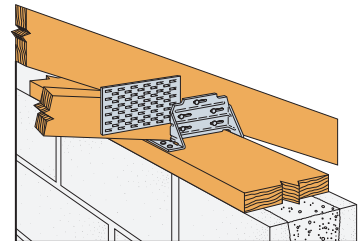

**Optional TC26 Installation for Grouted Concrete Block using a Wood Nailer (8", 10", 12" Wall Installation similar)**

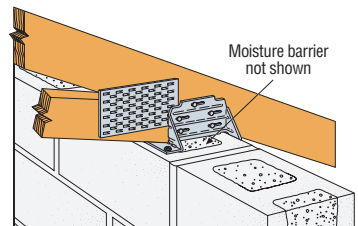

**Optional TC26 Installation for Grouted Concrete Block using Titen Screws**

Model No.	Fasteners		DF/SP Allowable Loads	SPF/HF Allowable Loads	Code Ref.
	Truss	Plate	Uplift (160)	Uplift (160)	
TC24	4-10d	4-10d	600	410	IL14
TC26	5-10d	6-10d	750	550	I13, F12
TC28	5-10d	6-10d	750	550	

See footnotes below.

**OPTIONAL TC INSTALLATION TABLE**

Model No.	Fasteners		DF/SP Allowable Loads	SPF/HF Allowable Loads	Masonry Allowable Loads	Code Ref.
	Truss	Plate	Uplift (160)	Uplift (160)	Uplift (160)	
TC26	5-10dx1½	6-10dx1½	430	350	—	I13, F12
	5-10d	6-10d	450	390	—	
	5-10d	6-3/16x2¼ Titen	—	—	195	

1. Loads have been increased 60% for wind or earthquake loading with no further increase allowed; reduce where other loads govern.
2. Grout strength is 2000 psi minimum.
3. Nail values based on single 2x truss.
4. Optional TC26 installation with 10d nails requires minimum 3" top plate thickness.
5. **NAILS:** 10d = 0.148" dia. x 3" long, 10dx1½ = 0.148" dia. x 1½" long. See page 16-17 for other nail sizes and information.