



TWO LAMP STRIP

IPS-SERIES

(4 FT.)



APPLICATION: This very popular two (2) lamp strip channel is ideally used for applications such as showcases, store windows, valance or cove lighting, workshops, etc. They may be surface-mounted or suspended by chains or rod hangers.

CONSTRUCTION: Made from heavy-duty iron phosphate treated CRS (Cold Rolled Steel) and finished with a high-reflectivity electromagnetic-applied powder coat for a minimum reflectance of 90%, thereby, yielding high lumen efficiency. Die formed for extra strength and rigidity.

ELECTRICAL WIRING: Supplied with a high frequency class "A" sound rating class "P" thermally protected, High Power Factor electronic

ballast with total harmonic distortion of less than 10%. Will operate T8 lamps from 50/60 Hz input source of 120V through 277V. U.L. approved, CBM certified, meets CSA Standards. Complies with U.S.A. National Energy efficiency standards.

ORDERING INFORMATION:

<u>LAMPS</u>	<u>LAMP TYPE</u>	<u>PART NUMBER</u>
2 EA.	17W-T8	IPS-217/MV
2 EA.	25W-T8	IPS-225/MV
2 EA.	32W-T8	IPS-232/MV



TWO LAMP STRIP

IPS-SERIES 4 FT.

CROSS-SECTION

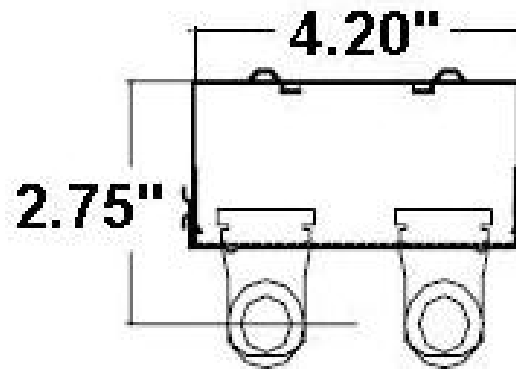

BACKPLAN