



TWO LAMP INDUSTRIAL

IPI-SERIES

(4 FT.)



APPLICATION: Industrial lamp fixtures can be used singularly or in continuous rows, and are ideally suited for industrial applications where reflected light is needed such as machine shops, manufacturing plants, warehouses, etc. They may be surface-mounted or suspended by chains or rod hangers.

CONSTRUCTION: Made from heavy-duty iron phosphate treated CRS (Cold Rolled Steel) and finished with a high-reflectivity electromagnetic-applied powder coat for a minimum reflectance of 90%, thereby, yielding high lumen efficiency. Die formed for extra strength and rigidity.

ELECTRICAL WIRING: Supplied with a high frequency class "A" sound rating class "P" thermally protected, High Power Factor electronic ballast with total harmonic distortion of less than

10%. Will operate T8 lamps from 50/60 Hz input source of 120V through 277V. U.L. approved, CBM certified, meets CSA Standards. Complies with U.S.A. National Energy efficiency standards.

ORDERING INFORMATION:

<u>LAMPS</u>	<u>LAMP TYPE</u>	<u>PART NUMBER</u>
2 EA.	32W-T8	IPI-232/MV

OPTIONAL

<u>LAMPS</u>	<u>LAMP TYPE</u>	<u>PART NUMBER</u>
1 EA.	32W-T8	IPI-132/MV



TWO LAMP INDUSTRIAL IPI-SERIES 4 FT.



CROSS-SECTION

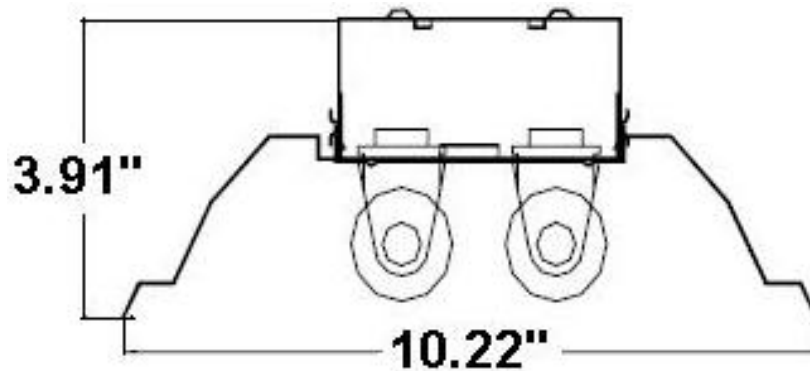

BACKPLAN

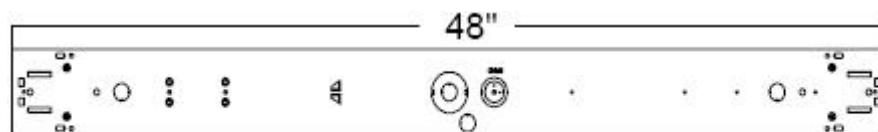

SES 4 FT. BODY