

MODEL RP1 and RP2 Control Panels

Single phase, simplex plug-in pump switch control.

The Model RP control panel provides customers with a reliable means of controlling one 120, 208, or 240 VAC single phase pump in water and wastewater installations. A pump float switch turns the pump on and off. If an alarm condition occurs, an additional alarm float activates the audio/visual alarm system. Common applications include pump chambers, sump pump basins, irrigation systems, and lift stations.

PANEL COMPONENTS

1. **Enclosure** measures 8 x 6 x 4 inch (20.32 x 15.24 x 10.16 cm) with removable mounting feet, NEMA 4X rated, ultraviolet stabilized thermoplastic for indoor and outdoor use.
2. **Alarm Fuse**
3. **Terminal Block**
4. **Red Alarm Beacon** provides 360° visual check of alarm condition.
5. **Alarm Horn** provides audio warning of alarm condition (83 to 85 decibel rating).
6. **Exterior Alarm Test/Normal/Silence Switch** allows horn and light to be tested and horn to be silenced in an alarm condition. **Note:** To place alarm system back into the normal mode after silencing the alarm, the switch must be manually placed into normal mode.
7. **Receptacle** for use with piggy-back pump switch.
8. **Ground Lug** (behind terminal block).

NOTE: Schematic/Wiring Diagram is located inside the panel on enclosure cover.

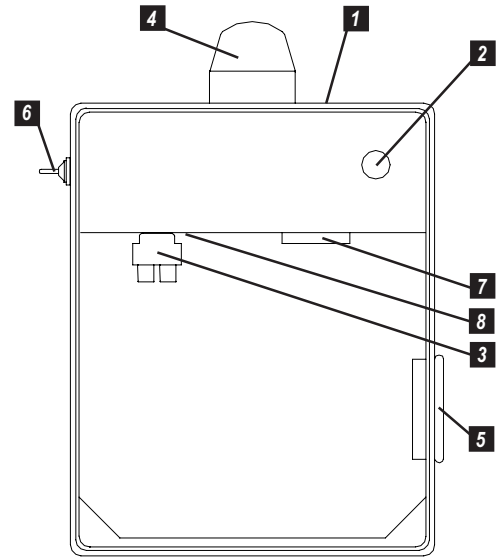

Indoor/Outdoor

PRICING/ORDERING INFORMATION

Model Number	Horsepower/ AC Voltage	Full Load Amps	List Price	Shipping Weight
RP11W510H	1HP/120 VAC	0-15 FLA	\$303.00	10 lbs.
RP21W510H	2HP/208/240 VAC	0-12 FLA	\$314.00	10 lbs.

FEATURES

- Entire control system (panel and switches) is UL Listed to meet and/or exceed industry safety standards
- Dual safety certification for the United States and Canada
- Standard package includes float switches
- Complete with step-by-step installation instructions
- Three-year limited warranty



PO Box 1708, Detroit Lakes, MN 56502
 1-888-DIAL-SJE • 1-218-847-1317
 1-218-847-4617 Fax
 email: sje@sjerhombus.com

www.sjerhombus.com

SEE BACKSIDE FOR COMPLETE LISTING OF AVAILABLE OPTIONS.

RP_ 1 W 1 0

MODEL RP1 OR RP2

MODEL RP1 - 120 VAC	\$ 303.00	
MODEL RP2 - 208/240 VAC	\$ 314.00	
<input checked="" type="checkbox"/> ALARMPACKAGE	Base	
1 = Alarm package (includes test/normal/silence switch, red light, horn and float)	Base	
<input checked="" type="checkbox"/> ENCLOSURERATING	Base	
W = Weatherproof, NEMA 4X (engineered thermoplastic)	Base	
STARTING DEVICE		
<input type="checkbox"/> 2 = SJE PumpMaster® Plus pump switch (0-15 FLA)	-\$10.00	
<input type="checkbox"/> 3 = 120 VAC Double Float® pump switch (0-15 FLA)	\$ 30.00	
<input type="checkbox"/> 4 = 240 VAC Double Float® pump switch (0-12 FLA)	\$ 30.00	
<input type="checkbox"/> 5 = Super Single® pump switch (120V = 0-15 FLA) (208/240V = 0-12 FLA)	Base	
<input type="checkbox"/> 6 = No pump switch	-\$50.00	
<input checked="" type="checkbox"/> PUMP FULL LOAD AMPS	Base	
1 = 0-15 FLA	Base	
<input checked="" type="checkbox"/> PUMP DISCONNECTS	Base	
0 = no pump disconnect	Base	
FLOAT SWITCH APPLICATION		
<input type="checkbox"/> H or L = pump down or pump up	Base	
<input type="checkbox"/> X = no floats	-\$25.00	

OPTIONS *Listed below*

Total Options _____
TOTAL LIST PRICE _____

If additional features are required, call the factory for a quote on an Engineered Custom control panel.

CODE	DESCRIPTION	LIST PRICE
<input type="checkbox"/> 3A	Alarm flasher	\$45.00
<input type="checkbox"/> 10E	Lockable latch	\$20.00
<input type="checkbox"/> 16A	10' cord in lieu of 20' (per float)	-\$2.00
	<i>(Does not apply for Double Float® pump switch)</i>	
<input type="checkbox"/> 16B	15' cord in lieu of 20' (per float)	-\$1.00
<input type="checkbox"/> 16C	30' cord in lieu of 20' (per float)	\$ 5.00
<input type="checkbox"/> 16D	40' cord in lieu of 20' (per float)	\$15.00
<input type="checkbox"/> 17A	SJE SignalMaster® in lieu of Sensor Float®	-\$2.00
	<i>(alarm float only)</i>	
<input type="checkbox"/> 17E	Sensor Float® Mini in lieu of Sensor Float®	-\$2.00
	<i>(alarm float only)</i>	

SAMPLE

MODEL	RP1	1	W	5	1	0	H	3A	
Alarm Package									1 Base
Enclosure Rating									W Base
Starting Device									5 Base
Pump Full Load Amps									1 Base
Pump Disconnect									0 Base
Float Switch Application									H Base
Options: Flasher									3A \$45.00
									TOTAL LIST PRICE \$348.00