

CALIFORNIA EXPANDED METAL PRODUCTS CO.

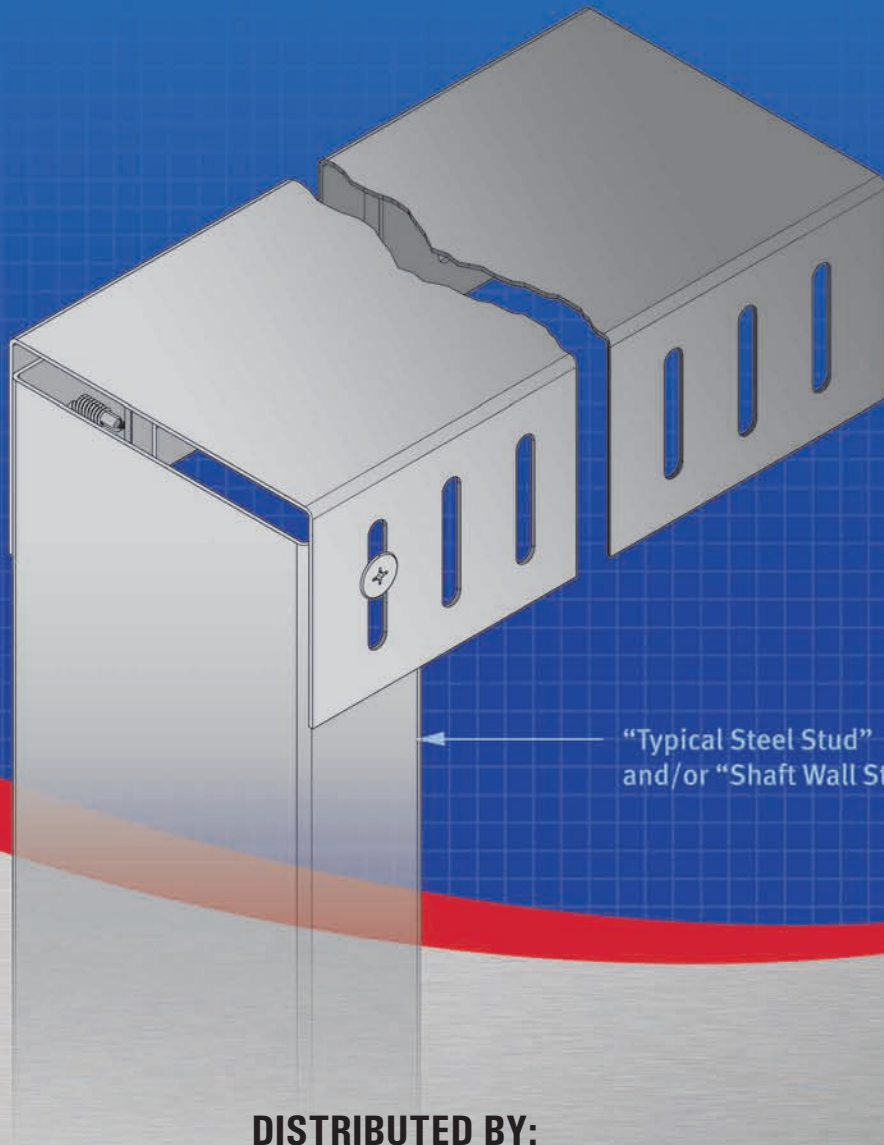

Slotted Track | CST



“Typical Steel Stud”  
and/or “Shaft Wall Stud”

DISTRIBUTED BY:



[www.MarinoWARE.com](http://www.MarinoWARE.com)

# CEMCO Slotted Track (CST)

## About CST

Cold Formed Steel track designed for use at the head of wall which can absorb up to 1" of total vertical movement while providing a positive attachment of the wall framing. The positive attachment allows for greater load resistance with thinner gauges of material. CEMCO slotted is formed from only prime steel conforming to ASTM requirements for Cold Formed Steel.

## Benefits

- One piece design provides easy installation reducing labor and materials
- Code compliance for dynamic head of wall joints
- Allows vertical deflection of the structure
- Protects the Integrity of interior and exterior walls
- No additional strapping, bridging, or clips required
- Eliminates installation/removal of fasteners

- CEMCO slotted integrates into over 200 third-party (UL, WH, ICC-ES) approved design assemblies using a variety of fire stop products to address the head of wall joint including:
  - Firestik
  - Angle mesh with fireproofing
  - Drywall rip attached to angle
  - Stuff and spray sealants

## Code Compliance

CEMCO slotted meets all standard building codes and has been tested at both Underwriter’s Laboratory (UL) and Intertek/Warnock Hersey (WH) certifying that it meets or exceeds the requirements of:

- ASTM E119
- ASTM E814
- ULC S115-M95
- ASTM E1966
- UL 2079



## Unencumbered Assemblies

Capable of 1" Overall Movement

**\$ Labor & Material Saving Solution**

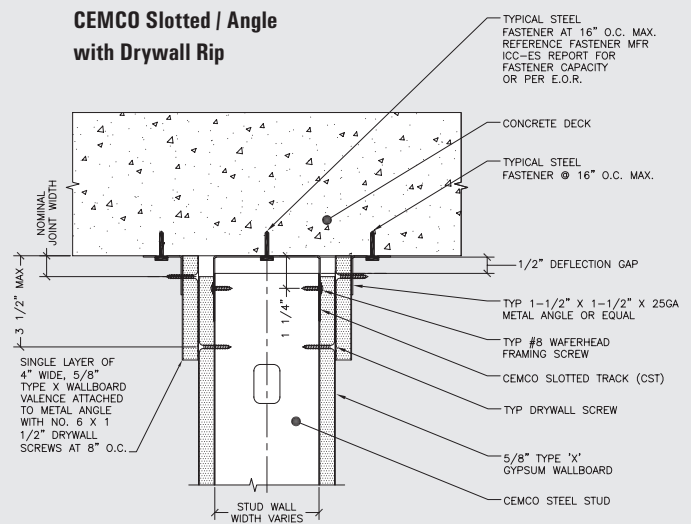
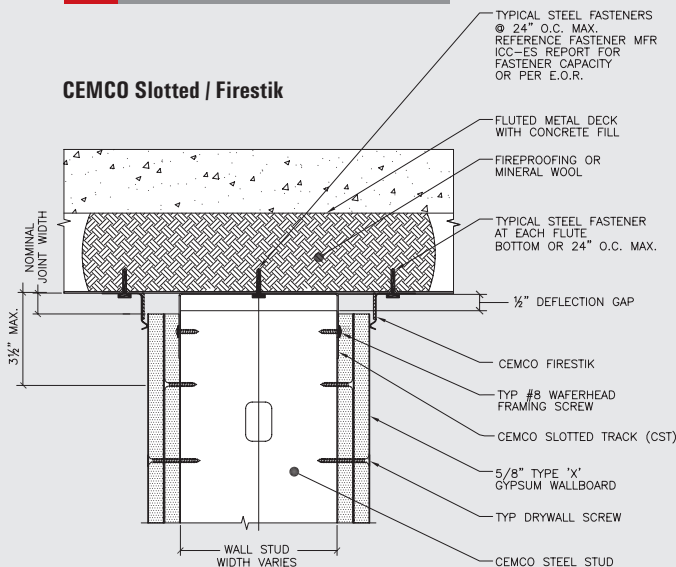

*Details shown in this brochure are examples of actual approved assemblies and listings. Additional assembly details, submittal sheets, and listings are periodically added upon design and approval and can be downloaded or printed from [www.cemcosteel.com](http://www.cemcosteel.com).*

**CST Combined with Various Fire Stop Materials Provides a variety of Detailed Assembly Options**

**Typical Assembly Details**

Assemblies providing **UNENCUMBERED** movement allowing for up to 1" total deflection:

- CEMCO Slotted / Firestik
- CEMCO Slotted / Angle mesh with fire proofing
- CEMCO Slotted / angle with drywall rip

Assemblies experiencing **ENCUMBERED** movement (See UL Fire Resistance Directory for system details and movement limitations):

- CEMCO slotted / stuff and spray (mastic / sealant and mineral wool)

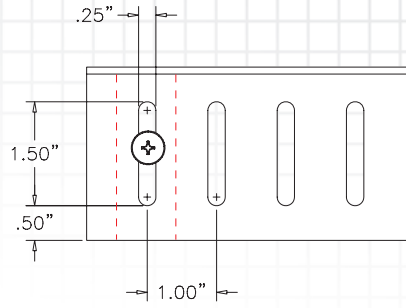

T
20 ga (30 mil)
18 ga (43 mil)
16 ga (54 mil)

W
2-1/2"
3-1/2"
3-5/8"
4"
6"
8"

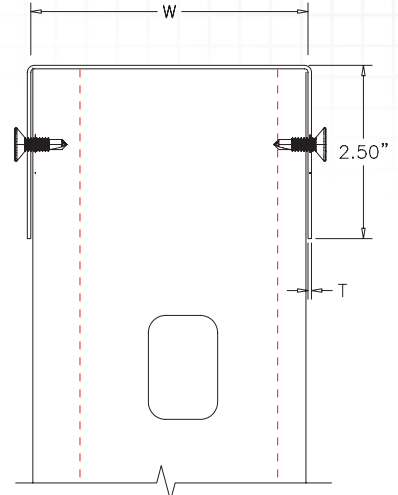

**CEMCO Slotted / Angle Mesh with Fire Proofing**

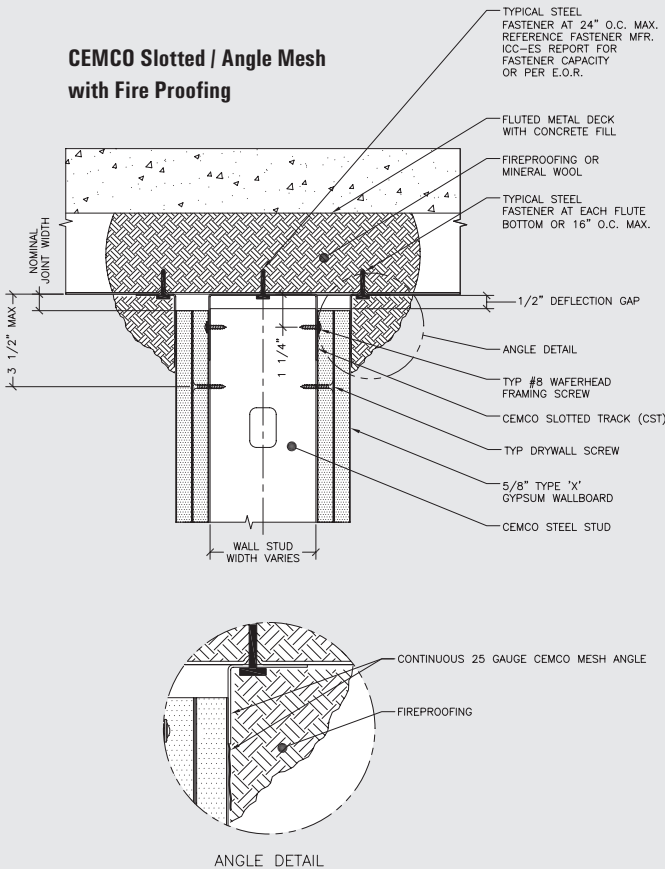

**Encumbered System**

See UL Fire Resistance Directory for Cycle and Movement Capabilities

**CEMCO Slotted / Stuff and Spray (Mastic / Sealant and Mineral Wool)**

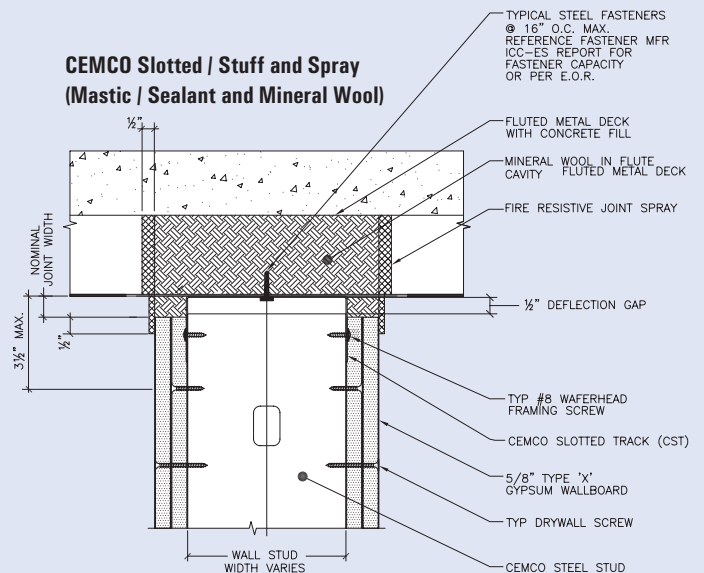



Slotted Track | CST



## Approvals

### ICC-ES Approval

- ESR-2012 – 1 and 2 hour designs – UL 2079 Standard Compliant

### UL Approval

- UL Approved Systems – Fire Stop Manufacturer and Design Number
- UL Control (US) – R25033 – 1 and 2 hour designs – UL 2079 standard compliant
- UL Control (CD) – R25033 – 1 and 2 hour designs – UL 2079 standard compliant

### FireStik

- HW-D-0420 HW-D-0421 HW-D-0453 HW-D-0455 HW-D-0461 HW-D-0462
- HW-D-0463 HW-D-0475 HW-D-0476 HW-D-0475 HW-D-0476 HW-D-0477
- HW-D-0480\* \*(1" deflection shaft wall)

### Rectorseal

- HW-D-0032 HW-D-0033 HW-D-0058 HW-D-0059 HW-D-0104 HW-D-0105
- HW-D-0127 HW-D-0128 HW-D-0129 HW-D-0130 HW-D-0179 HW-D-0180
- HW-D-0221 HW-D-0222 HW-D-0297 HW-D-0298 HW-D-0380 HW-D-0381

### Specified Technologies Inc. (STI)

- HW-D-0003 HW-D-0034 HW-D-0043 HW-D-0044 HW-D-0054 HW-D-0079
- HW-D-0088 HW-D-0099 HW-D-0102 HW-D-0103 HW-D-0136 HW-D-0137
- HW-D-0152 HW-D-0153 HW-D-0194 HW-D-0210 HW-D-0241 HW-D-0242
- HW-D-0243 HW-D-0252 HW-D-0260 HW-D-0363 HW-D-0365 HW-D-0371
- HW-D-0377 HW-D-0456 HW-D-0457

### HILTI

- HW-D-0042 HW-D-0045 HW-D-0046 HW-D-0049 HW-D-0076 HW-D-0077
- HW-D-0082 HW-D-0083 HW-D-0084 HW-D-0085 HW-D-0087 HW-D-0089
- HW-D-0106 HW-D-0154 HW-D-0184 HW-D-0190 HW-D-0209 HW-D-0218
- HW-D-0259 HW-D-0264 HW-D-0292 HW-D-0295 HW-D-0313 HW-D-0321
- HW-D-0322 HW-D-0324 HW-D-0342 HW-D-0388 HW-D-0396

### Passive Fire Protection Partners (PFPF)

- HW-D-0036

### EGS Nelson Firestop

- HW-D-0223 HW-D-0224 HW-D-0227 HW-D-0228 HW-D-0238 HW-D-0239
- HW-D-0283 HW-D-0288 HW-D-0304 HW-D-0305 HW-D-0309 HW-D-0310
- HW-D-0393

### A/D Systems

- HW-D-0247 HW-D-0249 HW-D-0314 HW-D-0315 HW-D-0316 HW-D-0317
- HW-D-0320

### Intertek/Warnock Hersey Approved Systems

- DESIGN NO. CEM/PV 120-01 – FIRESTIK
- DESIGN NO. CEM/PV 120-02 – FIRESTIK
- DESIGN NO. CEM/PV 120-03 – MONOKOTE, ISOLATEK, CAFCO 300
- DESIGN NO. CEM/PV 120-04 – MONOKOTE, ISOLATEK, CAFCO 300

DISTRIBUTED BY:

**MARINO WARE®**

★ **MarinoWARE®**  
**Georgia Plant**  
 777 Greenbelt Pkwy  
 Griffin, GA 30223  
 P: 800.504.8199  
 F: 678.688.1379

★ **MarinoWARE®**  
**New York Sales Office**  
 137 Broadway, Suite B  
 Amityville, NY 11701  
 P: 800.627.4667  
 F: 631.691.1492

★ **MarinoWARE®**  
**Engineering Office**  
 175 Country Club Drive Suite 200A  
 Stockbridge, GA 30281  
 P: 866.545.1545  
 F: 770.507.2605

★ **MarinoWARE®**  
**New Jersey Plant**  
 400 Metuchen Rd  
 South Plainfield, NJ 07080  
 P: 800.627.4661  
 F: 908.412.1442

★ **MarinoWARE®**  
**Indiana Plant**  
 4245 Railroad Ave  
 East Chicago, IN 46312  
 P: 219.378.7100  
 F: 219.378.7106

★ **MarinoWARE®**  
**Texas Plant**  
 10101 Bay Area Blvd.  
 Pasadena, TX 77507  
 P: 800.852.9510  
 F: 281.283.8105