

# Shaftwall and Area Separation Wall Systems

**MARINO** \* **WARE**®

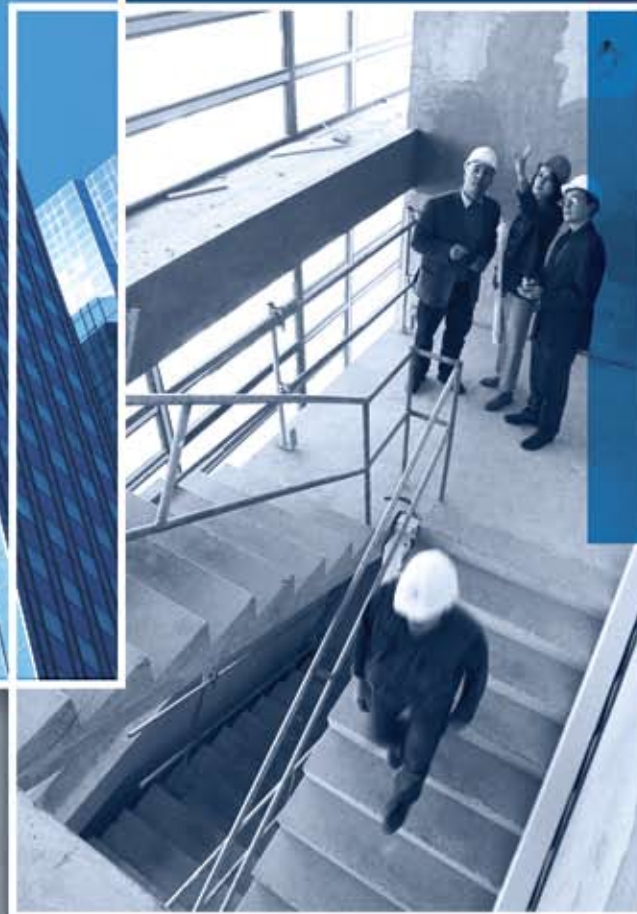

***Marino\WARE'S Fire Rated Wall Systems  
Quality that takes you to the top.***



MarinoWARE created its CT Shaftwall System, to be a flexible shaftwall assembly that can accommodate any UL Classified gypsum liner board for maximum versatility in design, purchase, and construction. The MarinoWARE CT Shaftwall System is comprised of CT-Stud and Tabbed Track components, resulting in easier installation and fewer parts to inventory and purchase.

Plus, the CT System offers all the advantages that customers have come to expect from MarinoWARE.

- Intertek/Warnock Hersey fire-tested
- Full range of sizes: 2 1/2", 4", and 6"
- 25, 20 and 18 gauge engineered for superior performance
- Production in multiple locations, allowing for next day delivery
- One-sided installation, providing faster implementation

|  |       |
|--|-------|
| PRODUCTS: Shaftwall/Stairwall CT Stud, Tabbed Track & Jamb Track       | 2     |
| SPAN CHART: Shaftwall/Stairwall Systems Vertical Span Capacities       | 3     |
| ASSEMBLIES: Shaftwall/Stairwall Design Summary                         | 4     |
| SPAN CHART: Shaftwall Systems Horizontal Span Capabilities             | 4     |
| INSTALLATION: Shaftwall/Stairwall Systems Installation Instructions    | 5     |
| DETAILS: Shaftwall/Stairwall Systems Suggested Construction Details    | 6-7   |
| PRODUCTS: H Stud, C-Runner, Aluminum Breakaway Clip & Assembly Details | 8     |
| ASSEMBLIES: Area Separation Wall Design Summary                        | 9     |
| INSTALLATION: Area Separation Wall Installation Instructions           | 10    |
| DETAILS: Suggested Details for Area Separation Wall System             | 11    |
| SPECIFICATIONS: Architectural Specifications                           | 12-13 |



# PRODUCTS

## 2 Shaftwall/Stairwall CT Stud, Tabbed Track & Jamb Track

### PROPERTY CHART

| Gross Section Properties for CT Studs     |     |       |     |       |  |       |                |                   |                   |
|---|-----|-------|-----|-------|--|-------|----------------|-------------------|-------------------|
| Member                                    | Web | Gauge | Mil | T     | W  | A     | I <sub>x</sub> | S <sub>x(t)</sub> | S <sub>x(b)</sub> |
| 212CT018                                  | 2½" | 25    | 18  | 0.018 | 0.456  | 0.134 | 0.134          | 0.127             | 0.926             |
| 212CT032                                  | 2½" | 20    | 30  | 0.032 | 0.774  | 0.228 | 0.224          | 0.211             | 0.156             |
| 400CT018                                  | 4"  | 25    | 18  | 0.018 | 0.551  | 0.162 | 0.391          | 0.231             | 0.170             |
| 400CT032                                  | 4"  | 20    | 30  | 0.032 | 0.937  | 0.276 | 0.659          | 0.387             | 0.287             |
| 600CT032                                  | 6"  | 20    | 30  | 0.032 | 1.155  | 0.340 | 1.723          | 0.662             | 0.508             |
| 600CT040                                  | 6"  | 18    | 43  | 0.040 | 1.438  | 0.423 | 2.134          | 0.819             | 0.629             |
| T = Design Steel Thickness (inches)       |     |       |     |       | I <sub>x</sub> = Moment of Inertia (inches <sup>4</sup> )                  |       |                |                   |                   |
| W = Weight (pounds per linear foot)       |     |       |     |       | S <sub>x(t)</sub> = Section Modulus 'top' flange (inches <sup>3</sup> )    |       |                |                   |                   |
| A = Sectional Area (inches <sup>2</sup> ) |     |       |     |       | S <sub>x(b)</sub> = Section Modulus 'bottom' flange (inches <sup>3</sup> ) |       |                |                   |                   |

Note: Tabbed Track and Jamb Track available in same size and gauge as CT Studs

CT Stud

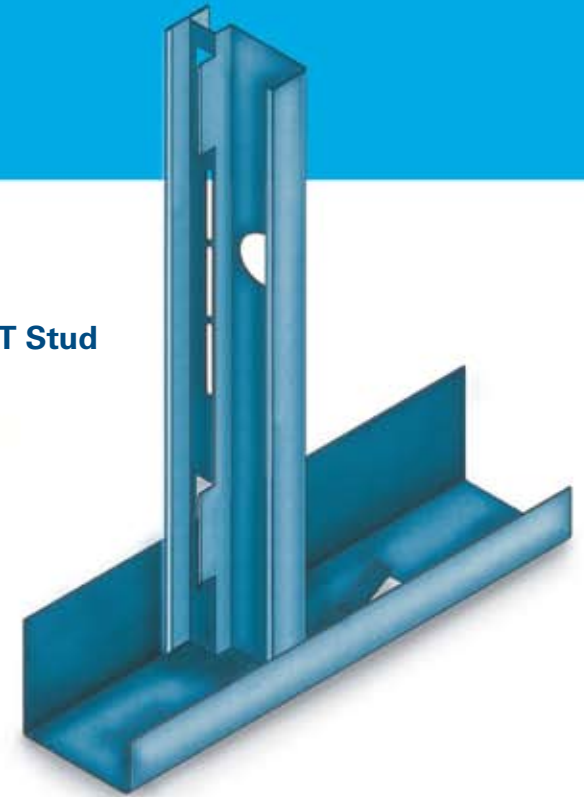

Tabbed Track

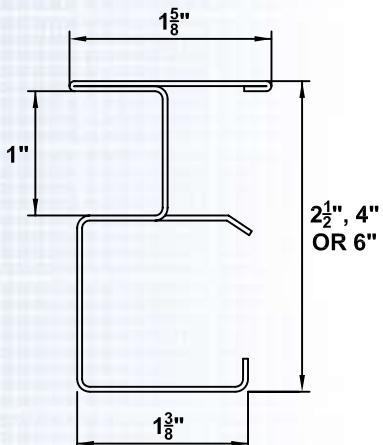

CT STUD

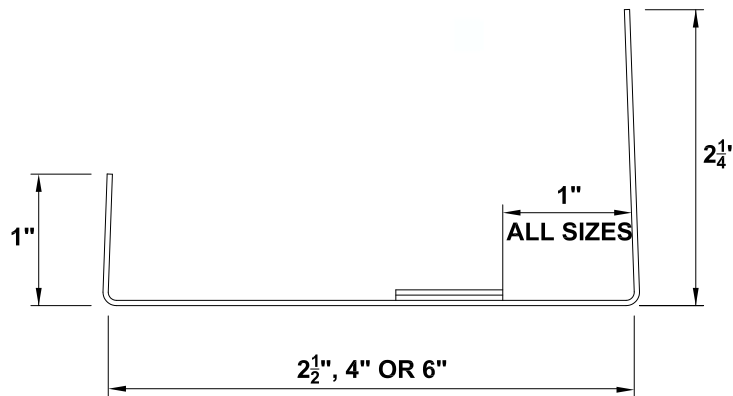

TABBED TRACK

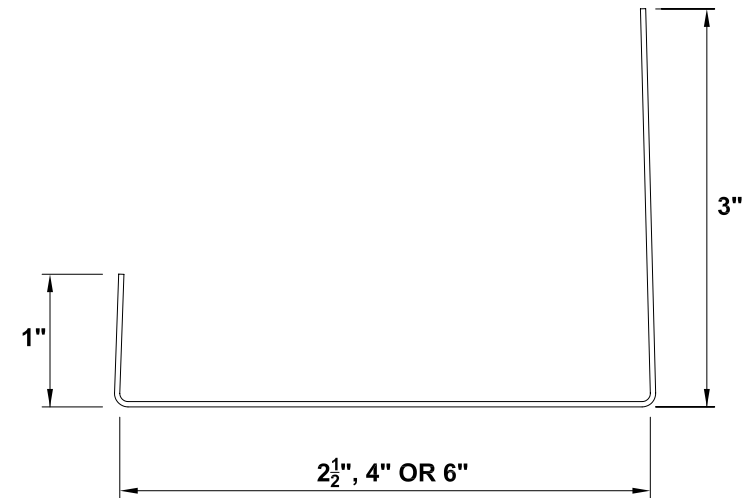

JAMB TRACK

# SPAN CHART

| Limiting Heights for 1 and 2 Hour CT Systems |       |                        |       |                         |  |             |             |             |   |            |             |             |   |           |           |           |
|--|-------|------------------------|-------|-------------------------|--|-------------|-------------|-------------|---|------------|-------------|-------------|---|-----------|-----------|-----------|
| Member Size                                  | Gauge | Design Steel Thickness |       | Design Deflection Limit | Uniform Load (PSF)                             |             |             |             |   |            |             |             |   |           |           |           |
|  |       | (in.)                  | (mil) |                         | For 1 Hour (Shaftwall System)<br>(MW/WA 60-01) |             |             |             | For 2 Hour (Shaftwall System)<br>(MW/WA 120-01) |            |             |             | For 2 Hour (Stairwall System)<br>(MW/WA 120-02) |           |           |           |
|  |       |                        |       |                         | 5  | 7.5         | 10          | 15          | 5   | 7.5        | 10          | 15          | 5   | 7.5       | 10        | 15        |
| 2½"  | 25    | 0.0188                 | 18    | L/120                   | 13'-3" A                                       | 10'-10" A   | 9' - 5" A   | 7' - 8" A   | 14' - 5"  | 12' - 7"   | 11' - 2" A  | 9' - 2" A   | 15'-7"  | 12'-9"    | 11'-0" A  | 9'-0" A   |
|  |       |                        |       | L/180                   | 11'-11"  | 10' - 5"    | 9' - 5"     | 7' - 8" A   | 12' - 7"  | 11' - 0"   | 10' - 0"    | 8' - 9" A   | 13'-8"  | 11'-11"   | 10'-10"   | 9'-0" A   |
|  |       |                        |       | L/240                   | 10'-10"  | 9' - 5"     | 8' - 7"     | 7' - 6"     | 11' - 5"  | 10' - 0"   | 9' - 1"     | 7' - 1"     | 12'-5"  | 10'-10"   | 9'-10"    | 8'-7"     |
|  |       |                        |       | L/360                   | 9'-5"  | 8' - 3"     | 7' - 6"     | 6' - 7"     | 10' - 0"  | 8' - 9"    | 7' - 11"    | 6' - 11"    | 10'-10"   | 9'-5"     | 8'-7"     | 7'-6"     |
| 2½"  | 20    | 0.0346                 | 33    | L/120                   | 17' - 7"                                       | 15' - 5"    | 14' - 0"    | 11' - 11" A | 17' - 0"  | 14' - 10"  | 13' - 6"    | 11' - 9"    | 19'-6" A  | 15'-11" A | 13'-9" A  | 11'-3" A  |
|  |       |                        |       | L/180                   | 15' - 5"                                       | 13' - 5"    | 12' - 3"    | 10' - 8"    | 14' - 10"                                       | 13' - 0"   | 11' - 9"    | 10' - 4"    | 17'-5"  | 15'-3"    | 13'-9" A  | 11'-3" A  |
|  |       |                        |       | L/240                   | 14' - 0"                                       | 12' - 3"    | 11' - 1"    | 9' - 8"     | 13' - 6"  | 11' - 9"   | 10' - 9"    | 9' - 4"     | 15'-10"   | 13'-10"   | 12'-7"    | 11'-0"    |
|  |       |                        |       | L/360                   | 12' - 3"                                       | 10' - 8"    | 9' - 8"     | 8' - 6"     | 11' - 9"  | 10' - 4"   | 9' - 4"     | 8' - 2"     | 13'-10"   | 12'-1"    | 11'-0"    | 9'-7"     |
| 4"   | 25    | 0.0188                 | 18    | L/120                   | 17' - 6" A                                     | 14' - 3" A  | 12' - 4" A  | 10' - 1" A  | 18' - 6"  | 16' - 0" A | 13' - 10" A | 10' - 5" AB | 17'-9" A  | 14'-6" A  | 12'-7" A  | 10'-3" A  |
|  |       |                        |       | L/180                   | 15' - 4"                                       | 13' - 5"    | 12' - 2"    | 10' - 1" A  | 16' - 2"  | 14' - 2"   | 12' - 10"   | 10' - 5" AB | 17'-6"  | 14'-6" A  | 12'-7" A  | 10'-3" A  |
|  |       |                        |       | L/240                   | 13' - 11"                                      | 12' - 2"    | 11' - 1"    | 9' - 8"     | 14' - 8"  | 12' - 10"  | 11' - 8"    | 10' - 2"    | 15'-11"   | 13'-11"   | 12'-7"    | 10'-3" A  |
|  |       |                        |       | L/360                   | 12' - 2"                                       | 10' - 8"    | 9' - 8"     | 8' - 5"     | 12' - 10"                                       | 11' - 3"   | 10' - 2"    | 8' - 11"    | 13'-11"   | 12'-2"    | 11'-0"    | 9'-8"     |
| 4"   | 20    | 0.0346                 | 33    | L/120                   | 21' - 11" A                                    | 17' - 11" A | 15' - 6" A  | 12' - 8" A  | 23' - 8"  | 20' - 8"   | 18' - 9"    | 15' - 11" A | 22'-4" A  | 18'-3" A  | 15'-9" A  | 12'-11" A |
|  |       |                        |       | L/180                   | 19' - 3"                                       | 16' - 10"   | 15' - 3"    | 12' - 8" A  | 20' - 8"  | 18' - 1"   | 16' - 5"    | 14' - 4"    | 22'-4" A  | 18'-3" A  | 15'-9" A  | 12'-11" A |
|  |       |                        |       | L/240                   | 17' - 6"                                       | 15' - 3"    | 13' - 11"   | 12' - 2"    | 18' - 9"  | 16' - 5"   | 14' - 11"   | 13' - 0"    | 20'-8"  | 18'-0"    | 15'-9" A  | 12'-11" A |
|  |       |                        |       | L/360                   | 15' - 3"                                       | 13' - 4"    | 12' - 2"    | 10' - 7"    | 16' - 5"  | 14' - 4"   | 13' - 0"    | 11' - 4"    | 18'-0"  | 15'-9"    | 14'-4"    | 12'-6"    |
| 6"   | 20    | 0.0346                 | 33    | L/120                   | 24' - 6" A                                     | 20' - 0" A  | 17' - 4" A  | 14' - 2" A  | 28' - 10" A                                     | 23' - 6" A | 20' - 5" A  | 16' - 8" A  | 25'-1" A  | 20'-5" A  | 17'-9" A  | 14'-6" A  |
|  |       |                        |       | L/180                   | 24' - 6" A                                     | 20' - 0" A  | 17' - 4" A  | 14' - 2" A  | 28' - 10"                                       | 23' - 6"   | 20' - 5" A  | 16' - 8" A  | 25'-1" A  | 20'-5" A  | 17'-9" A  | 14'-6" A  |
|  |       |                        |       | L/240                   | 24' - 6" A                                     | 20' - 0" A  | 17' - 4" A  | 14' - 2" A  | 26' - 4"  | 23' - 0"   | 20' - 5" A  | 16' - 8" A  | 23'-5"  | 20'-5" A  | 17'-9" A  | 14'-6" A  |
|  |       |                        |       | L/360                   | 22' - 7"                                       | 19' - 9"    | 17' - 4" A  | 14' - 2" A  | 23' - 0"  | 20' - 1"   | 18' - 3"    | 16' - 0"    | 20'-6"  | 17'-11"   | 16'-3"    | 14'-2"    |
| 6"   | 18    | 0.040                  | 40    | L/120                   | 28' - 1" A                                     | 22' - 11" A | 19' - 10" A | 16' - 3" A  | 30' - 0" A                                      | 24' - 6" A | 21' - 2" A  | 17' - 4" A  | 28'-1" A  | 22'-11" A | 19'-11" A | 16'-3" A  |
|  |       |                        |       | L/180                   | 28' - 1" A                                     | 22' - 11" A | 19' - 10" A | 16' - 3" A  | 30' - 0" A                                      | 24' - 6" A | 21' - 2" A  | 17' - 4" A  | 28'-1" A  | 22'-11" A | 19'-11" A | 16'-3" A  |
|  |       |                        |       | L/240                   | 27' - 10"                                      | 22' - 11" A | 19' - 10" A | 16' - 3" A  | 28' - 7"  | 24' - 6" A | 21' - 2" A  | 17' - 4" A  | 26'-0"  | 22'-9"    | 19'-11" A | 16'-3" A  |
|  |       |                        |       | L/360                   | 24' - 3"                                       | 21' - 3"    | 19' - 3"    | 16' - 3" A  | 25' - 0"  | 21' - 10"  | 19' - 10"   | 17' - 4" A  | 22'-9"  | 19'-10"   | 18'-0"    | 15'-9"    |

Notes:  
 A - Shows allowable heights determined by the ultimate load.  
 B - Shows allowable heights calculated to meet required end bearing capacity factor of safety.

# ASSEMBLIES

## 4 Shaftwall/Stairwall Design Summary

### 1 HOUR SHAFTWALL ASSEMBLY

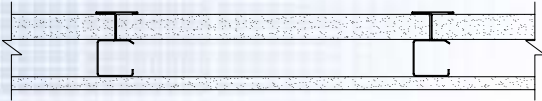

#### Fire Components:

- Any UL Classified 1" thick Liner Board Type X,
- Marino\WARE CT Stud and Tabbed Track
- Any UL Classified of one layer of 5/8" Type X or 1/2" Type C gypsum wallboard, oriented vertically.

#### Sound Rating (STC):

- 2 1/2" CT = 38/41
- 4" CT = 41/47
- 6" CT = 44/48

### 2 HOUR SHAFTWALL ASSEMBLY

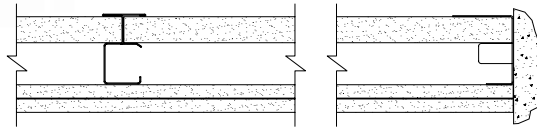

#### Fire Components:

- Any UL Classified 1" thick Liner Board Type X,
- Marino\WARE CT Stud and Tabbed Track
- Any UL Classified of two layers of 5/8" Type X or 1/2" Type C gypsum wallboard, oriented vertically.

#### Sound Rating (STC):

- 2 1/2" CT = 41/46
- 4" CT = 44/49
- 6" CT = 46/49

### 2 HOUR STAIRWALL ASSEMBLY

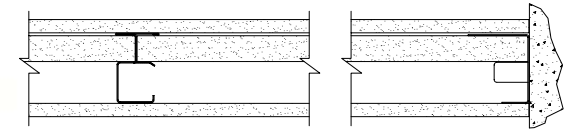

#### Fire Components:

- Any UL Classified 1" thick Liner Board Type X,
- Marino\WARE CT Stud and Tabbed Track
- Any UL Classified of two layers of 5/8" Type X or 1/2" Type C gypsum wallboard, oriented vertically.

#### Sound Rating (STC):

- 2 1/2" CT = 40/45
- 4" CT = 45/49
- 6" CT = 45/50

Note first STC # is the standard fire assembly. The second number represents the same assembly with the addition of 1 1/2" of blanket insulation installed in the cavity.

## Shaftwall Systems Horizontal Span Capacities

Maximum Horizontal Span (ft) (Dead Load Only)

| Member Size | Gauge | Design Steel Thickness |       | MW/WA 60-01 – 1 Hour Shaftwall |          |          |          | MW/WA 120-01 – 2 Hour Shaftwall |           |           |          |
|-------------|-------|------------------------|-------|--------------------------------|----------|----------|----------|---------------------------------|-----------|-----------|----------|
|             |       | (in.)                  | (mil) | L/120                          | L/180    | L/240    | L/360    | L/120                           | L/180     | L/240     | L/360    |
|             |       | 2 1/2"                 | 25    | 0.0188                         | 18       | 12' - 2" | 11' - 4" | 10' - 3"                        | 9' - 0"   | 10' - 9"  | 10' - 9" |
| 2 1/2"      | 20    | 0.0346                 | 33    | 16' - 7"                       | 14' - 6" | 13' - 2" | 11' - 6" | 14' - 7"                        | 12' - 9"  | 11' - 7"  | 10' - 2" |
| 4"          | 25    | 0.0188                 | 18    | 13' - 3"                       | 13' - 3" | 13' - 2" | 11' - 6" | 10' - 8"                        | 10' - 8"  | 10' - 8"  | 10' - 8" |
| 4"          | 20    | 0.0346                 | 33    | 19' - 1"                       | 17' - 7" | 16' - 5" | 14' - 4" | 20' - 3"                        | 17' - 8"  | 16' - 1"  | 14' - 0" |
| 6"          | 20    | 0.0346                 | 33    | 23' - 2"                       | 21' - 3" | 20' - 0" | 18' - 6" | 24' - 7"                        | 22' - 11" | 21' - 10" | 19' - 8" |
| 6"          | 18    | 0.040                  | 40    | 24' - 5"                       | 22' - 4" | 21' - 1" | 19' - 5" | 24' - 5"                        | 23' - 10" | 22' - 7"  | 21' - 1" |

# INSTALLATION

- 1 Lay out per construction drawings. Secure Tabbed Track as perimeter framing on floor and plumb to ceiling and sides. Attach with suitable fasteners, spaced not more than 24" o.c.
- 2 Plan the stud layout 24" o.c. and adjust the spacing at either end so that the terminal stud will not fall closer than 8" from the end.
- 3 Erect the first 1" Liner Board panel, cut  $\frac{3}{4}$ " less than the total height of the framed section. Plumb the panel flush against the web of the Tabbed Track and secure with 1-5/8" Type S screws 24" o.c. or bend out tabs in Tabbed Track to secure panels in place.
- 4 Insert a Marino\WARE CT Stud, cut  $\frac{3}{4}$ " less than the overall height, into the top and bottom Tabbed Tracks and fit tightly over the previously installed 1" panel.
- 5 Install the next 1" Liner Board panel inside the Tabbed Tracks and within the tabs of the CT Stud. Note that the edges of the panel may be beveled to help guide the panel into the slotted and tabbed section of the stud.
- 6 Progressively install succeeding studs and panels as described above until the wall section is enclosed. The final panel section may be secured with 1-5/8" Type S screws or tabs from the Tabbed Track at 24" o.c.
- 7 For doors, ducts or other large penetrations or openings, install Jamb Track as perimeter framing. Use 20-gauge track with a 3" back leg for elevator doors and block cavity with 12" wide gypsum board filler strips when required by Door Frame Manufacturer.
- 8 1" Liner Board panels may be abutted, spliced or stacked within the cavity. The shorter panel should be minimum 2" long or longer to engage two stud tabs on each panel edge. Joints of adjacent panels should be alternately stacked or staggered to prevent a continuous horizontal joint. NOTE: Fire tests were conducted without back blocking of Liner Board joints.
- 9 Finished one side system. Install the first layer of 1/2" UL Classified gypsum board horizontally with 1" Type S or S-12 screws spaced 24" o.c. (5/8" Type X gypsum board may be used in lieu of 1/2" Type C gypsum board, if desired). The horizontal joints should be offset from any splice joints in the Liner Board panels by at least 12". The face layer may be installed either horizontally or vertically with 1-5/8" Type S or S-12 screws spaced 8" o.c. All edge and end joints should be offset from the base layer by 24" o.c.
- 10 Finished both sides system. Each side may be installed either horizontally or vertically with 1" Type S or S-12 screws spaced 8" o.c. Offset edges and ends on opposite sides 24" o.c.
- 11 When used as HVAC ducts, consult with HVAC engineer regarding level of caulking and sealant required. All joints on face layers are to be taped and finished and fasteners finished with joint compound meeting ASTM C 475. All penetration openings are to be filled with approved fire stopping sealants.

# DETAILS

6

## Shaftwall/Stairwall Systems Suggested Construction Details

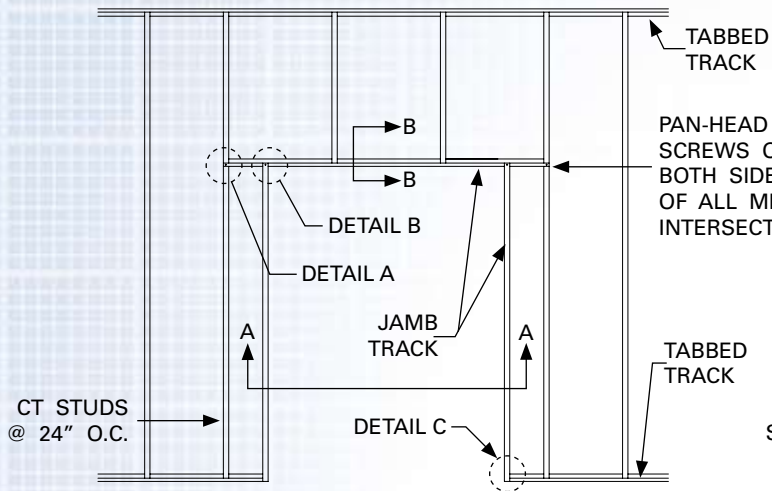

1 DOOR FRAME ELEVATION

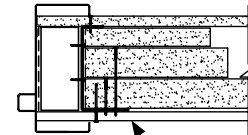
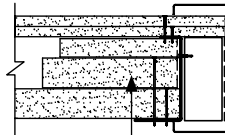
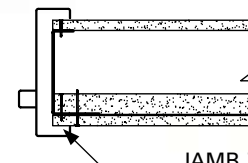
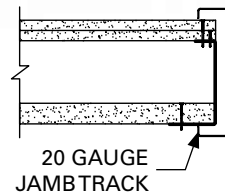

SOLID GYPSUM FILLER STRIPS AS REQUIRED FOR DOOR FRAMES

2 JAMB DETAIL SECTION A-A

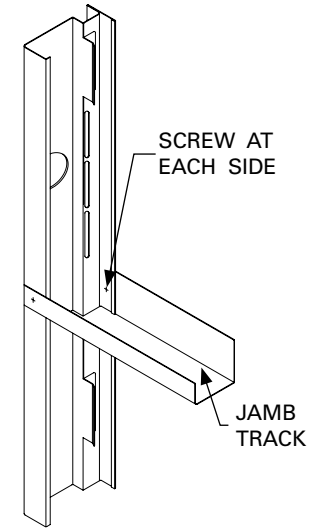

3 HEADER DETAIL DETAIL A

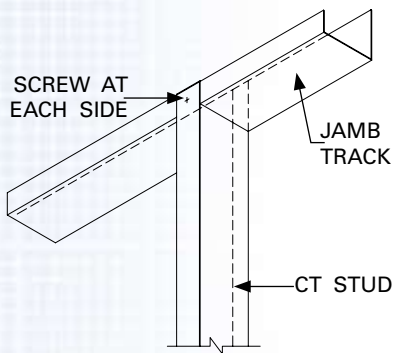

4 HEADER DETAIL DETAIL B

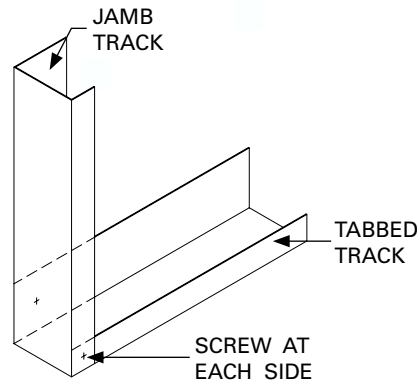

5 JAMB DETAIL DETAIL C

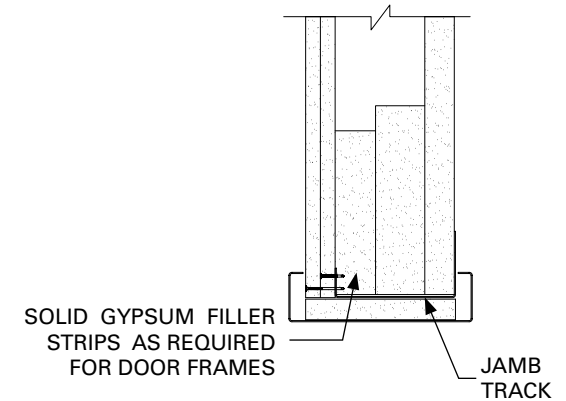

6 HEADER DETAIL SECTION B-B



# DETAILS

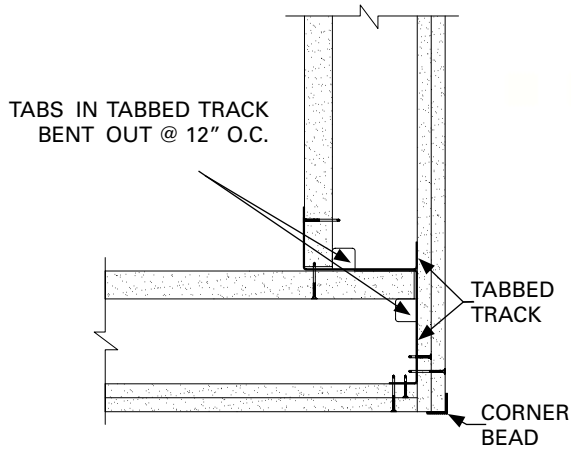

7 OUTSIDE CORNER DETAIL

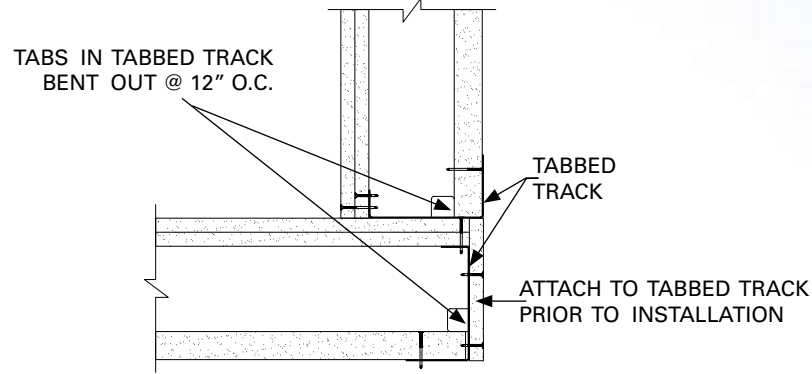

8 INSIDE CORNER DETAIL

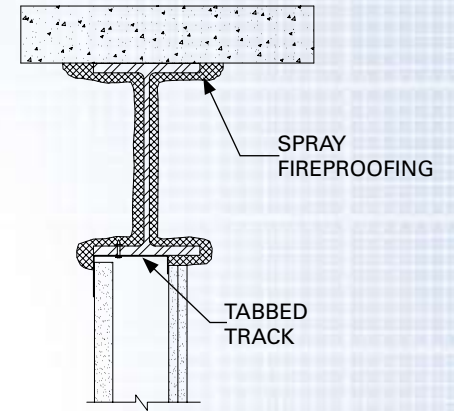

9 STEEL BEAM DETAIL

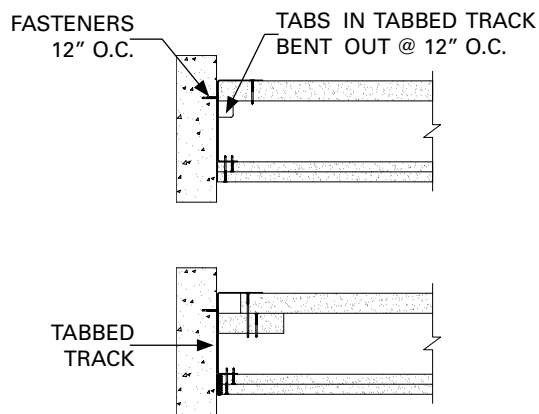

10 END OF WALL DETAIL

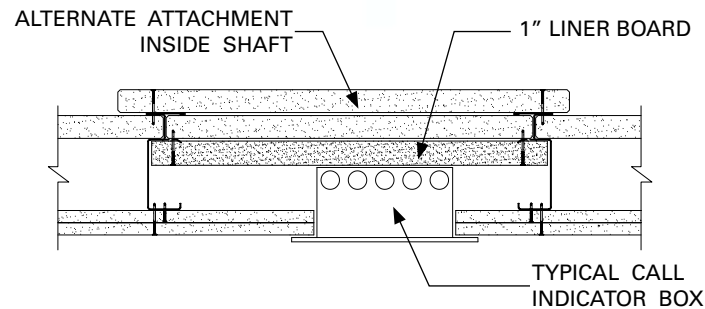

11 CALL BOX/OUTLET BOX/MAIL CHUTE

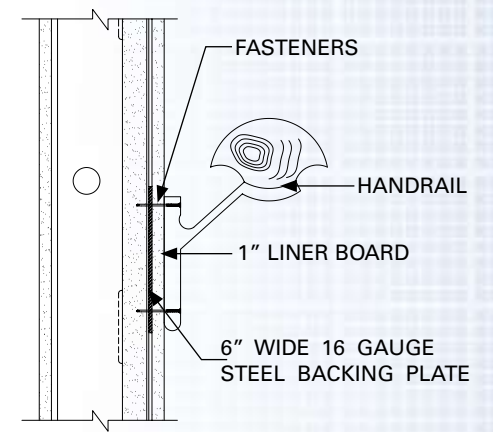

12 HANDRAIL CONNECTION

# PRODUCTS

## 8 H-Stud, C-Runner, Aluminum Breakaway Clip & Assembly Details

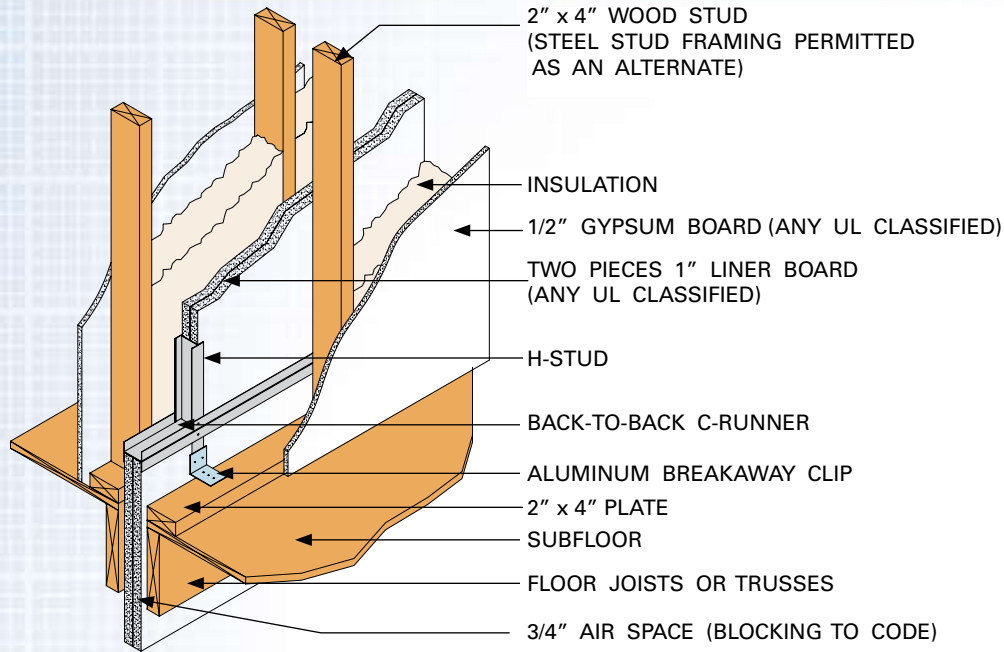

**Wall Section Assembly**

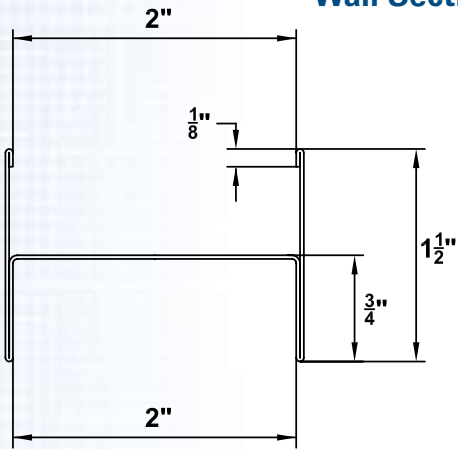

**H STUD**



**C RUNNER**

**H-Stud**

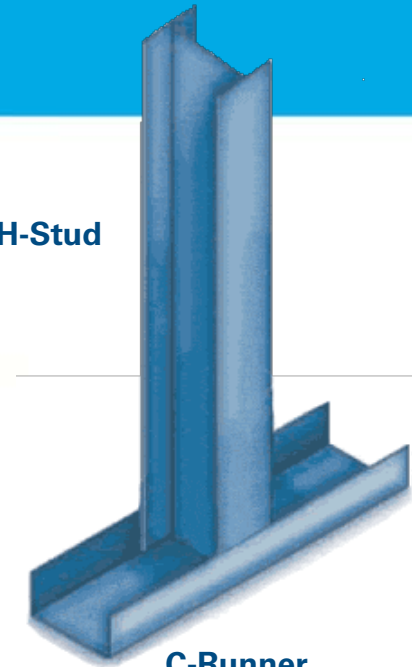

**C-Runner**

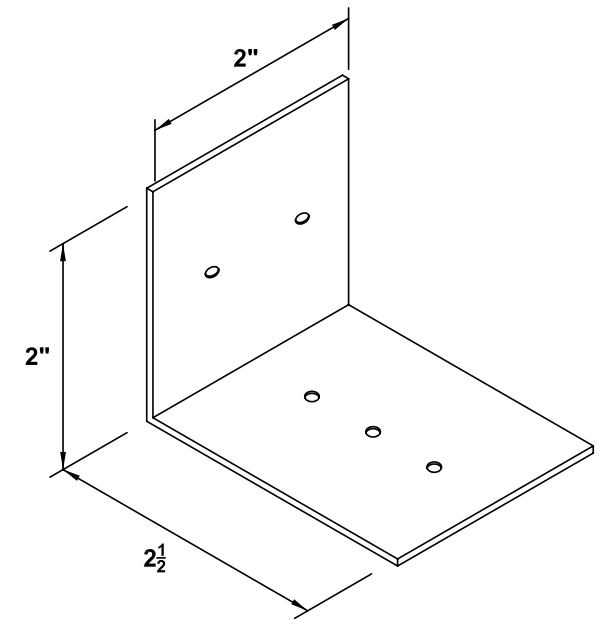

**ALUMINUM BREAKAWAY CLIP**

# ASSEMBLIES

## 2 HOUR NON-BEARING AREA SEPARATION WALL ASSEMBLY

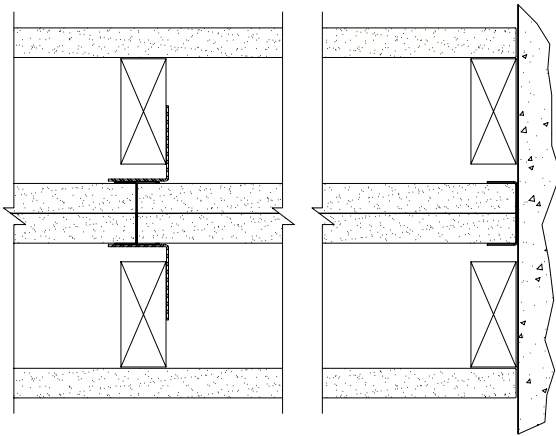

## 2 HOUR NON-BEARING AREA SEPARATION WALL ASSEMBLY

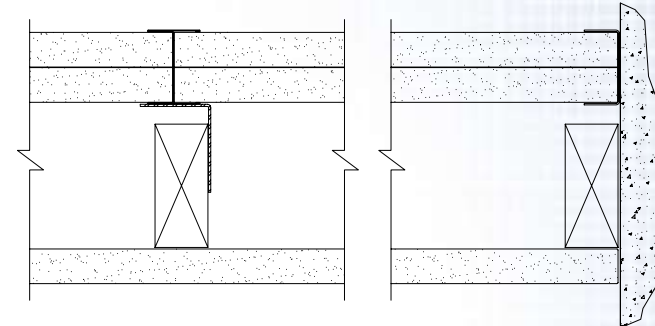

**Test Reference: WHI Design No. MW/WA 120-03**

### Fire Components:

- Any UL Classified 1/2" gypsum wallboard, oriented vertically or horizontally to wood framing. One (1) layer each side of assembly.
- Wood Framing - Nominal: 2" x 4" wood framing, spaced 24" oc maximum and spaced 1/2" from shaftwall surface  
-OR-
- Steel Framing - Bearing: 3-1/2" min. depth x 1-5/8" min. flange x 0.0346" min. gauge, spaced 24" oc maximum and 1/2" from shaftwall surface.
- Steel Framing - Non Bearing: 3-1/2" min. depth x 1-1/4" min. flange x 0.0179" min. gauge, spaced 24" oc maximum and 1/2" from shaftwall surface.
- 2" long aluminum breakaway clip attached to wood framing.
- Any UL Classified 1" Type X Gypsum Linear boards. Two boards back-to-back are inserted against the web of the track and into the recess of the studs.
- Marino\WARE H Stud – 2", 25 Gauge .0179" (18 mil) – 33 ksi

# INSTALLATION

## 10 Area Separation Wall Installation Instructions

The Marino\WARE Area Separation Wall is constructed once the framing for one multistory unit is complete and prior to the construction of the interior framing on the adjacent unit. The area separation wall is constructed a minimum 3/4" away from the adjacent framing, which is typically constructed from wood. In many cases the area separation wall is positioned 1" away from the wall framing to accommodate the 1" Liner Board panels used as fire blocking between the floor levels.

### Erecting the 2" Area Separation Wall

- 1 Position 2" Marino\WARE C Runner a minimum 3/4" from the framed wall of the adjacent unit. Fasten C Runner to foundation with power-driven fasteners spaced a maximum of 24" o.c. When specified, apply a minimum 1/4" bead of acoustical sealant under the C Runner to maximize acoustical privacy. Run the C Runner to the end of the foundation. In the case of offset units, run the C Runner to the end of the offset unit.
- 2 Install Marino\WARE H Studs and 1" Liner Board to a maximum height of 2' above the first floor line. Install two 1" Liner Board panels vertically into the C Runner at one end of the wall. Install the H Stud over the double beveled edges of the Liner Board panels and continue alternately until the wall has reached the opposite end of the foundation. Terminate the wall using a C Runner. The vertical C Runners at each end of the wall should be attached in the corners to the horizontal sections of C Runner using a 3/8" pan head screw.
- 3 Cap the first section of the area separation wall with a C Runner and attach to the vertical C Runner in the corners using a 3/8" pan head screw. An H Stud may also be used to cap the wall.

- 4 Aluminum breakaway clips span the minimum 3/4" airspace and provide a fusible link between the H Studs and the adjacent wall framing. Attach the aluminum breakaway clips to the flange of the H Stud using one 3/8" pan head screw and to the adjacent wood framing using one 1" drywall screw. The aluminum breakaway clips are typically located vertically at each floor level (10' - 0" o.c.) and horizontally on every H-Stud (24" o.c.). When the total height of the area separation wall exceeds 20' - 0", aluminum breakaway clips shall be installed every 5' - 0" for the lower 20' - 0" and every 10' - 0" for the upper 30' - 0" of the wall assembly. Aluminum breakaway clips are installed on both sides of the area separation wall.
- 5 Fire blocking is installed on both sides of the area separation wall at each floor level as defined in Section 717.2.1 of the 2003 IBC.
- 6 To continue the wall, install a C Runner over the C Runner used to cap the lower section, placed back to back and attached together with 3/8" pan head screws spaced 24" o.c. This is not applicable if an H-Stud is used to link the sections of wall.
- 7 The support walls located adjacent to, and on each side of the solid 2" area separation wall, protect and maintain the required 3/4" air space. These support walls offer increased acoustical privacy and provide necessary aesthetics. They can be designed as load bearing. These walls can readily accommodate code compliant electrical and plumbing systems. These systems should not impede the required 3/4" air space. Apply acoustical sealant around penetrations for maximum acoustical privacy.
- 8 Once the 2" area separation wall is erected, construction of the adjacent interior wall framing can begin. Aluminum Breakaway clip and fire blocking installation is identical for both sides of the 2" area separation wall.

## FULL WALL DETAIL

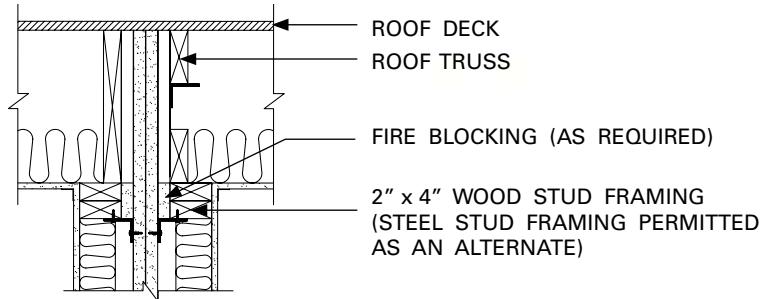

INTERSECTION AT ROOF

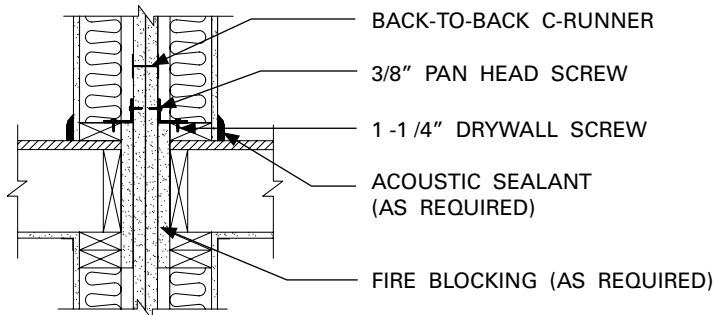

INTERMEDIATE FLOOR

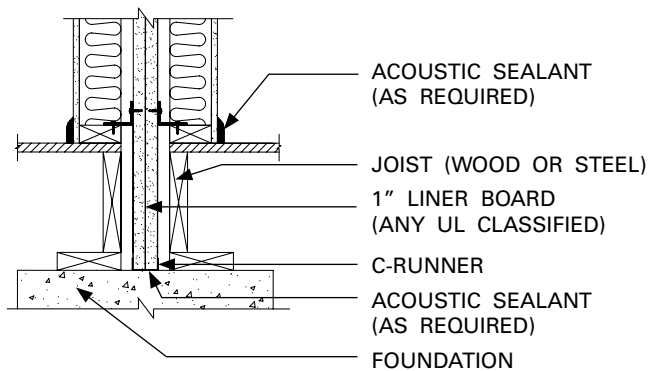

## INTERMEDIATE FLOOR DETAIL

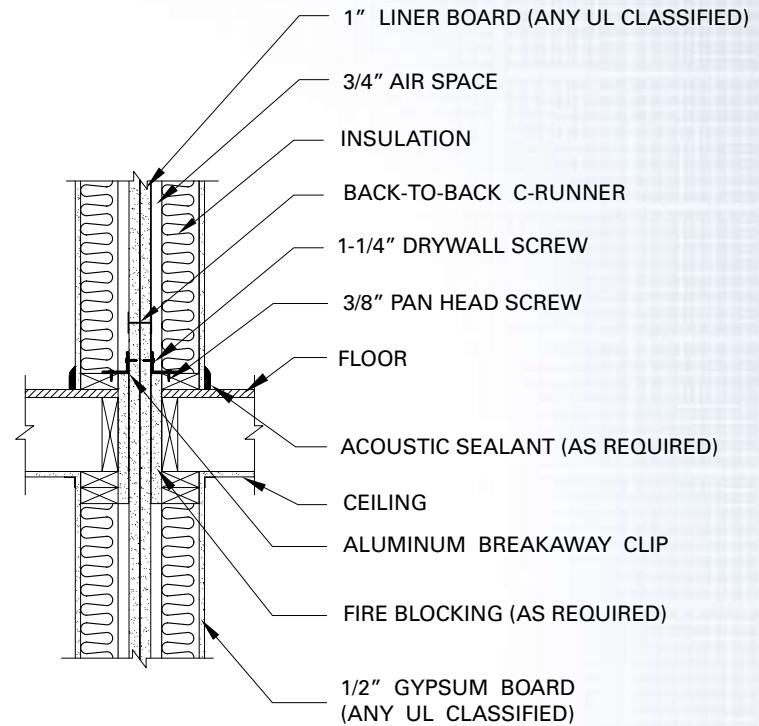

# SPECIFICATIONS

## 12 Architectural Specifications

### Part 1 – General

---

#### 1.0 Description of Work

Types of Work: The types of work herein specified include, but are not limited to, CT Shaftwall, CT Stairwall and H-Stud Area Separation Wall System.

#### 1.1 Quality Assurance

- A. Fire Resistance Ratings: Where shaftwall/stairwall systems with fire resistance ratings are indicated, provide UL Classified Liner Board.
- B. Provide fire resistance rated assemblies identical to those indicated by reference to WHI (Warnock Hersey International) numbers or in listing of other testing agencies acceptable to authorities having jurisdiction.

#### 1.2 Qualifications

All shaftwall/stairwall framing materials shall be manufactured by Marino\WARE. All materials shall be installed in accordance with printed installation instructions as required by the testing agency.

#### 1.3 Submittals

Product Data: Submit Marino\WARE's descriptive literature for each shaftwall/stairwall and Area Separation Wall component indicating materials, dimensions, and other data required to show compliance with the specifications.

#### 1.4 Delivery, Storage and Handling

- A. Deliver materials in original packages, containers or bundles bearing Marino\WARE's brand name and identification.

- B. Store materials level, inside, under cover. Keep materials dry and protect from weather and damage from construction operations and other causes.
- C. Handle system components to prevent damage to edges, ends or surfaces. Protect metal accessories, framing and trim from bending and damage.

### Part 2 – Products

---

#### 2.0 Materials

- A. Metal framing:
  1. CT Studs:
    - a. Galvanized steel, conforming to ASTM C 645 manufactured by Marino\WARE.
    - b. Width: 2½", 4" and 6"
    - c. Gauge: 18, 20 and 25 (40 ksi)
  2. Tabbed Track and Jamb Track:
    - a. Galvanized steel, conforming to ASTM C 645 manufactured by Marino\WARE.
    - b. Width: 2½", 4" and 6"
    - c. Gauge: 20 at elevator doors and masonry cavities and 25 standard elsewhere. (40 ksi)
  3. H Stud and C Runner:
    - a. Galvanized steel, conforming to ASTM C 645 manufactured by Marino\WARE.
    - b. Width: 2"
    - c. Gauge: 25 (33 ksi)
    - d. Mill: 18
- B. Fasteners: For 25-gauge framing – Type S screws. For 20-gauge framing – Type S-12 screws.

### Part 3 – Execution

---

#### 3.0 Installation

- A. General: Follow Marino\WARE recommendations for installation of metal framing.

#### 3.1 Installation of Framing (Shaftwall/Stairwall)

- A. Installation of Tabbed Track, CT Studs and 1" Liner Board panels.
  1. Lay out shaftwall in locations indicated on construction drawings.
  2. Anchor Tabbed Track perimeter framing at abutting horizontal and vertical construction.
  3. Anchor with approved fasteners spaced maximum 24" o.c.
  4. Apply non-hardening, flexible sealant in a continuous application at the perimeter.
  5. Space CT Studs at 24" o.c. Adjust the spacing at ends of shaftwall construction so end studs are minimum 8" from the ends.
  6. Install the first Liner Board panel. The panel length shall be ¾" less than the total height of the framed section. Plumb the panel against the web of the Tabbed Track and bend out tabs in Tabbed Track to secure the panel in place.
  7. Insert a CT Stud into the top and bottom Tabbed Track and fit tightly over the previously installed 1" panel. Allow equal clearance between track and stud at top and bottom Tabbed Track. The stud length shall be ¾" less than the total height of the framed section.
  8. Install the second 1" Liner Board panel inside the Tabbed Track and within the tabs of the CT Studs.

9. Install succeeding studs and panels in the same manner as described for the first and second panels until the wall section is complete.
10. Anchor the final panel section at 12" o.c. with tabs from the Tabbed Track.
11. Where wall heights exceed the standard or available length of the Liner Board panels, the panels shall be cut and stacked with joints occurring within the top or bottom third of the wall height. The shorter panels shall be minimum 24" long and of sufficient length to engage 2 studs.
12. For doors, ducts or other large penetrations or openings, install Jamb Track as perimeter framing. Use 20-gauge track with a 3" back leg for elevator doors and block cavity. Install 12" wide gypsum filler strips for doors exceeding 7'-0" height.

### 3.2 Installation of Framing (Area Separation Wall)

1. Foundation: Position 2" C-Runner at floor and attach securely to foundation at ends and 24" o.c. Caulk under runner at foundation with min. 1/4" bead of acoustical sealant when specified to reduce noise transmission.
2. First Floor: Install H-Studs and insert Liner Board. Attach two thicknesses of 1" Liner Board vertically in C-Runner with long edges in H-Stud. Continue installing H-Studs and Liner Board alternately until wall is complete. Attach horizontal C-Runner to top of Liner Board, fastening flanges of C-Runner at all corners on both sides of Liner Board with 3/8" drill point screws.
3. Intermediate Floors: Attach C-Runner to C-Runner cap on wall below, staggering end joints at least

12". Fasten C-Runner together using double 3/8" screws at ends and 24" o.c. Fasten H-Studs to adjacent framing with aluminum breakaway clips. Attach breakaway clips to H-Stud with one 3/8" drill point screw and to adjacent wood framing with 1 1/4" drywall screw. Install fire blocking between solid wall system and adjacent framing at floor lines, bottom of truss line and any other locations according to code requirements.

4. Roof: Cut Liner Board and H-Studs to follow roof pitch. Fasten H-Studs to framing with an aluminum breakaway clip.

### 3.3 Installation of Gypsum Board

- A. Shaftwall/Stairwall system finished one side:
  1. Install gypsum board in a double layer on one side, either horizontally or vertically.
  2. Install the first layer of gypsum board horizontally with approved fasteners spaced 24" o.c. and 3" from all edges.
  3. Offset the horizontal joints minimum 12" from any splice joints in the Liner Board panels.
  4. Install the face layer of gypsum board parallel to the framing with approved fasteners spaced minimum 12" o.c. and 6" from all edges.
  5. Offset edge and end joints from the base layer at least 24".
- B. Stairwall/Stairwall System, Finished Both Sides:
  1. Install gypsum board on both sides, either horizontally or vertically.
  2. Attach gypsum board with approved fasteners spaced 12" o.c. and 6" from all edges.

3. Offset edges and ends of gypsum board on opposite sides minimum 24".

### 3.4 Finishing

- A. Apply a non-hardening, flexible sealant continuous at all perimeter edges, abutments with dissimilar materials and penetrations in the facing layer.
- B. Tape and finish all joints at face layers with tape and joint compound and finish fastener heads with joint compound meeting ASTM C 475.

### 3.5 Protection of Work

- A. Protect shaftwall work from damage and deterioration until date of substantial completion.
- B. Repair damaged work to be indistinguishable from adjacent work. Replace work that cannot be repaired as required.

#### Limitations:

- Non-load-bearing; not to be used as an unlined air supply duct.
- Not designed for exposure to constant high-moisture conditions or direct water.
- Elevator door assemblies require support independent of shaftwall partitions.
- Good construction practice calls for partition control joints to coincide with that of the building structure.
- Limiting loads and heights not to exceed design specifications or data provided herein or by metal component supplier.
- Provide flexible sealant/caulk at partition perimeters and penetrations to avoid air leakage/whistling and dust collection.



M/W 01 - 2009

[www.marinoware.com](http://www.marinoware.com) • [sales@marinoware.com](mailto:sales@marinoware.com) • [technicalservices@marinoware.com](mailto:technicalservices@marinoware.com)

**NEW JERSEY FACILITY**

400 Metuchen Road  
South Plainfield, NJ 07080  
**800-627-4661** Toll-Free  
908-757-9000 Phone  
908-412-1442 Fax

**GEORGIA FACILITY**

777 Greenbelt Parkway  
Griffin, GA 30223  
**800-504-8199** Toll-Free  
678-688-1312 Phone  
678-688-1379 Fax

**INDIANA FACILITY**

4245 Railroad Avenue  
East Chicago, IN 46312  
**866-636-6002** Toll-Free  
219.378.7100 Phone  
219.378.7106 Fax

**TEXAS FACILITY**

10101 Bay Area Boulevard  
Pasadena, TX 77507  
**866-852-9510** Toll-Free  
281-283-8100 Phone  
281-283-8105 Fax

**NEW YORK SALES OFFICE**

137 Broadway, Suite B  
Amityville, NY 11701  
**800-627-4667** Toll-Free  
631-691-2200 Phone  
631-691-1492 Fax

**ENGINEERING OFFICE**

175 Country Club Drive, Suite 200A  
Stockbridge, GA 30281  
**866-545-1545** Toll-Free  
631-691-2200 Phone  
631-691-1492 Fax