



PH15

PAGING HORN

DESCRIPTION

The PH15 is a weather-resistant paging horn designed for indoor or outdoor fixed installations.

The PH15 is supplied with an integral 70/100V line transformer rated to a maximum of 15 watts. Power is adjustable by means of a recessed rotary switch on the back of the horn, and allows selection of 7.5, 3.75, 1.87, 0.94, and OFF for 70.7V operation, and 15, 7.5, 3.75, 1.87, and OFF for 100V operation. A sixth position is provided for low-impedance operation at 15W into 8 ohms.

The paging horn assembly is shipped with an adjustable mounting bracket for easy installation and aiming, and an attached color-coded speaker cable. It is constructed of high-impact ABS plastic with a light grey finish. The PH15 is compliant with European Directives 2002/96/EC (WEEE) and 2002/95/EC (RoHS).



PH15 DIMENSIONS

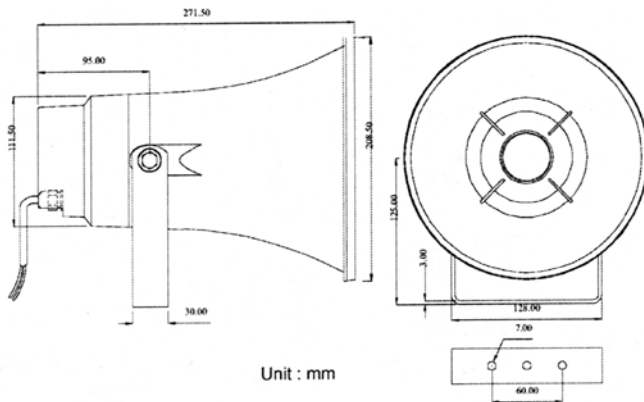

Features

- High-efficiency paging horn
- Weather-resistant to withstand demanding environmental conditions
- Built-in multi-tap constant voltage transformer for 70.7 V or 100 V distributed systems
- Bypass mode for low-impedance operation into 8 ohms
- Lightweight, UV/weather resistant, high-impact ABS plastic construction
- Integrated cable strain relief
- Stainless steel mounting bracket

Applications

- Indoor/Outdoor Voice Paging
- Background Music
- Tone Signaling
- Boats
- Mobile Vehicle
- Security

SPECIFICATIONS

SYSTEM

Freq. Range (-10 dB):	460 Hz-9 kHz
Freq. Range (-20 dB):	300 Hz-11 kHz
Dispersion @ 1 kHz/4 kHz:	110°/30°
SPL (1W):	108 dB @ 1m
Rated Maximum SPL (15W):	120 dB @ 1m
System Input Power Rating:	15W rms long term
Transformer Taps	
70V:	7.5W, 3.75W, 1.87W, 0.94W, OFF, 8Ω
100V:	15W, 7.5W, 3.75W, 1.87W, OFF, 8Ω
Impedance:	667Ω @ 15W, 1.3 kΩ @ 7.5W, 2.7 kΩ @ 3.75W, 5.3 kΩ @ 1.87W, OFF, 8Ω
Water Protection:	IEC529 and IP66 (protected from dust and strong jets of water)

PHYSICAL

Material:	High-impact ABS
Color/Finish:	Light grey (RAL 7035)
Dimensions (Diameter x Length):	8.2 in/208 mm x 10.7 in/272 mm
Net Weight:	4.2 lb/1.9 kg
Mounting:	U-type stainless steel bracket

PH15 FREQUENCY RESPONSE

