



# F1100C-K

## FLOOR DRAIN WITH DOME STRAINER FOR MEMBRANE FLOOR AREAS

Internet address: www.mifab.com

Toll Free: 1-800-465-2736

Canada Toll Free: 1-800-387-3880

**SPECIFICATION:** MIFAB Series F1100C-K-1 lacquered cast iron floor drain with anchor flange, cast iron membrane clamp ring with primary and secondary weepholes for waterproofing membrane, and "K" dome satin finished nickel bronze strainer. (For non-membrane floors, use MIFAB F1100-K Series).

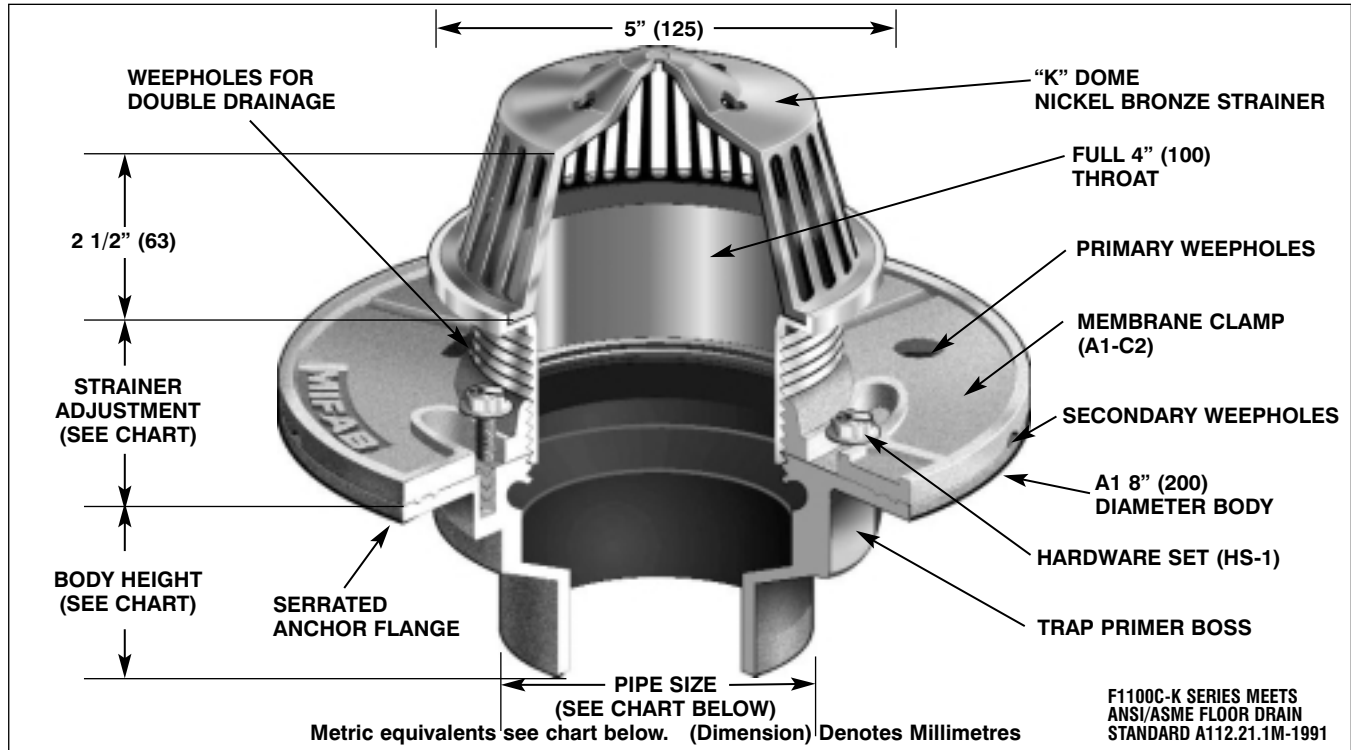

STRAINER DIAMETER	STRAINER ADJUSTMENT		ANSI/ASME RATING	PIPE SIZE	NO HUB	BODY HEIGHT PUSH ON (P)	THREADED (T)	INSIDE CAULK (X)
	MIN	MAX	FREE AREA					
5" (125)	1 9/16" (40)	2 11/16" (65)	15 in <sup>2</sup> (9,677 <sup>2</sup> )	2" (50)	2 3/4" (70)	3 3/8" (86)	2 1/4" (57)	2 3/4" (70)
				3" (75)	2 3/4" (70)	3 3/8" (86)	2 5/8" (67)	2 3/4" (70)
				4" (100)	2 3/4" (70)	3 3/8" (86)	2 5/8" (67)	2 3/4" (70)
				6" (150)	3 1/4" (83)	—	—	—

**OPTIONAL VARIATIONS:**

- Nickel bronze (standard)
  - Stainless steel strainer**
  - 3M epoxy finish
  - Sediment bucket
  - Vandal proof
  - Trap seal primer tapping
  - Backwater valve
  - Acid resistant epoxy coating
  - All galvanized
  - Extension
  - Bronze body
  - Stainless steel body (type 304)
- suffix -1
  - suffix -3
  - suffix -3M
  - suffix -5
  - suffix -6
  - suffix -7
  - suffix -8
  - suffix -11
  - suffix -13
  - suffix -15
  - suffix -27
  - suffix -28
- Stainless steel body (type 316)
  - PVC socket connection body**
  - ABS socket connection body**
  - Closure plug
  - Deck clamp
  - Sump receiver
  - Lacquered cast iron dome
  - Threaded side outlet
  - Clamp ring for low rough-in (min. 1/2" (13))
  - Push on outlet
  - Threaded outlet
  - Inside caulk outlet
  - Elastomeric flange
- suffix -29
  - suffix -30
  - suffix -31
  - suffix -34
  - suffix -40
  - suffix -41
  - suffix -50
  - suffix -90
  - suffix C1
  - suffix P
  - suffix T
  - suffix X
  - suffix -Z

**PARTS:**

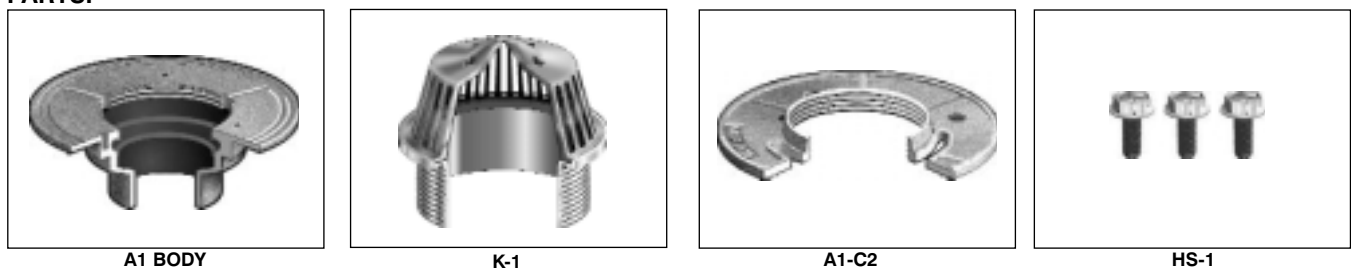

A1 BODY

K-1

A1-C2

HS-1