



F1170C-SD

INTERNATIONAL FLOOR DRAIN WITH INTEGRAL TRAP AND SQUARE SOLID HINGED COVER FOR MEMBRANE FLOOR AREAS

Internet address: www.mifab.com

Toll Free: 1-800-465-2736

Canada Toll Free: 1-800-387-3880

SPECIFICATION: MIFAB Series F1170-SD6-1 lacquered cast iron floor drain with integral trap, 2" (50) cleanout (rodding eye), anchor flange, cast iron membrane clamp ring with primary and secondary weepholes for waterproofing membrane, and adjustable "SD6" square 6" x 6" (150 x 150) nickel bronze strainer with solid hinged cover and secondary grate. (Specify -44-2" (50) no hub or -44-T-1 1/2" (38) female threaded back inlets as shown and required. Maximum three @ 90 degrees. Specify location - A,B, or C).

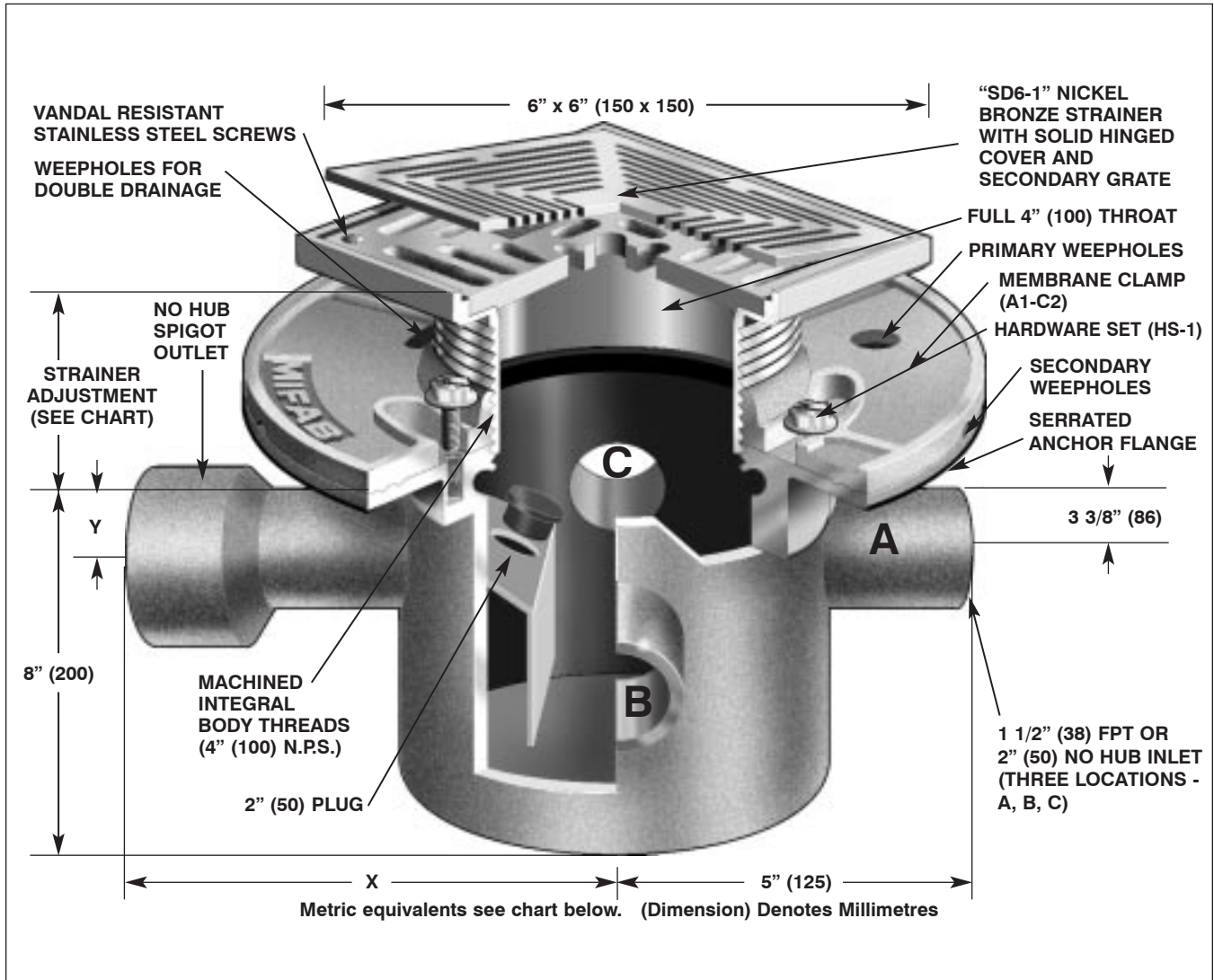

STRAINER SIZE	STRAINER ADJUSTMENT		ANSI/ASME RATING		NO HUB SPIGOT OUTLET SIZE	BODY DIMENSIONS	
	MIN	MAX	FREE AREA	LOAD RATING N.B.(-1)		Y	X
6" x 6" (150 x 150)	2" (50)	3 1/8" (79)	12 in ² (7700 ²)	UP TO 2,000 LBS.	2" (50)	5 3/4" (146)	8 1/2" (210)
					3" (75)	5 3/8" (136)	7 1/4" (184)
					4" (100)	5" (125)	6" (150)

OPTIONAL VARIATIONS:

- | | | | |
|--|------------|--|--------------------|
| <input type="checkbox"/> Nickel bronze | suffix -1 | <input type="checkbox"/> 2" (50) no hub inlet | suffix -44-2" |
| <input type="checkbox"/> Stainless steel strainer | suffix -3 | (specify A,B,C locations) | |
| <input type="checkbox"/> 3M epoxy finish | suffix -3M | <input type="checkbox"/> 1 1/2" (38) female thread inlet | suffix -44T-1 1/2" |
| <input type="checkbox"/> Vandal proof | suffix -6 | (specify A,B,C locations) | |
| <input type="checkbox"/> Trap seal primer tapping | suffix -7 | <input type="checkbox"/> Client logo | suffix -95 |
| <input type="checkbox"/> Acid resistant epoxy coating | suffix -11 | <input type="checkbox"/> Clamp ring for low rough-in (min. 1/2" (13) | suffix C1 |
| <input type="checkbox"/> All galvanized | suffix -13 | <input type="checkbox"/> Vertical outlet | suffix -V |
| <input type="checkbox"/> Extension | suffix -15 | <input type="checkbox"/> Elastomeric flange | suffix -Z |