

Specification: MIFAB® Series F1220-1 lacquered cast iron floor drain with standard satin finished nickel bronze strainer and vandal resistant allen key screws.

Function: Used in showers, kitchens, restrooms, and other non-membrane finished areas. Round, adjustable nickel bronze strainer is used for all types of poured finished floors.

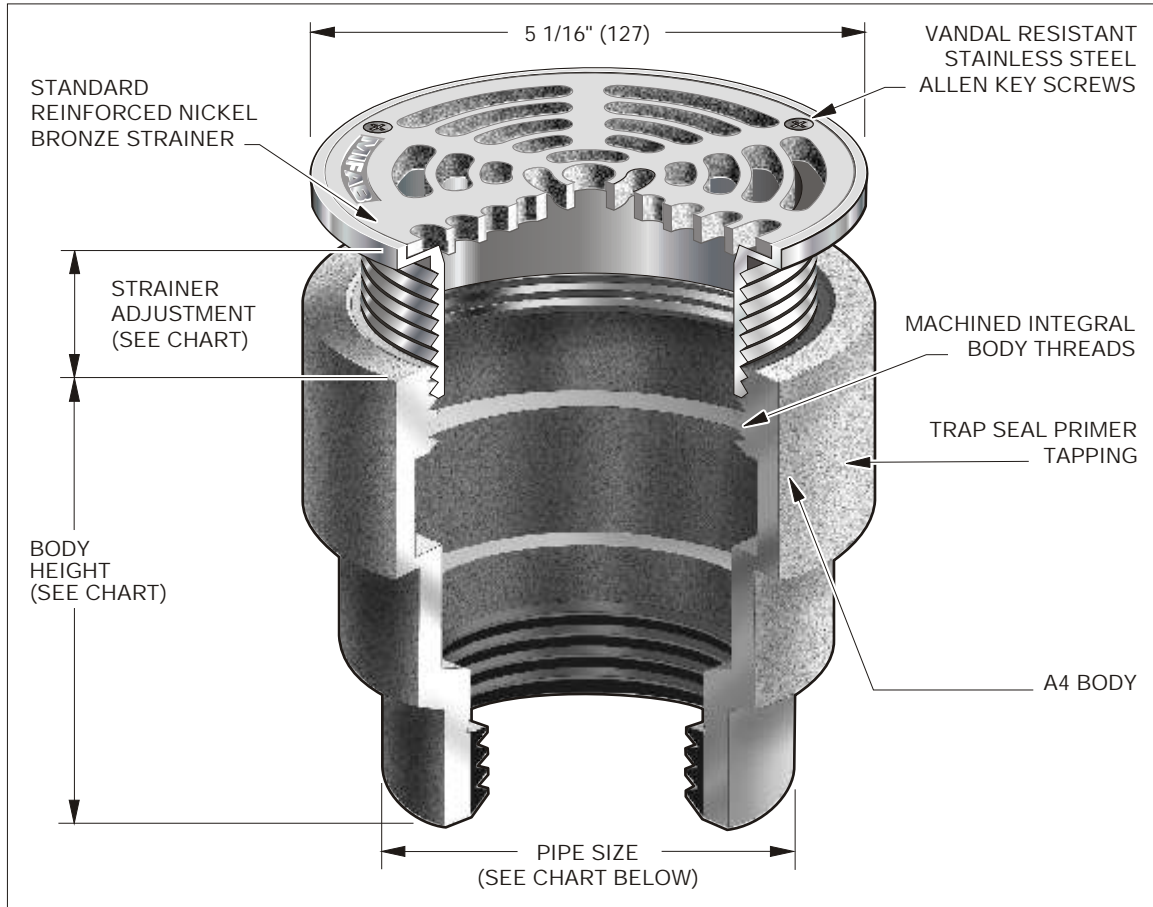

**PARTS:**

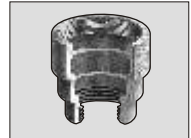

A4 BODY



5-1

F1220 Series meets ANSI/ASME floor drain standard A112.6.3-2001

STRAINER DIAMETER	STRAINER ADJUSTMENT		ANSI/ASME RATING			PIPE SIZE	BODY HEIGHT		
	MIN	MAX	FREE AREA	LOAD RATING LBS.			NO HUB (STANDARD)	PUSH ON (P)	PVC/ABS (-30)/(-31)
5" (127)	3/4" (19)	2 1/16" (52)	8in <sup>2</sup> (5200 <sup>2</sup> )	UP TO 2000 LBS.	5000 TO 7499 LBS.	2" (51)	4" (102)	4 3/8" (111)	4 3/8" (111)
						3" (76)	4" (102)	4 3/8" (111)	4 3/8" (111)
						4" (102)	4" (102)	4 3/8" (111)	4 3/8" (111)

**OPTIONAL VARIATIONS:**

- |   |   |   |
|---|---|---|
| <input type="checkbox"/> Nickel bronze strainer (standard) -1 | <input type="checkbox"/> PVC socket connection body -30                   | <input type="checkbox"/> Oval 4" x 9" funnel -G   |
| <input type="checkbox"/> Polished brass strainer (5" only) -2 | <input type="checkbox"/> ABS socket connection body -31                   | <input type="checkbox"/> 6" x 3" x 1" funnel -J   |
| <input type="checkbox"/> Stainless steel strainer -3          | <input type="checkbox"/> Closure plug -34                                 | <input type="checkbox"/> No hub outlet (standard) |
| <input type="checkbox"/> 3M epoxy finish -3M                  | <input type="checkbox"/> Chrome plated strainer assembly -49              | <input type="checkbox"/> Push on outlet P         |
| <input type="checkbox"/> Ductile iron strainer -4             | <input type="checkbox"/> Lacquered cast iron funnel -50                   |   |
| <input type="checkbox"/> Sediment bucket -5                   | <input type="checkbox"/> Client logo -95                                  |   |
| <input type="checkbox"/> Security screws (T-20 torx & pin) -6 | <input type="checkbox"/> Clamp ring for low rough-in (min. 1/2" (13)) -C1 |   |
| <input type="checkbox"/> Trap seal primer tapping -7          | <input type="checkbox"/> 4" Round funnel -F4                              |   |
| <input type="checkbox"/> Backwater valve -8                   | <input type="checkbox"/> 6" Round funnel -F6                              |   |
| <input type="checkbox"/> Acid resistant epoxy coating -11     |   |   |
| <input type="checkbox"/> All galvanized -13                   |   |   |
| <input type="checkbox"/> Extension -15                        |   |   |

Job Name _____	Page No: _____
Section No: _____	Contractor _____
Schedule No: _____	Purchase Order No: _____