



# F1100-XS

## SQUARE FLOOR DRAIN WITH HEAVY DUTY NICKEL BRONZE STRAINER FOR NON-MEMBRANE FLOOR AREAS

Internet address: www.mifab.com

Toll Free: 1-800-465-2736

Canada Toll Free: 1-800-387-3880

**SPECIFICATION:** MIFAB Series F1100-XS( )-1 lacquered cast iron floor drain with anchor flange, weepholes, and heavy duty, (specify size) square satin finished nickel bronze strainer. (For membrane floors, use MIFAB F1100C-XS Series).

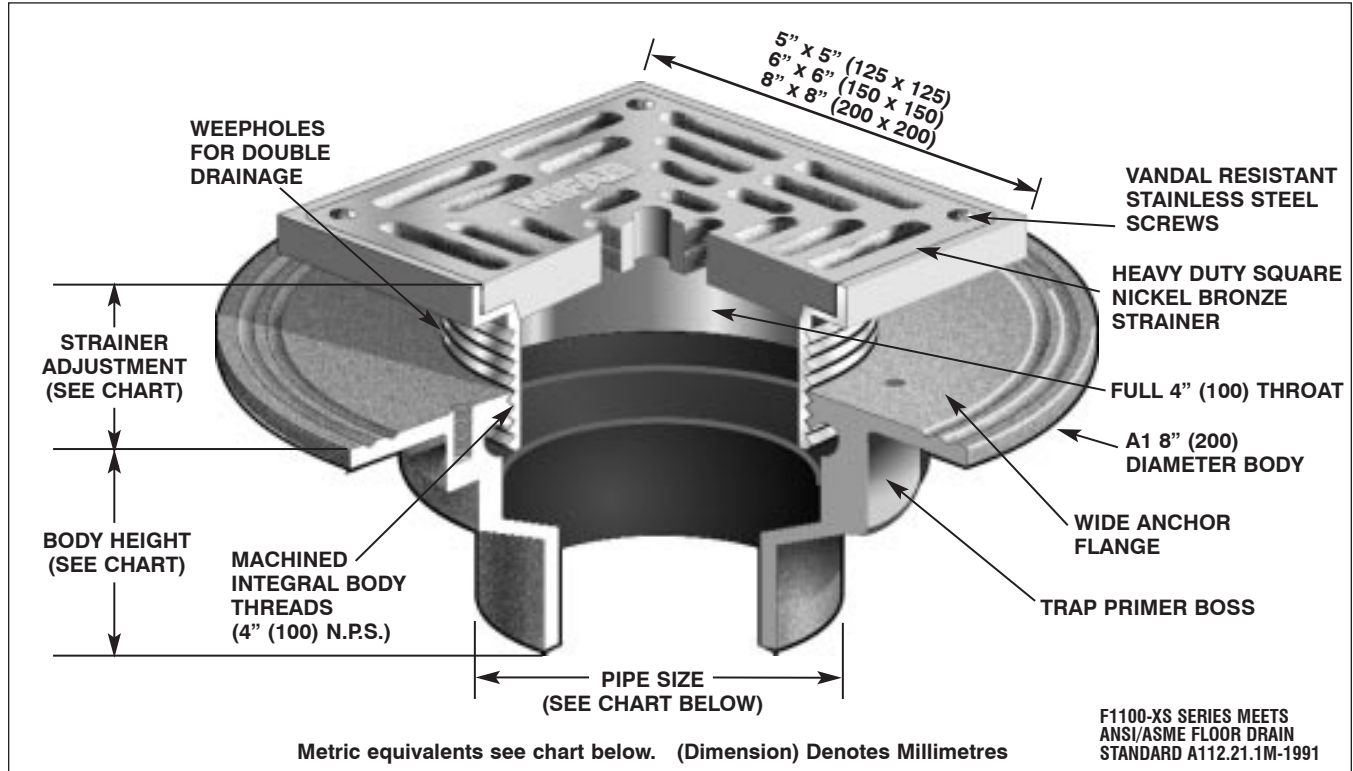

Metric equivalents see chart below. (Dimension) Denotes Millimetres

STRAINER SIZE	STRAINER ADJUSTMENT		ANSI/ASME RATING		PIPE SIZE	NO HUB	BODY HEIGHT		
	MIN	MAX	FREE AREA	LOAD RATING N.B.(-1) D.I.(-4)			PUSH ON (P)	THREADED (T)	INSIDE CAULK (X)
5" x 5" (125 x 125)	5/8" (15)	1 9/16" (40)	9 in <sup>2</sup> (5800 <sup>2</sup> )	UP TO 7,499 LBS. -	2" (50) 3" (75)	2 3/4" (70) 2 3/4" (70)	3 3/8" (86) 3 3/8" (86)	2 1/4" (57) 2 5/8" (67)	2 3/4" (70) 2 3/4" (70)
6" x 6" (150 x 150)	7/8" (22)	1 9/16" (40)	12 in <sup>2</sup> (7700 <sup>2</sup> )	UP TO 7,499 LBS. -	4" (100) 6" (150)	2 3/4" (70) 3 1/4" (83)	3 3/8" (86) —	2 5/8" (67) —	2 3/4" (70) —
8" x 8" (200 x 200)	1 1/4" (32)	2 3/16" (56)	26 in <sup>2</sup> (16800 <sup>2</sup> )	UP TO 7,499 LBS. OVER 10,000 LBS.					

**OPTIONAL VARIATIONS:**

- Nickel bronze (standard)
- Stainless steel strainer
- 3M epoxy finish
- Ductile iron grate (8" x 8" only)
- Sediment bucket
- Vandal proof
- Trap seal primer tapping
- Backwater valve
- Acid resistant epoxy coating

- suffix -1
- suffix -3
- suffix -3M
- suffix -4
- suffix -5
- suffix -6
- suffix -7
- suffix -8
- suffix -11

- All galvanized
- Extension
- Bronze body
- Stainless steel body (type 304)
- Stainless steel body (type 316)
- PVC socket connection body
- ABS socket connection body
- Closure plug
- Deck clamp
- Sump receiver
- Lacquered cast iron funnels
- Threaded side outlet
- Client logo
- 4" Round funnel
- 6" Round funnel
- Oval 4" x 9" funnel
- 6" x 3" x 1" funnel
- Push on outlet
- Threaded outlet
- Inside caulk outlet
- Elastomeric flange

- suffix -13
- suffix -15
- suffix -27
- suffix -28
- suffix -29
- suffix -30
- suffix -31
- suffix -34
- suffix -40
- suffix -41
- suffix -50
- suffix -90
- suffix -95
- suffix -F4
- suffix -F6
- suffix -G
- suffix -J
- suffix P
- suffix T
- suffix X
- suffix -Z

**PARTS:**

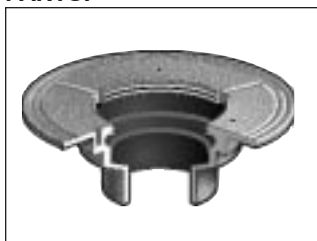

A1 BODY



XS (STRAINER SIZE) -1