



# F1100C-XS

## SQUARE FLOOR DRAIN WITH HEAVY DUTY NICKEL BRONZE STRAINER FOR MEMBRANE FLOOR AREAS

Internet address: [www.mifab.com](http://www.mifab.com)

Toll Free: 1-800-465-2736

Canada Toll Free: 1-800-387-3880

**SPECIFICATION:** MIFAB Series F1100C-XS( )-1 lacquered cast iron floor drain with anchor flange, cast iron membrane clamp ring with primary and secondary weepholes for waterproofing membrane, and standard heavy duty, (specify size), square satin finished nickel bronze strainer. (For non-membrane floors, delete "C" from Series number).

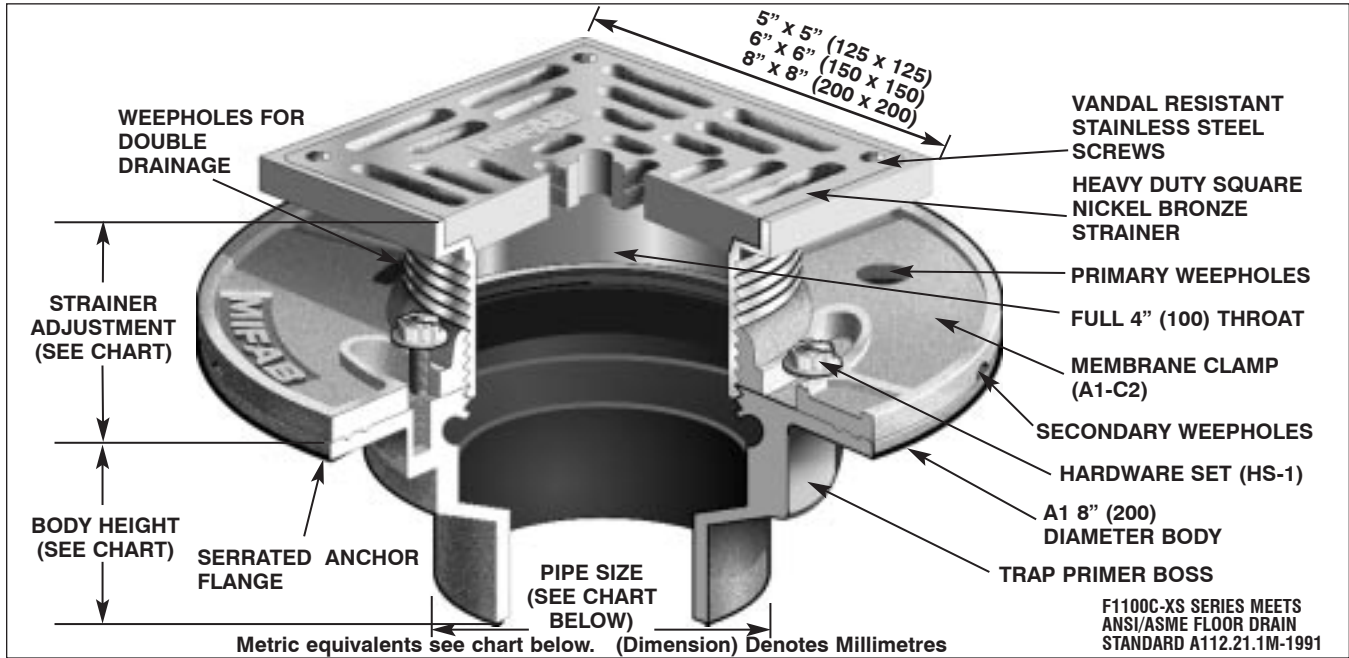

STRAINER SIZE	STRAINER ADJUSTMENT		ANSI/ASME RATING		PIPE SIZE	NO HUB	BODY HEIGHT PUSH ON (P)	THREADED (T)	INSIDE CAULK (X)
	MIN	MAX	FREE AREA	LOAD RATING (N.B.-1) D.I.(-4)					
5" x 5" (125 x 125)	1 3/4" (44)	2 3/4" (70)	9 in <sup>2</sup> (5800 <sup>2</sup> )	UP TO 7,499 LBS. -	2" (50) 3" (75)	2 3/4" (70) 2 3/4" (70)	3 3/8" (86) 3 3/8" (86)	2 1/4" (57) 2 5/8" (67)	2 3/4" (70) 2 3/4" (70)
6" x 6" (150 x 150)	2" (50)	3" (75)	12 in <sup>2</sup> (7700 <sup>2</sup> )	UP TO 7,499 LBS. -	4" (100) 6" (150)	2 3/4" (70) 3 1/4" (83)	3 3/8" (86)	2 5/8" (67)	2 3/4" (70)
8" x 8" (200 x 200)	2 5/8" (67)	3 7/8" (98)	26 in <sup>2</sup> (16800 <sup>2</sup> )	UP TO 7,499 LBS. OVER 10,000 LBS.					

**OPTIONAL VARIATIONS:**

- Nickel bronze (standard)
- Stainless steel strainer**
- 3M epoxy finish
- Ductile iron grate (8" x 8" only)
- Sediment bucket
- Vandal proof
- Trap seal primer tapping
- Backwater valve
- Acid resistant epoxy coating
- All galvanized
- Extension
- Bronze body
- Stainless steel body (type 304)
- Stainless steel body (type 316)
- PVC socket connection body**

- suffix -1
- suffix -3**
- suffix -3M
- suffix -4
- suffix -5
- suffix -6
- suffix -7
- suffix -8
- suffix -11
- suffix -13
- suffix -15
- suffix -27
- suffix -28
- suffix -29
- suffix -30**

**ABS socket connection body**

- Closure plug
- Deck clamp
- Sump receiver
- Lacquered cast iron funnels
- Threaded side outlet
- Client logo
- Membrane clamp for low rough-in (min. 5/8" (15))
- 4" Round funnel
- 6" Round funnel
- Oval 4" x 9" funnel
- 6" x 3" x 1" funnel
- Push on outlet
- Threaded outlet
- Inside caulk outlet
- Elastomeric flange

**suffix -31**

- suffix -34
- suffix -40
- suffix -41
- suffix -50
- suffix -90
- suffix -95
- suffix C1
- suffix -F4
- suffix -F6
- suffix -G
- suffix -J
- suffix P
- suffix T
- suffix X
- suffix -Z

**PARTS:**



A1 BODY



XS (STRAINER SIZE) -1



A1-C2



HS-1