



F1140C

FLOOR DRAIN WITH ROUND TRACTOR GRATE, INTEGRAL DEEP SEAL TRAP AND CLEANOUT

Internet address: www.mifab.com

Toll Free: 1-800-465-2736

Canada Toll Free: 1-800-387-3880

SPECIFICATION: MIFAB Series F1140C lacquered cast iron floor drain with anchor flange, cast iron clamp ring with primary and secondary weepholes for waterproofing membrane, seepage collection sump, integral deep seal trap and standard 1" (25) thick, 7" (175) round (specify F1140C-7) or 9" (230) round (specify F1140C-9), ductile iron tractor grate and standard reinforced 5" (125) diameter ductile iron floor cleanout with access cover, "O" ring Test Seal and plug with primary gasket seal.

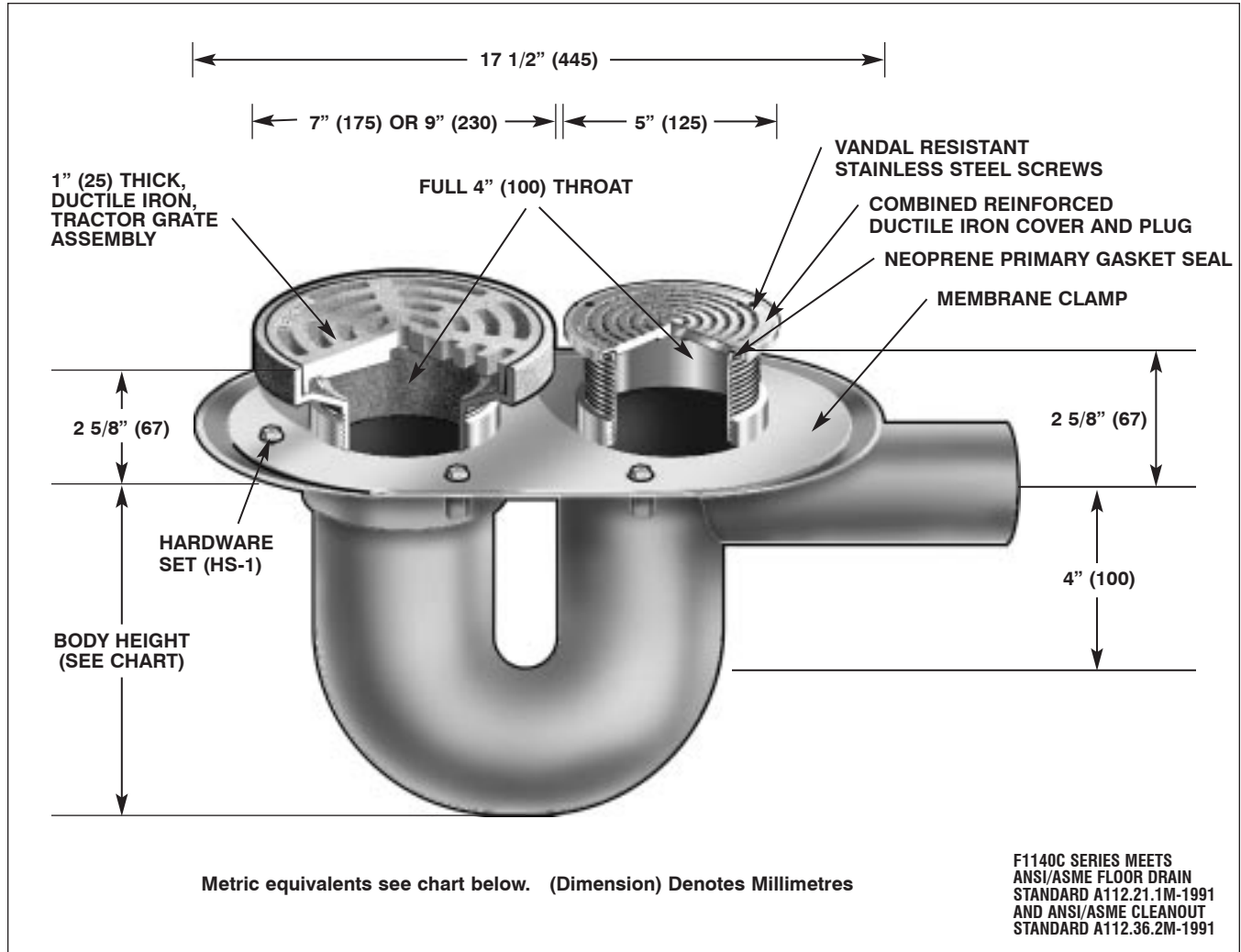

MODEL NUMBER	STRAINER DIAMETER	ANSI/ASME RATING		LOAD RATING D.I. (-4)	BODY HEIGHT	
		FREE AREA	LOAD RATING		PIPE SIZE	NO HUB
F1140C-7	7" (175)	11 in ² (7,096 ^{cm2})	ANSI/ASME	UP TO	2" (50)	13 1/2" (345)
F1140C-9	9" (230)	18 in ² (11,600 ^{cm2})	LOAD CLASS "SPECIAL DUTY" (OVER 10,000 LBS.)	7,499 LBS.	3" (75) 4" (100)	13 1/2" (345) 13 1/2" (345)

OPTIONAL VARIATIONS:

- | | | | |
|---|------------------|--|------------|
| <input type="checkbox"/> Nickel bronze | suffix -1 | <input type="checkbox"/> Extension | suffix -15 |
| <input type="checkbox"/> 3M epoxy finish | suffix -3M | <input type="checkbox"/> Square top | suffix -16 |
| <input type="checkbox"/> Stainless steel strainer (veneer) and cover | suffix -3 | <input type="checkbox"/> ABS plug with neoprene gasket (cleanout only) | suffix -34 |
| <input type="checkbox"/> Ductile iron grate and cleanout (standard) | suffix -4 | <input type="checkbox"/> Lacquered cast iron funnels | suffix -50 |
| <input type="checkbox"/> Sediment bucket | suffix -5 | <input type="checkbox"/> Client logo | suffix -95 |
| <input type="checkbox"/> Vandal proof | suffix -6 | <input type="checkbox"/> 4" Round funnel | suffix -F4 |
| <input type="checkbox"/> Trap seal primer tapping | suffix -7 | <input type="checkbox"/> 6" Round funnel | suffix -F6 |
| <input type="checkbox"/> Backwater valve | suffix -8 | <input type="checkbox"/> Oval 4" x 9" funnel | suffix -G |
| <input type="checkbox"/> Acid resistant epoxy coating | suffix -11 | <input type="checkbox"/> 6" x 3" x 1" funnel | suffix -J |
| <input type="checkbox"/> Galvanized top assembly | suffix -12 | <input type="checkbox"/> Elastomeric flange | suffix -Z |
| <input type="checkbox"/> All galvanized | suffix -13 | | |