

Specification: MIFAB® Series F1650 flushing rim floor drain with white epoxy coated interior and exterior cast iron body, 3/4" (19)N.P.T. flushing connection, anchor flange, membrane clamp, and stain finished nickel bronze grate and frame with stainless steel allen key vandal proof screws.

Function: Used in hospital operating and veterinary rooms, industrial and educational laboratories where waste must be drained to the sewer. Appropriate for mental institutions, zoos and prisons as drain type water closets.

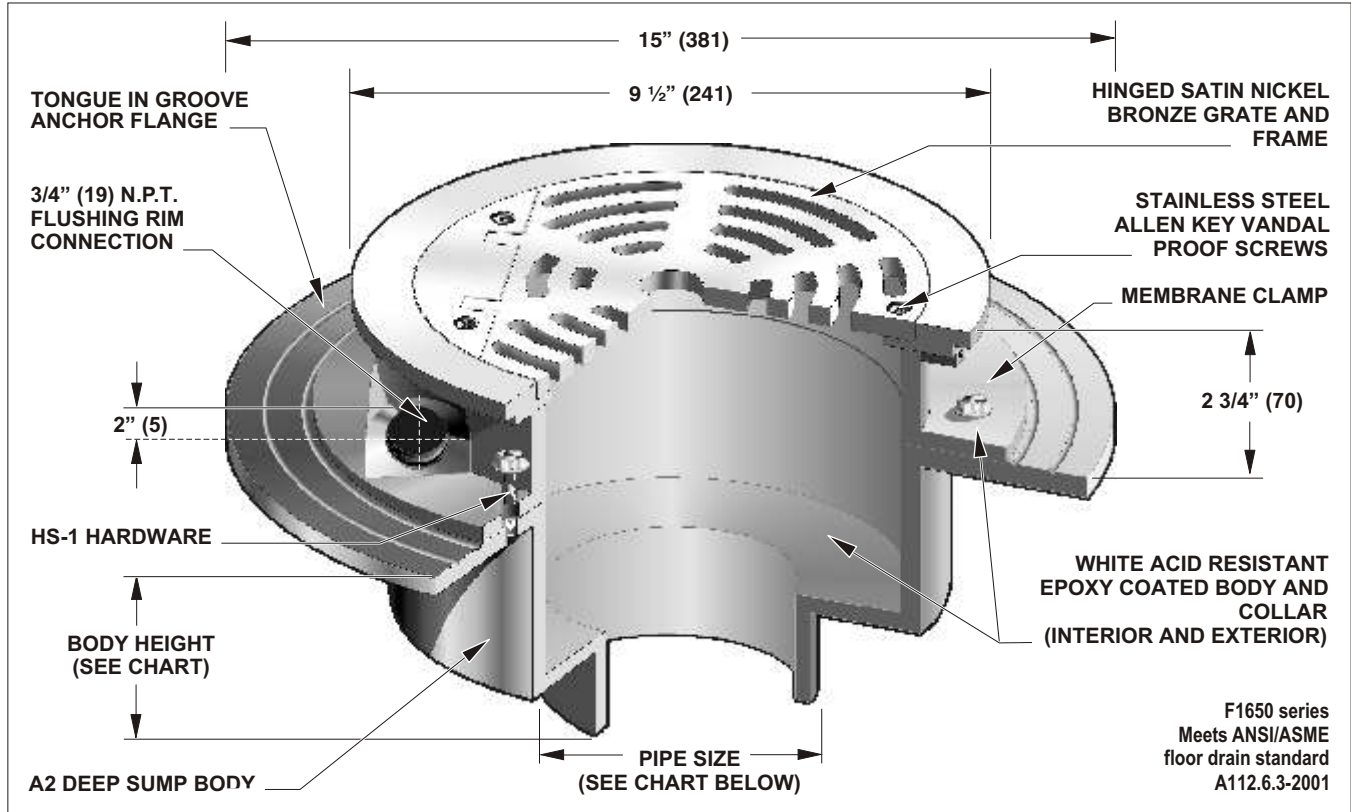

Note: See F1670 for water supply control box to be used with the flushing rim floor drain. Use a vacuum breaker between the potable water supply and the connection to the flushing rim connection (by others).

STRAINER DIAMETER	ANSI/ASME RATING			PIPE SIZE	BODY HEIGHT				
	FREE AREA	LOAD RATING			NO HUB (STANDARD)	PUSH ON (P)	THREADED (T)	INSIDE CAULK (X)	PVC/ABS (-30)/(-31)
		N.B. (-1)	SS. (-3)						
9" (229)	18 in ² (11,613 ³)	UP TO 2000 LBS.	2,000	2" (51)	5 7/16" (138)	6 1/8" (156)	5 7/16" (138)	6 1/4" (159)	7 1/8" (181)
			TO 4,999 LBS.	3" (76)	5 7/16" (138)	6 1/8" (156)	5 7/16" (138)	6 1/4" (159)	8 1/8" (206)
			4" (102)	5 7/16" (138)	6 1/8" (156)	5 7/16" (138)	6 1/4" (159)	8 1/8" (206)	
			5" (127)	5 7/16" (138)	-	5 7/16" (138)	6 1/4" (159)	-	
			6" (152)	5 7/8" (149)	8" (203)	6" (152)	6 1/4" (159)	-	
			8" (203)	5 7/8" (149)	-	-	5 5/8" (143)	-	

OPTIONAL VARIATIONS:

- | | | | | | | | | |
|---|---------------|------------|--|---------------|-----|---|---------------|--------|
| <input type="checkbox"/> Nickel bronze frame and grate | SUFFIX | (Standard) | <input type="checkbox"/> Bronze body | SUFFIX | -27 | <input type="checkbox"/> No hub side outlet | SUFFIX | - 90NH |
| <input type="checkbox"/> Stainless steel frame and grate | -3 | | <input type="checkbox"/> Stainless steel body (type 304) | -28 | | <input type="checkbox"/> Client logo | -95 | |
| <input type="checkbox"/> 3M epoxy finish | -3M | | <input type="checkbox"/> Stainless steel body (type 316) | -29 | | <input type="checkbox"/> No hub outlet | (Standard) | |
| <input type="checkbox"/> Sediment bucket | -5 | | <input type="checkbox"/> PVC socket connection body | -30 | | <input type="checkbox"/> Loose set grate | -A | |
| <input type="checkbox"/> Vandal proof secured grate | -6 | | <input type="checkbox"/> ABS socket connection body | -31 | | <input type="checkbox"/> Push on outlet | P | |
| <input type="checkbox"/> All galvanized | -13 | | <input type="checkbox"/> Closure plug | -34 | | <input type="checkbox"/> Threaded outlet | T | |
| <input type="checkbox"/> Secondary flat strainer | -21 | | <input type="checkbox"/> Underdeck clamp | -40 | | <input type="checkbox"/> Inside caulk outlet | X | |
| <input type="checkbox"/> Nickel bronze hinged solid cover | -25-1 | | <input type="checkbox"/> Sump receiver | -41 | | <input type="checkbox"/> Extended wide elastomeric flange | -Z | |
| | | | <input type="checkbox"/> Threaded side outlet | - 90 | | | | |

Job Name: _____	Page No: _____
Section No: _____	Contractor: _____
Schedule No: _____	Purchase Order No: _____