



F1100C-90

FLOOR DRAIN WITH SIDE OUTLET FOR MEMBRANE FLOOR AREAS

Internet address: www.mifab.com

Toll Free: 1-800-465-2736

Canada Toll Free: 1-800-387-3880

SPECIFICATION: MIFAB Series F1100C-90-(-)-1 lacquered cast iron floor drain with threaded side outlet, anchor flange, cast iron membrane clamp ring with primary and secondary weepholes for waterproofing membrane, and standard reinforced (specify diameter), satin finished nickel bronze strainer. (For non-membrane floors, use MIFAB F1100-90 Series).

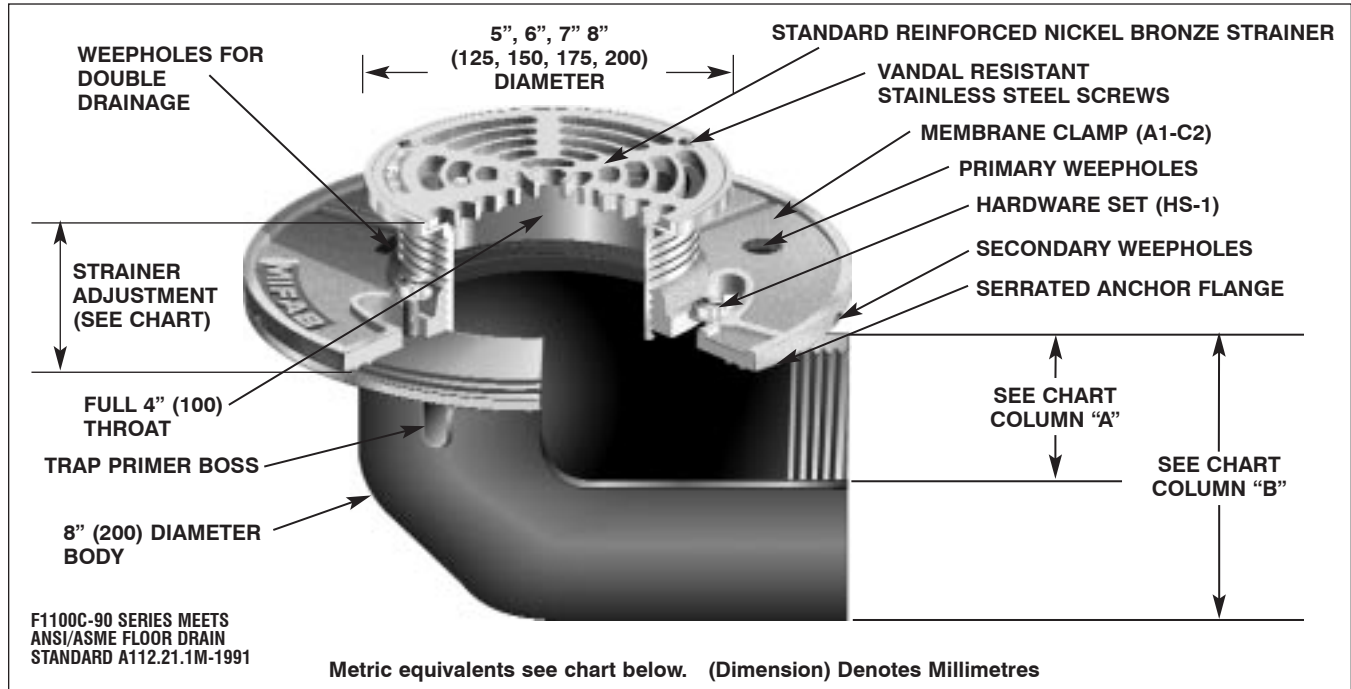

STRAINER DIAMETER	STRAINER ADJUSTMENT		ANSI/ASME RATING		PIPE SIZE	BODY HEIGHT	
	MIN	MAX	FREE AREA	LOAD RATING N.B. (-1) D.I. (-4)		A	B
5" (125)	1 9/16" (40)	2 11/16" (68)	8 in ² (5200 ²)	UP TO 2,000 LBS. UP TO 7,499 LBS.	2" (50) 3" (75)	2 1/2" (63) 3 1/2" (89)	4 3/8" (111) 4 3/8" (111)
6" (150)	1 11/16" (43)	2 5/8" (67)	9 in ² (5800 ²)	UP TO 2,000 LBS. —			
7" (175)	1 1/2" (38)	2 5/8" (67)	12 in ² (7700 ²)	UP TO 2,000 LBS. —			
8" (200)	1 7/8" (48)	2 3/4" (70)	18 in ² (11600 ²)	UP TO 2,000 LBS. OVER 10,000 LBS.			

OPTIONAL VARIATIONS:

- Nickel bronze (standard)
- Stainless steel strainer**
- 3M epoxy finish
- Ductile iron grate (5", 8" only)
- Sediment bucket
- Vandal proof
- Trap seal primer tapping
- Backwater valve
- Acid resistant epoxy coating
- All galvanized

- suffix -1
- suffix -3
- suffix -3M
- suffix -4
- suffix -5
- suffix -6
- suffix -7
- suffix -8
- suffix -11
- suffix -13

- Extension
- Closure plug
- Lacquered cast iron funnels
- Client logo
- Clamp ring for low rough-in (min. 1/2" (13))
- 4" Round funnel
- 6" Round funnel
- Oval 4" x 9" funnel
- 6" x 3" x 1" funnel
- No hub side outlet
- Elastomeric flange

- suffix -15
- suffix -34
- suffix -50
- suffix -95
- suffix C1
- suffix -F4
- suffix -F6
- suffix -G
- suffix -J
- suffix NH
- suffix -Z

PARTS:



A1-90



STANDARD (STRAINER SIZE) -1



A1-C2

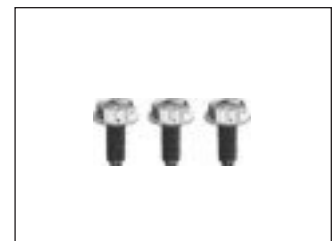

HS-1