



F1330C

FLOOR DRAIN WITH 9" ROUND TRACTOR GRATE AND DEEP SUMP

Internet address: www.mifab.com

Toll Free: 1-800-465-2736

Canada Toll Free: 1-800-387-3880

SPECIFICATION: MIFAB Series F1330C-4 lacquered cast iron floor drain with anchor flange, cast iron clamp ring with primary and secondary weepholes for waterproofing membrane, adjustable collar with deep sump body, and standard 1" (25) thick, 9" (230) round, ductile iron tractor grate.

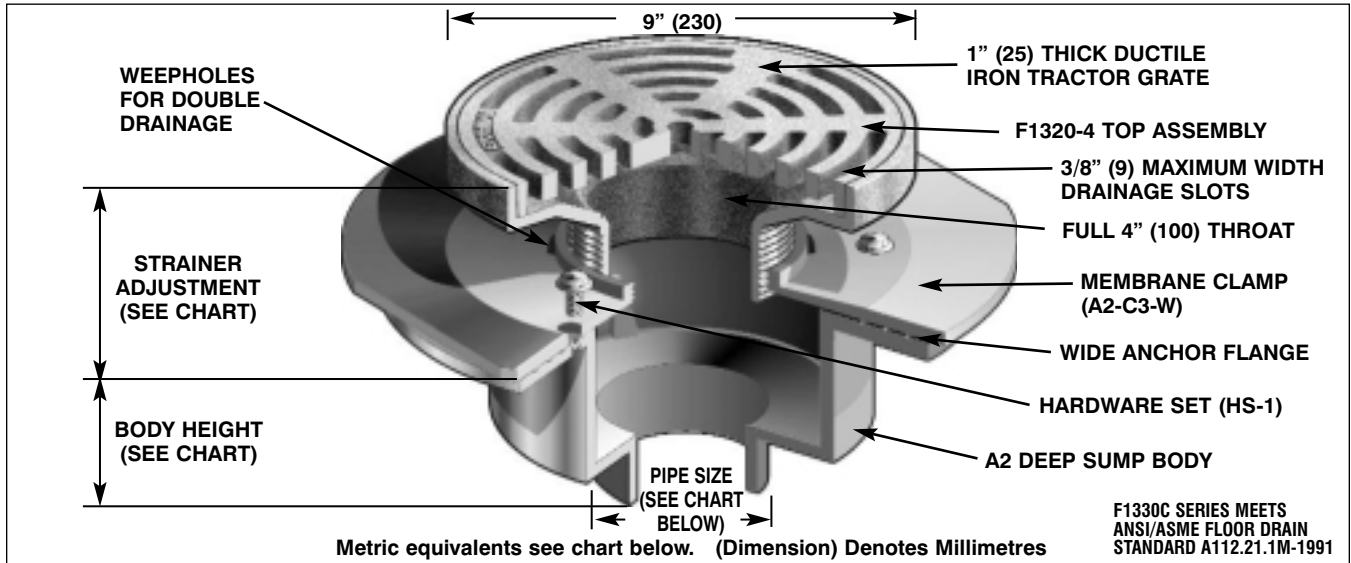

STRAINER DIAMETER	STRAINER ADJUSTMENT		ANSI/ASME RATING		PIPE SIZE	BODY HEIGHT NO HUB	PUSH ON (P)
	MIN	MAX	FREE AREA	LOAD RATING			
9" (230)	2" (50)	2 7/8 (73)	18 in ² (11,613 ²)	ANSI/ASME	2" (50)	5 7/16" (138)	6 1/8" (156)
				LOAD CLASS	3" (75)	5 7/16" (138)	6 1/8" (156)
				"SPECIAL DUTY"	4" (100)	5 7/16" (138)	6 1/8" (156)
				(OVER 10,000 LBS.)	6" (150)	5 7/8" (149)	—

OPTIONAL VARIATIONS:

- Nickel bronze (vener)
- Stainless steel (vener)**
- 3M epoxy finish
- Ductile iron grate (standard)
- Sediment bucket
- Vandal proof
- Trap seal primer tapping
- Backwater valve
- Acid resistant epoxy coating
- Galvanized grate and frame
- All galvanized
- Non tilt grate
- Extension
- Square top
- Dome grate
- Secondary dome
- Secondary strainer
- Chained grate
- Solid secured cover

- suffix -1
- suffix -3**
- suffix -3M
- suffix -4
- suffix -5
- suffix -6
- suffix -7
- suffix -8
- suffix -11
- suffix -12
- suffix -13
- suffix -14
- suffix -15
- suffix -16
- suffix -18
- suffix -20
- suffix -21
- suffix -23
- suffix -24

- Bronze body
- Stainless steel body (type 304)
- Stainless steel body (type 316)
- PVC socket connection body**
- ABS socket connection body**
- Less flange
- Closure plug
- Bronze mesh bucket
- Deck clamp
- Sump receiver
- Lacquered cast iron funnels
- Threaded side outlet
- Client logo
- Round 4" funnel
- Round 6" funnel
- Oval 4" x 9" funnel
- 6" x 3" x 1" funnel
- Push on outlet
- Threaded outlet
- Inside caulk outlet
- Elastomeric flange

- suffix -27
- suffix -28
- suffix -29
- suffix -30**
- suffix -31**
- suffix -33
- suffix -34
- suffix -35
- suffix -40
- suffix -41
- suffix -50
- suffix -90
- suffix -95
- suffix -F4
- suffix -F6
- suffix -G
- suffix -J
- suffix P
- suffix T
- suffix X
- suffix -Z

PARTS:



A2 BODY



F1320-4



A2-C3-W

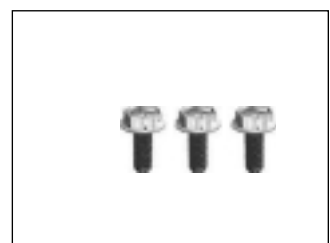

HS-1