

**Specification:** MIFAB® Series F1160 Prison Cell floor drain with lacquered cast iron body and anchor flange, weepholes, 3" no hub side outlet, integral deep seal trap with cleanout plug and adjustable nickel bronze strainer with T-20 torx and pin security screws. (For membrane floors, add Suffix -C for the membrane clamp).

**Function:** Used in prisons, detention and any other areas that require a drain with security screws to prevent access and tampering. Side outlet with integral deep seal trap permits easy installation in areas with limited installation space.

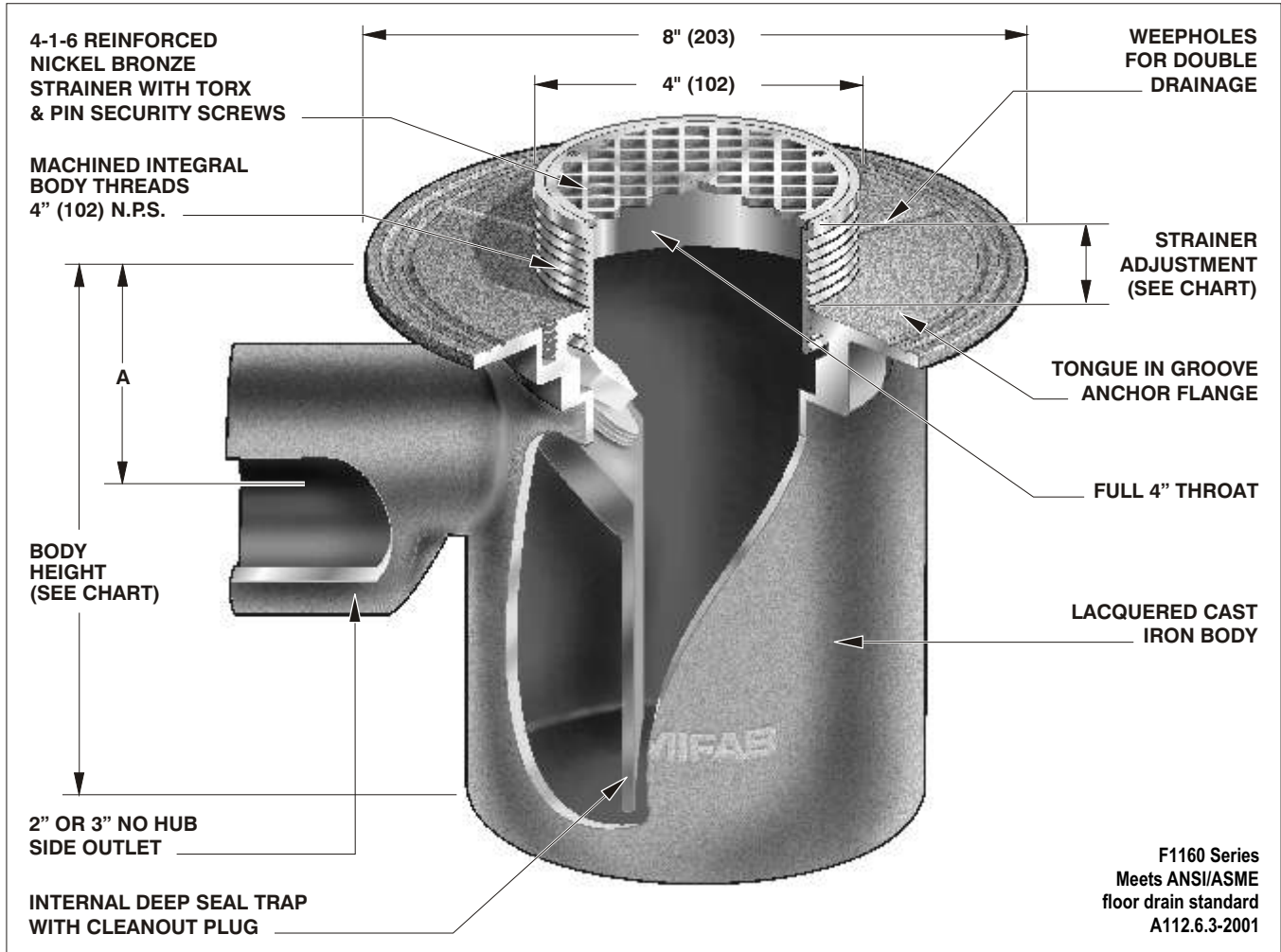

F1160 Series  
Meets ANSI/ASME  
floor drain standard  
A112.6.3-2001

STRAINER DIAMETER	STRAINER ADJUSTMENT		ANSI/ASME RATING		PIPE SIZE	BODY HEIGHT	
	MIN	MAX	FREE AREA	LOAD RATING (-1) N.B.		NO HUB (STANDARD)	"A"
4" (102)	1/2" (13)	1 1/2" (38)	3 1/2in <sup>2</sup>	UP TO 2000 LBS.	2" (51) 3" (76)	7 7/8" (200) 7 7/8" (200)	3 3/4" (95) 3 3/4" (95)

**OPTIONAL VARIATIONS:**

- Nickel bronze strainer
- 3M epoxy finish
- Sediment bucket
- Security screws (T-20 torx and pin)
- Trap seal primer connection
- Backwater valve
- Acid resistant epoxy coating
- All galvanized
- Extension

**SUFFIX**

- (Standard)
- 3M
- (Standard)
- 5
- 7
- 8
- 11
- 13
- 15

**SUFFIX**

- Stainless steel body (Type 304) -28
- Stainless steel body (Type 316) -29
- Chrome plated strainer -49
- Client logo -95
- (Standard)
- No hub outlet (Standard)
- Membrane clamp -C
- Membrane clamp for low rough-in (min. 7/8" (22)) -C1
- Threaded outlet T
- Extended wide elastomeric flange -Z

Job Name: \_\_\_\_\_ Page No: \_\_\_\_\_  
 Section No: \_\_\_\_\_ Contractor: \_\_\_\_\_  
 Schedule No: \_\_\_\_\_ Purchase Order No: \_\_\_\_\_