



F1100C-X

FLOOR DRAIN WITH NICKEL BRONZE HEAVY DUTY STRAINER FOR MEMBRANE FLOOR AREAS

Internet address: www.mifab.com

Toll Free: 1-800-465-2736

Canada Toll Free: 1-800-387-3880

SPECIFICATION: MIFAB Series F1100C-X()-1 lacquered cast iron floor drain with anchor flange, cast iron membrane clamp ring with primary and secondary weepholes for water proofing membrane, and standard heavy duty, (specify diameter), satin finished nickel bronze strainer. (For non-membrane floors, delete "C" from Series number).

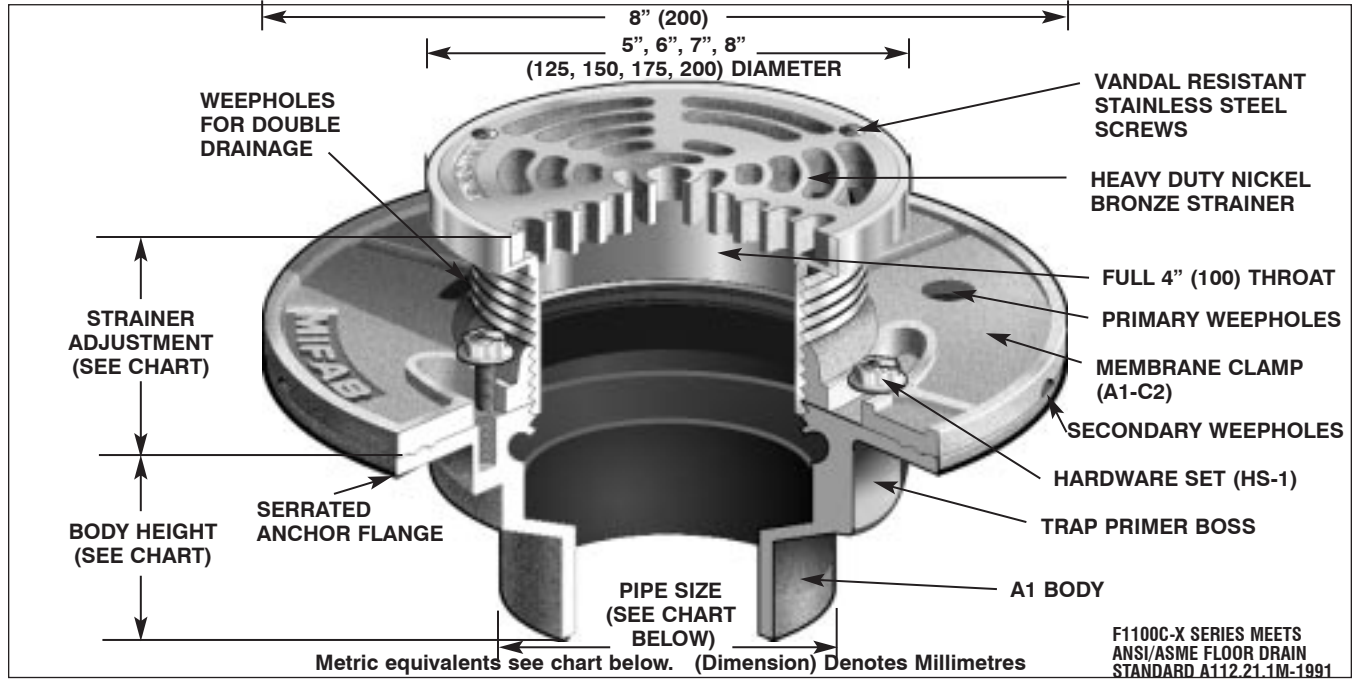

Metric equivalents see chart below. (Dimension) Denotes Millimetres

F1100C-X SERIES MEETS ANSI/ASME FLOOR DRAIN STANDARD A112.21.1M-1991

STRAINER DIAMETER	STRAINER ADJUSTMENT		ANSI/ASME RATING		PIPE SIZE	NO HUB	BODY HEIGHT		
	MIN	MAX	FREE AREA	LOAD RATING N.B. (-1) D.I. (-4)			PUSH ON (P)	THREADED (T)	INSIDE CAULK (X)
5" (125)	1 9/16" (40)	2 11/16" (68)	8 in ² (5200 ²)	UP TO 7,499 LBS. UP TO 7,499 LBS.	2" (50) 3" (75)	2 3/4" (70) 2 3/4" (70)	3 3/8" (86) 3 3/8" (86)	2 1/4" (57) 2 5/8" (67)	2 3/4" (70) 2 3/4" (70)
6" (150)	1 11/16" (43)	2 5/8" (67)	9 in ² (5800 ²)	UP TO 7,499 LBS. —	4" (100)	2 3/4" (70)	3 3/8" (86)	2 5/8" (67)	2 3/4" (70)
7" (175)	1 1/2" (38)	2 5/8" (67)	12 in ² (7700 ²)	UP TO 7,499 LBS. —	6" (150)	3 1/4" (83)	—	—	—
8" (200)	1 7/8" (48)	2 3/4" (70)	18 in ² (11600 ²)	UP TO 7,499 LBS. OVER 10,000 LBS.					

OPTIONAL VARIATIONS:

- Nickel bronze (standard)
- Stainless steel strainer**
- 3M epoxy finish
- Ductile iron grate (5", 8" only)
- Sediment bucket
- Vandal proof
- Trap seal primer tapping
- Backwater valve
- Acid resistant epoxy coating
- All galvanized
- Extension
- Bronze body
- Stainless steel body (type 304)
- Stainless steel body (type 316)
- PVC socket connection body**

- suffix -1
- suffix -3**
- suffix -3M
- suffix -4
- suffix -5
- suffix -6
- suffix -7
- suffix -8
- suffix -11
- suffix -13
- suffix -15
- suffix -27
- suffix -28
- suffix -29
- suffix -30**

ABS socket connection body

- Closure plug
- Deck clamp
- Sump receiver
- Lacquered cast iron funnels
- Threaded side outlet
- Client logo
- Membrane clamp for low rough-in (min. 1/2" (13))
- 4" Round funnel
- 6" Round funnel
- Oval 4" x 9" funnel
- 6" x 3" x 1" funnel
- Push on outlet
- Threaded outlet
- Inside caulk outlet
- Elastomeric flange

- suffix -31**
- suffix -34
- suffix -40
- suffix -41
- suffix -50
- suffix -90
- suffix -95
- suffix C1
- suffix -F4
- suffix -F6
- suffix -G
- suffix -J
- suffix P
- suffix T
- suffix X
- suffix -Z

PARTS:



A1 BODY



X (STRAINER SIZE) -1



A1-C2



HS-1